

CHARACTERISTICS

Mini electric cylinder MCE is a mini linear drive with a piston rod. By using an integrated precision ball screw drive, the rotary motion (rotation) of the drive shaft is converted to the linear motion (translation) of the piston rod with high mechanical efficiency and low internal friction.

High-performance features such as high speed, good positioning accuracy, and high repeatability are ensured through a precision ball screw drive and an anti-rotating piston rod device.

A preassembled standard motor (in-line with a motor adapter and a coupling or in-parallel with a motor side drive and a timing belt) together with the standard drive, makes the system plug and play ready. Compact dimensions and optimally selected motor combinations cover a wide range of applications.

The aluminium cylinder profile includes T-slots on the bottom for fixing the electric cylinder, as well as side slots for clamping fixtures and magnetic field sensors.

Options, such as female piston rod end and extended piston rod, together with a wide range of accessories make this product highly flexible. There is also an option of the mini electric cylinder without the preassembled motor if an individual motor is required.

For applications, where higher resistance to lateral loads or torsional moments is required, a guiding unit GUC can be used. By using the guiding unit, which offers high precision guiding and positioning, the mini electric cylinders can easily be combined to the multi-axis systems.

Excellent price-performance ratio and a quick delivery time, due to standard lengths, are ensured.

Each MCE is optimally pre-lubricated and ready for a maintenance-free operating process. MCE allows relatively high load capacities and optimal cycles for moving the larger payloads at high speeds in both horizontal and vertical directions.

i The aluminium profiles are manufactured according to the medium EN 12020-2 standard

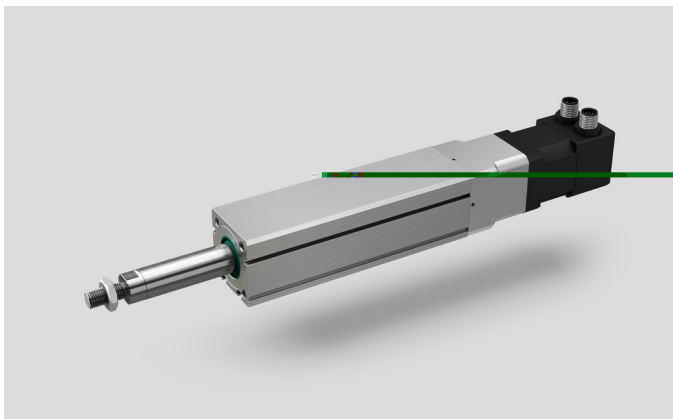

Motor adapter VK with a coupling and a motor

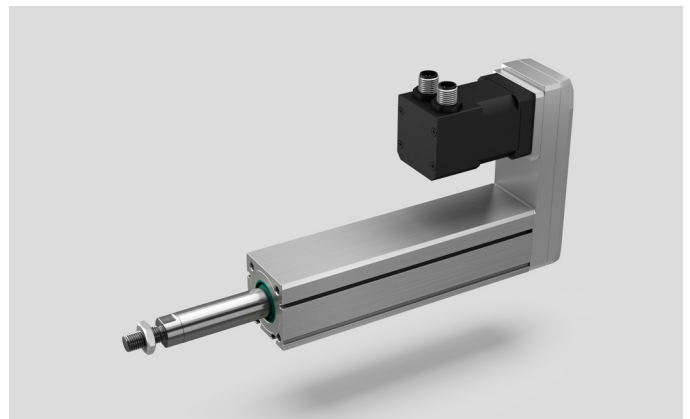

Motor side drive with timing a belt and a motor

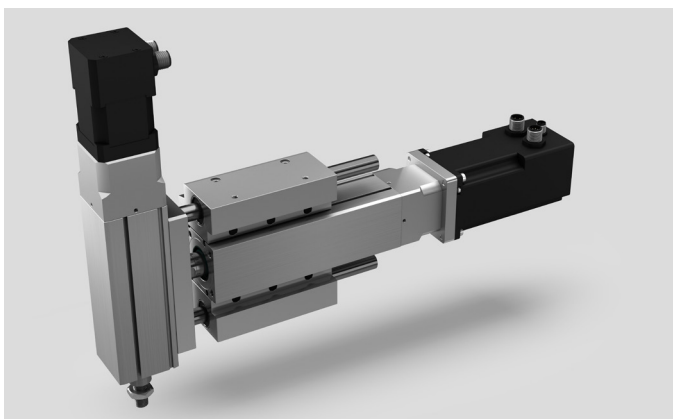

Multi-axis system (guiding unit GUC is used)

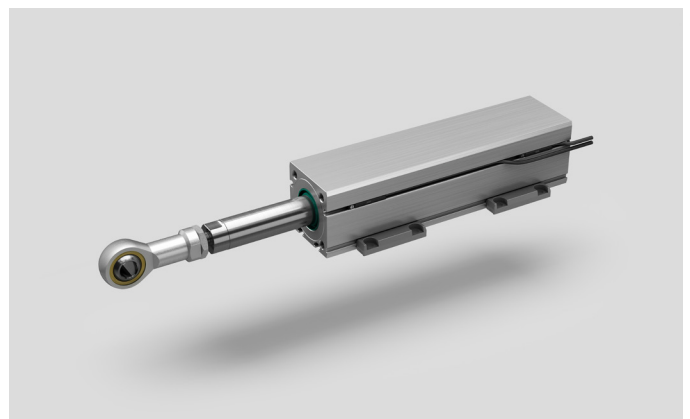

Accessories, MCE without a preassembled motor

STRUCTURAL DESIGN

Combination with a standard motor and a motor adapter VK

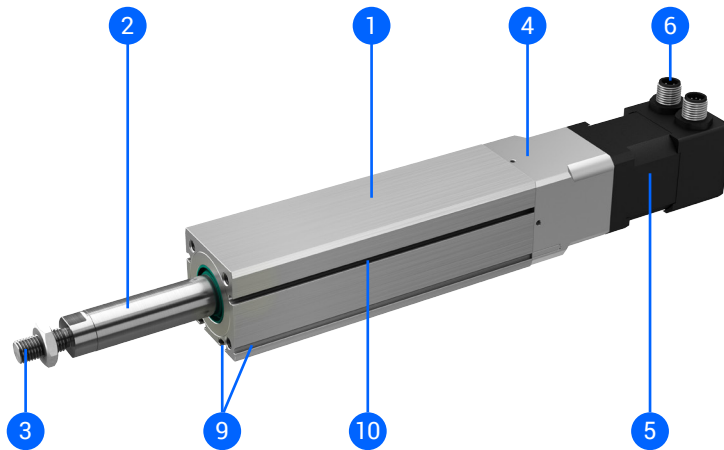

- 1 – Compact aluminium cylinder profile
- 2 – Piston rod (stainless steel) with an anti-rotation device
- 3 – Piston rod end (optionally a female thread is available)
- 4 – Motor adapter VK with a coupling
- 5 – Preassembled motor (with/without brake)
- 6 – Standard connectors (motor, encoder and brake – optionally)
- 7 – Motor side drive with a timing belt
- 8 – Drive shaft of a precision ball screw drive
- 9 – Slots for mounting
- 10 – Slots for the magnetic field sensors (size 32 and 45) or mounting the sensor holder (size 25)

Combination with a standard motor and a motor side drive MSD

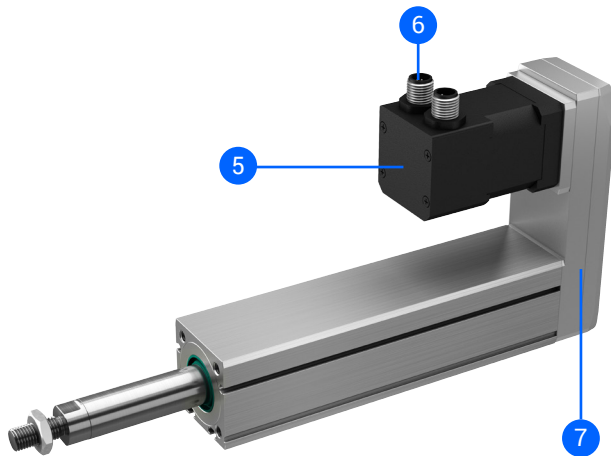

Without a motor

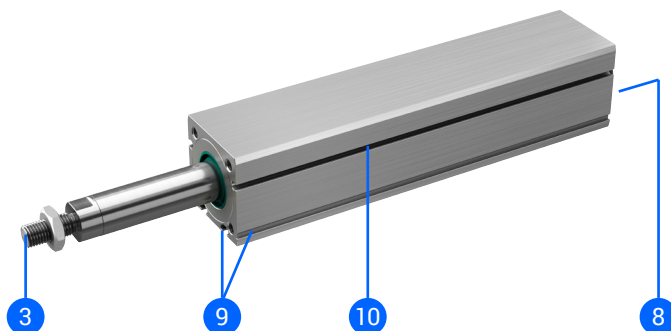

HOW TO ORDER

MCE -
 45 -
 1003 -
 150 -
 F -
 E20 -
 0 -
 AB -
 AU -
 AA -
 AB -
 AA

Series: MCE

Size:
 - 25
 - 32
 - 45

Ball screw size:
 - MCE 25: $\varnothing 6 \times 2, \varnothing 6 \times 6$
 - MCE 32: $\varnothing 8 \times 2, \varnothing 8 \times 8$
 - MCE 45: $\varnothing 10 \times 3, \varnothing 10 \times 10$

Absolute stroke [mm]:
 (Absolute stroke = Effective stroke + 2 × Safety stroke)
 - 25, 50, 75, 100, 125, 150, 175, 200

Option 1:
 - Leave blank: Standard (male thread)
 - F: Female thread

Option 2:
 - Leave blank: Without
 - Extended piston rod E [mm]
 (Max. extended piston rod: $E_{max} = 100$ mm)

Guiding unit:
 - 0: Without a guiding unit
 - B: With a guiding unit GUC (ball bushes)

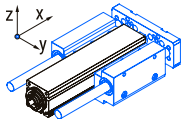

i Guiding unit GUC requires a female thread on the piston rod end (Option 1 → F).

Motor type and size:
 - Leave blank: Without a motor

A
B

Motor type:
 - A: Stepper motor without a brake
 - B: Stepper motor with a brake

Motor size :
 - A: 28 mm (Available soon)
 - B: 42 mm
 - C: 56 mm

i Available sizes:
 - MCE 25: 28
 - MCE 32: 28, 42
 - MCE 45: 42, 56

For more details please refer to the section
 "Electrical data → Motor types and sizes"

Motor mounting option:

– Leave blank: Without a motor

Mounting option:

- A: With a motor adapter VK
- B: With a motor side drive MSD facing up
- C: With a motor side drive MSD facing right
- D: With a motor side drive MSD facing down
- E: With a motor side drive MSD facing left

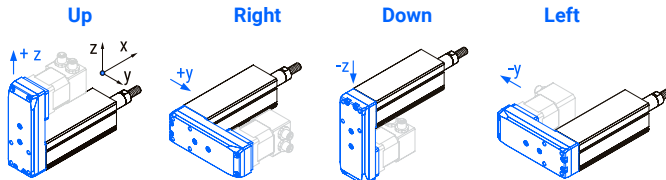

Direction of the motor connectors:

- U: Connectors facing up
- R: Connectors facing right
- D: Connectors facing down
- L: Connectors facing left

In combination with a motor adapter VK

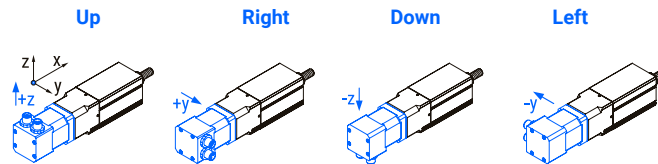

In combination with a motor side drive MSD

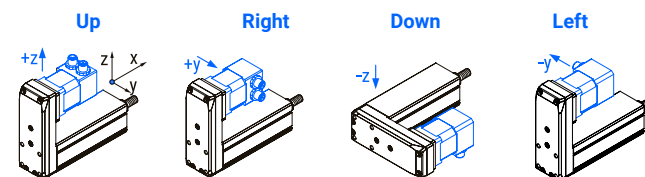

i If a guiding unit GUC is considered, the motor side drive MSD can only be facing in the up or down directions, otherwise, the motor and the guiding unit may collide!

i When using the motor side drive MSD, the connectors can not be facing the MCE otherwise, the connectors and MCE may collide. These combinations are: BD, CL, DU and ER.

Drive option:

– Leave blank: Without a motor or drive

Drive type:

– A: Stepper

i For more details please refer to the section "Electrical data → Drive types"

Drive-motor cables option:

– Leave blank: Without a motor or drive
– 00: Without the cables

Cables type:

- A: Robotic with a straight plug
- B: Robotic with an angled plug

Power and signal cables:

– Leave blank: Without a motor or drive

Power cable:

- 0: Without a power cable
- A: With a power cable

i Length of the cable = 2 m

For more details please refer to the section "Electrical data → Power and signal cables"

Drive protocol/control:

- A: EtherCAT
- B: Ethernet based communication
- C: Pulse-direction control

Cables Length:

- A: 3 m
- B: 5 m
- C: 10 m

i For more details please refer to the section "Electrical data → Drive-motor cables"

Signal cable:

- 0: Without a signal cable
- A: With a signal cable

i Length of the cable = 2 m

Signal cable is mandatory for the following cases:

- If a motor with brake is used
- If a pulse-direction drive control is used
- If the limit switches are used

For more details please refer to the section "Electrical data → Power and signal cables"

TECHNICAL DATA

General technical data

MCE	Ball screw ⁴	Dynamic axial load capacity ¹	Axial backlash (BS) ²	Max. angle of piston rod rotation ³	Max. repeatability ⁵	Absolute stroke
	d × l [mm]	C _a [N]	[mm]	[°]	[mm]	[mm]
25	6 × 2	1900	≤ 0,05	≤ ±1	±0,015	25, 50, 75, 100, 125, 150, 175, 200
	6 × 6	1700				
32	8 × 2	2000	≤ 0,06	≤ ±1	±0,015	25, 50, 75, 100, 125, 150, 175, 200
	8 × 8	1500				
45	10 × 3	3500	≤ 0,06	≤ ±1	±0,015	25, 50, 75, 100, 125, 150, 175, 200
	10 × 10	3200				

¹ Dynamic axial load capacity of the ball screw drive. This value is the basis for calculating the service life.

² Valid for ball screw drive in new condition.

³ Regarding to anti-rotation piston rod device in new condition.

⁴ d = ball screw nominal diameter, l = ball screw lead (for one revolution).

⁵ Valid for one-directional axial load.

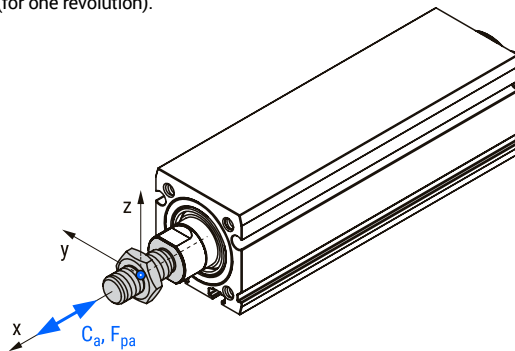

Drive data

Combination with a standard motor and a motor adapter VK

MCE + motor and VK	Ball screw	Motor		Max. permissible axial load ^{1,2}	Max. permissible payload ¹		Max. travel speed ²	Max. rotational speed	Max. acceleration
		Type	Size □ [mm]		Horizontal ^{2,3}	Vertical ²			
				d × l [mm]	F _{pa} [N]	m _{ph} [kg]	m _{pv} [kg]	v _{max} [m/s]	n _{max} [rev/min]
25	6 × 2	Stepper	28	170	57	14	0,100	3000	20
	6 × 6			90	13	7,4	0,300		
32	8 × 2		28	215	72	18	0,094	2810	20
			42	375	126	31	0,100		
	8 × 8		28	50	6,6	4,0	0,400	3000	
			42	200	35	17	0,400		
45	10 × 3		42	465	156	39	0,150	3000	20
			56	695	233	58	0,150		
	10 × 10		42	135	21	11	0,492	2950	
			56	580	133	49	0,500		

¹ This value depends on the selected motor, travel speed and acceleration of the piston rod (see the following diagrams).

² Valid for the entire stroke range. Guiding unit GUC is not taken into consideration.

³ Valid for the payload supported by an external guiding (coefficient of friction 0,1 is taken into consideration). Maximum unsupported payload (lateral load) is presented on the following diagrams.

Combination with a standard motor and a motor side drive MSD

MCE + motor and MSD	Ball screw d × l [mm]	Motor		Max. permissible axial load ^{1,2} F _{pa} [N]	Max. permissible payload ¹		Max. travel speed ² v _{max} [m/s]	Max. rotational speed n _{max} [rev/min]	Max. acceleration a _{max} [m/s ²]
		Type	Size □ [mm]		Horizontal ^{2,3} m _{ph} [kg]	Vertical ² m _{pV} [kg]			
25	6 × 2	Stepper	28	170	57	14	0,100	3000	20
	6 × 6			90	13	7,4	0,300		
32	8 × 2		28	180	60	15	0,064	1920	20
			42	375	126	31	0,100	3000	
	8 × 8		28	40	6,8	3,1	0,208	1560	
			42	175	35	15	0,400	3000	
45	10 × 3		42	400	134	33	0,148	2960	20
			56	695	233	58	0,150	3000	
	10 × 10		42	120	20	10	0,477	2860	
			56	450	133	38	0,500	3000	

Without a motor

MCE without a motor	Ball screw d × l [mm]	Max. permissible axial load ² F _{pa} [N]	Max. permissible payload		Max. drive torque M _p [Nm]	No load torque M ₀ [Nm]	Max. permissible radial load on shaft F _{pr} [N]	Max. travel speed ² v _{max} [m/s]	Max. rotational speed n _{max} [rev/min]	Max. acceleration a _{max} [m/s ²]
			Horizontal ^{2,3} m _{ph} [kg]	Vertical ² m _{pV} [kg]						
25	6 × 2	170	57	14	0,06	0,02	25	0,150	4500	20
	6 × 6	90	30	7	0,10	0,02		0,450		
32	8 × 2	375	126	31	0,13	0,04	50	0,150	4500	20
	8 × 8	375	126	31	0,53	0,05		0,600		
45	10 × 3	695	233	58	0,37	0,07	100	0,225	4500	20
	10 × 10	695	233	58	1,23	0,09		0,750		

¹ This value depends on the selected motor, travel speed and acceleration of the piston rod (see the following diagrams).

² Valid for the entire stroke range. Guiding unit GUC is not taken into consideration.

³ Valid for the payload supported by an external guiding (coefficient of friction 0,1 is taken into consideration). Maximum unsupported payload (lateral load) is presented on the following diagrams.

Operating conditions

Ambient temperature	0 °C ~ +50 °C
Ambient temperature without a motor	0 °C ~ +60 °C
Protection class	IP40
Duty cycle	100 %
Maintenance	Life-time pre-lubricated

i Recommended values of loads:
All the data of the dynamic load capacities (ball screw drive) stated in the tables above are theoretical without considering any safety factor. The safety factor depends on the application and its requested safety and service life.

We recommend a minimum dynamic safety factor of 5,0 or more. Please refer to page 95, where calculation of the safety factor of the ball screw drive and how the applied load affects the service life are presented.

Mass and mass moment of inertia

MCE without a motor	Ball screw	Moved mass*	Mass of the mini electric cylinder**	Mass moment of inertia
	d × l [mm]	$m_{m, MCE}$ [kg]	m_{MCE} [kg]	J_{MCE} [10^{-2} kg cm ²]
25	6 × 2	$0,06 + 0,0004 \times \text{Abs. stroke} + 0,0004 \times E$	$0,15 + 0,0013 \times \text{Abs. stroke} + 0,0004 \times E$	$0,28 + 0,0007 \times \text{Abs. stroke} + 0,00004 \times E + 0,1013 \times m_{load}$
	6 × 6			$0,33 + 0,0011 \times \text{Abs. stroke} + 0,00036 \times E + 0,9119 \times m_{load}$
32	8 × 2	$0,12 + 0,0005 \times \text{Abs. stroke} + 0,0005 \times E$	$0,31 + 0,0023 \times \text{Abs. stroke} + 0,0005 \times E$	$0,70 + 0,0025 \times \text{Abs. stroke} + 0,00005 \times E + 0,1013 \times m_{load}$
	8 × 8			$0,88 + 0,0033 \times \text{Abs. stroke} + 0,00077 \times E + 1,6211 \times m_{load}$
45	10 × 3	$0,20 + 0,0010 \times \text{Abs. stroke} + 0,0010 \times E$	$0,67 + 0,0043 \times \text{Abs. stroke} + 0,0010 \times E$	$2,77 + 0,0057 \times \text{Abs. stroke} + 0,00022 \times E + 0,2280 \times m_{load}$
	10 × 10			$3,23 + 0,0081 \times \text{Abs. stroke} + 0,00249 \times E + 2,5330 \times m_{load}$

* The moved mass is already considered in the equation for calculating the mass of the mini electric cylinder m_{MCE} and the mass moment of inertia J_{MCE} . The moved mass includes the mass of the piston rod with the internal anti-rotation device and ball nut.

** For combination with standard motor and motor adapter VK or motor side drive MSD this mass m_{MCE} should be increased by m_{VK+M} or m_{MSD+M} respectively, see the table below.

i Mass and moved mass of the guiding unit GUC are not included in the moved mass $m_{m,MCE}$, in the mass m_{MCE} and in the mass moment of inertia J_{MCE} . Please refer to the Guiding unit section for more information.

Abs. stroke	Absolute stroke	[mm]
E	Extended piston rod	[mm]
m_{load}	Applied mass to be moved	[kg]

Additional mass of an electric cylinder when combining the motor with the motor adapter VK or the motor side drive MSD

MCE	Motor		Motor without a brake		Motor with a brake	
			Mass of the motor and motor adapter VK	Mass of the motor and motor side drive MSD	Mass of the motor and motor adapter VK	Mass of the motor and motor side drive MSD
	Type	Size □ [mm]	m_{VK+m} [kg]	m_{MSD+m} [kg]	m_{VK+m} [kg]	m_{MSD+m} [kg]
25	Stepper	28	Available soon			
32		28	Available soon			
		42	0,52	0,62	0,65	0,75
		42	0,57	0,71	0,70	0,84
45		56	1,31	1,49	1,50	1,68

Planar moment of inertia

MCE	Cylinder profile	
	I_y [cm ⁴]	I_z [cm ⁴]
25	2,10	1,98
32	6,42	6,58
45	25,37	25,16

Holding torque of a motor brake

Motor	Holding torque (brake)		
	Type	Size □ [mm]	[Nm]
Stepper		28	Available soon
		42	0,4
		56	1,0

Maximum lateral loading as a function of the piston rod absolute position

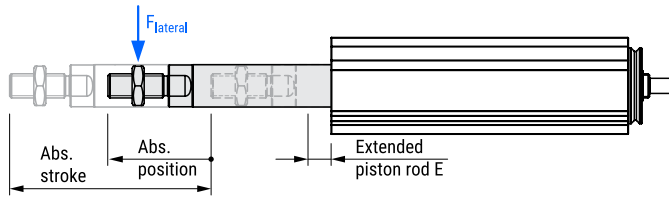

i On the following diagrams, the maximum lateral loads acting on the piston rod end as a function of the piston rod absolute position for different values of the absolute stroke are presented. There is also an extended piston rod (E) taken into consideration.

Values on the curves represent an absolute stroke of the cylinder. Diagrams consider the maximum travel speed of the particular size of the cylinder. When operating with lower travel speeds, the maximum lateral load may be higher.

MCE 25

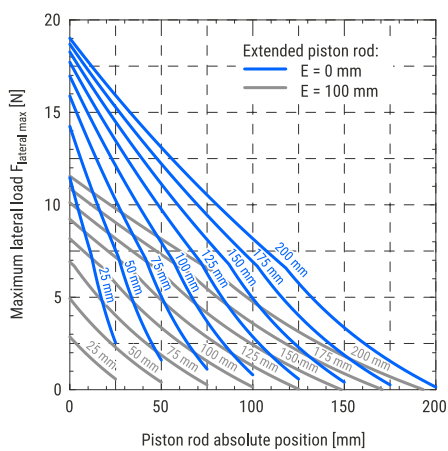

MCE 32

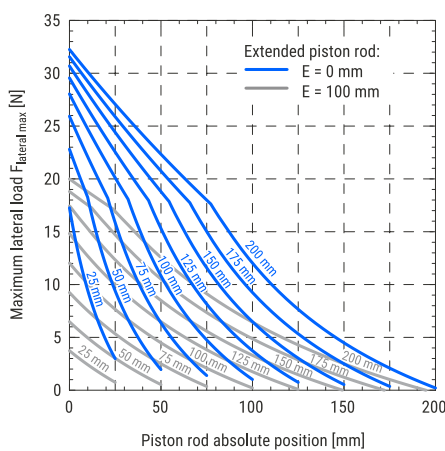

MCE 45

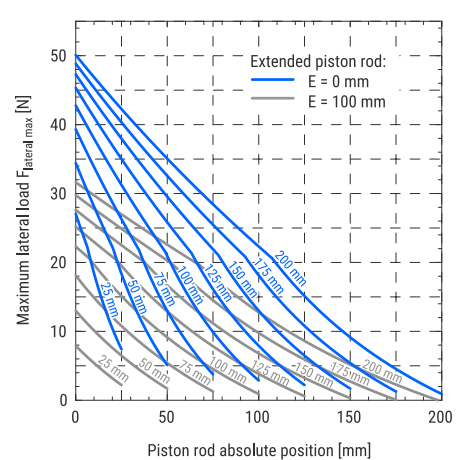

UNIMOTION

CALCULATE AND CONFIGURE YOUR OWN SOLUTION

The ELECTRIC CYLINDER CALCULATION TOOL is an online application that enables quick and easy selection of a suitable product, with the possibility of achieving the optimal ratio between the given capacity and price, including 3D CAD models.

For more information please contact us or visit our website.

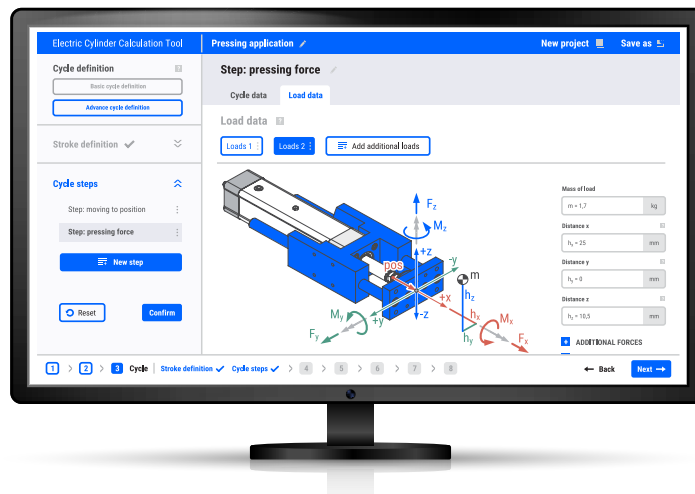

Maximum deflection of the piston rod end as a function of the cylinder absolute stroke

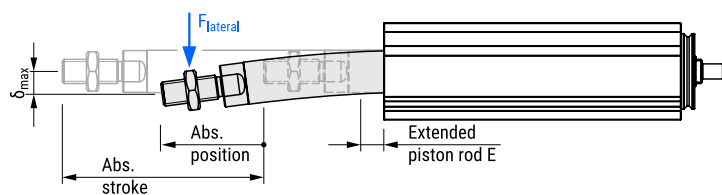

i On the following diagrams, the maximum deflections of the piston rod end subjected to different lateral loads for different absolute positions (defined as a portion of the absolute stroke) are presented. There is also an extended piston rod (E) taken into consideration.

Values on the curves represent lateral load applied to the piston rod end.

MCE 25

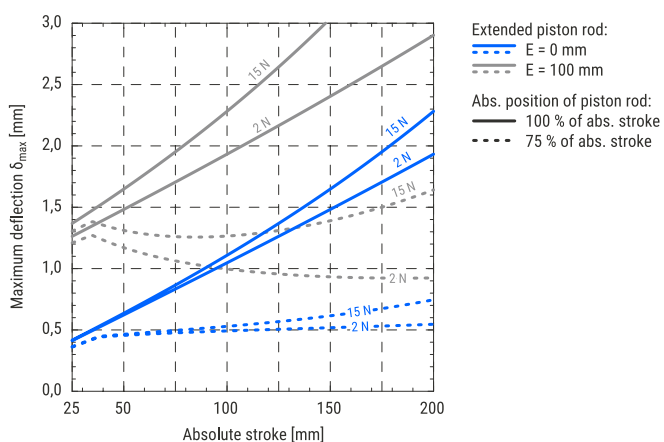

MCE 32

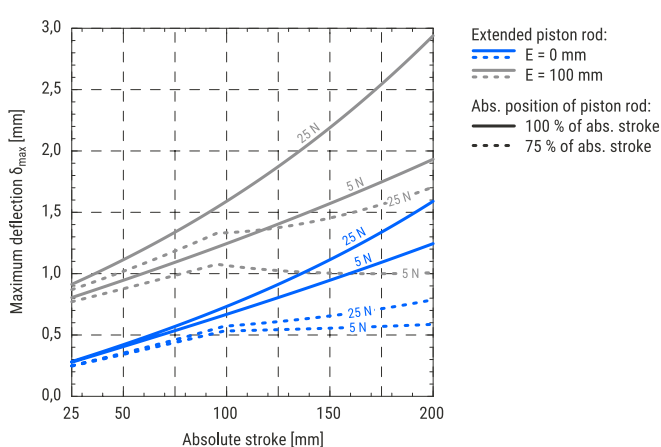

MCE 45

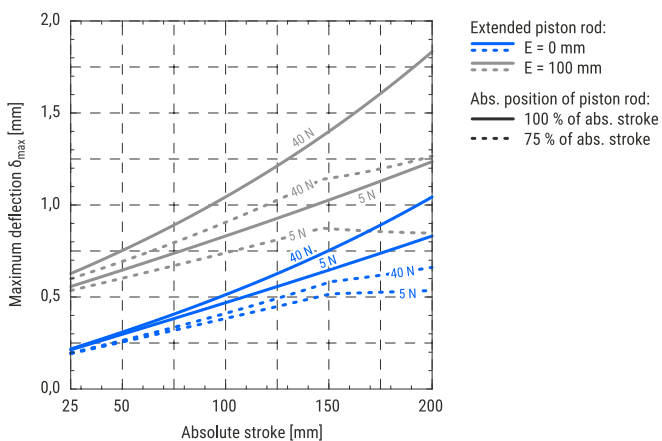

Maximum horizontal payload as a function of the travel speed and acceleration of the piston rod

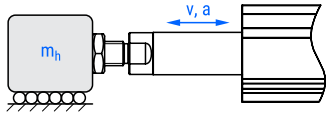

i On the following diagrams, the maximum horizontal payloads applied to the piston rod as a function of the travel speed for different accelerations, different ball screw leads and different combinations of the standard motors are presented. Motor adapter VK and a motor side drive MSD are also considered.

Diagrams are valid when the payload is supported by an external guiding (coefficient of friction 0,1 has been considered).

It should be noted that the diagrams are also valid for the case where a guiding unit GUC is considered.

MCE 25

6 × 2 with a stepper motor □28

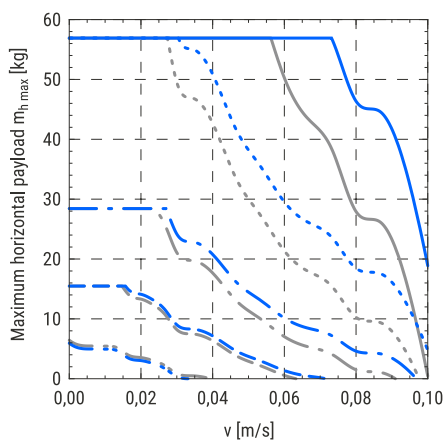

6 × 6 with a stepper motor □28

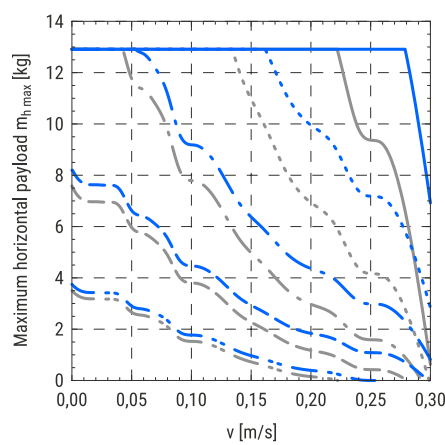

MCE in combination:

— with VK
 - - - with MSD

Acceleration/Deceleration:

— $a = 0,5 \text{ m/s}^2$
 - - - $a = 2 \text{ m/s}^2$
 — $a = 5 \text{ m/s}^2$
 - - - $a = 10 \text{ m/s}^2$
 - - - $a = 20 \text{ m/s}^2$

MCE 32

8 × 2 with a stepper motor □28

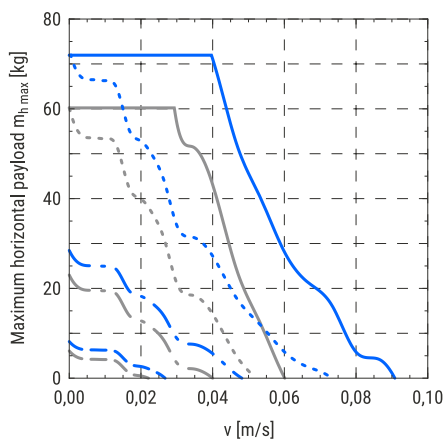

8 × 8 with a stepper motor □28



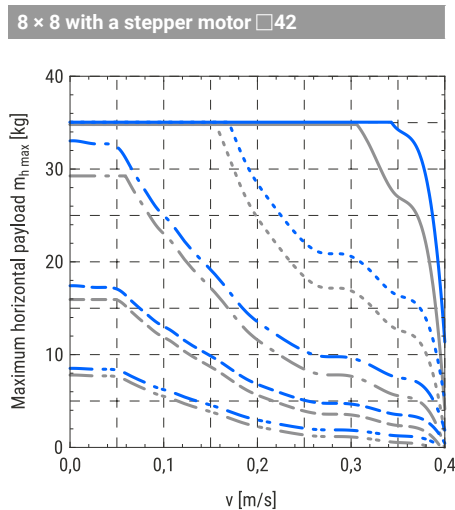
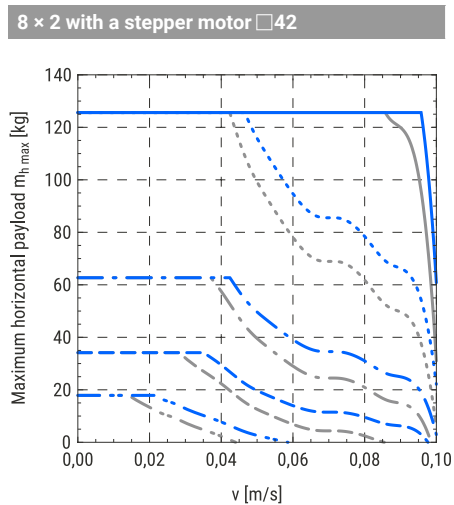

MCE in combination:
 — with VK
 — with MSD

Acceleration/Deceleration:
 — $a = 0,5 \text{ m/s}^2$
 - - - $a = 2 \text{ m/s}^2$
 - - - $a = 5 \text{ m/s}^2$
 - - - $a = 10 \text{ m/s}^2$
 - - - $a = 20 \text{ m/s}^2$

MCE 45

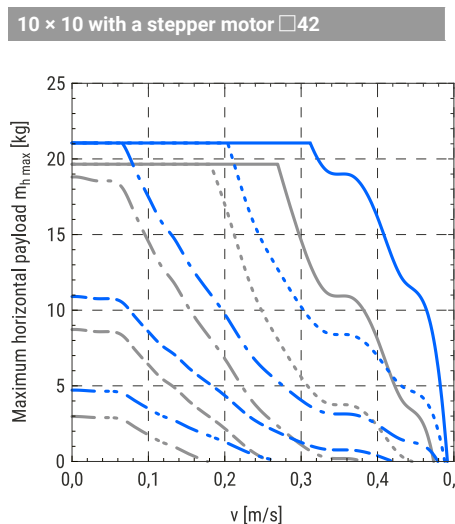
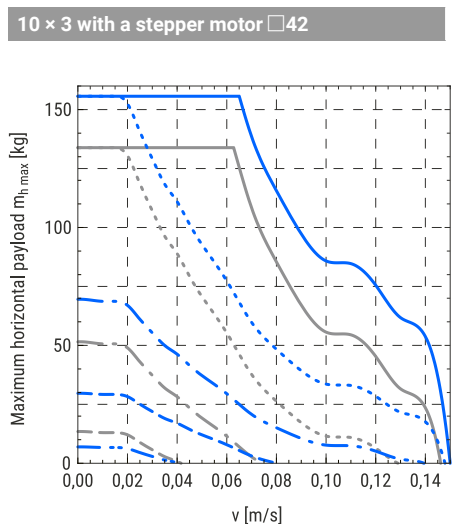

MCE in combination:
 — with VK
 — with MSD

Acceleration/Deceleration:
 — $a = 0,5 \text{ m/s}^2$
 - - - $a = 2 \text{ m/s}^2$
 - - - $a = 5 \text{ m/s}^2$
 - - - $a = 10 \text{ m/s}^2$
 - - - $a = 20 \text{ m/s}^2$

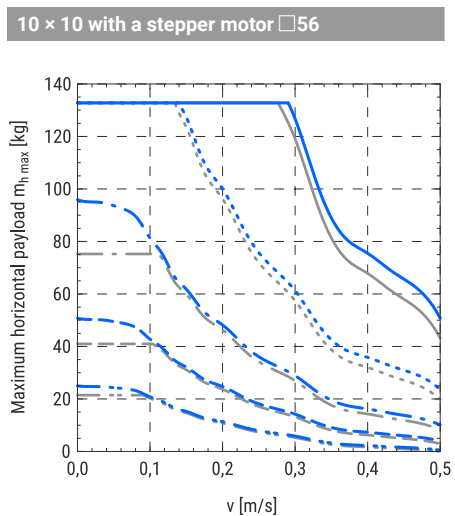
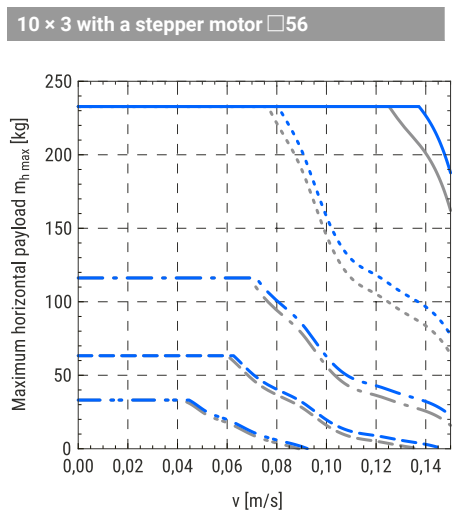

MCE in combination:
 — with VK
 — with MSD

Acceleration/Deceleration:
 — $a = 0,5 \text{ m/s}^2$
 - - - $a = 2 \text{ m/s}^2$
 - - - $a = 5 \text{ m/s}^2$
 - - - $a = 10 \text{ m/s}^2$
 - - - $a = 20 \text{ m/s}^2$

Maximum vertical payload as a function of the travel speed and acceleration of the piston rod

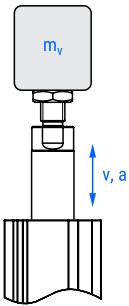

1 On the following diagrams, the maximum vertical payloads applied to the piston rod as a function of the travel speed for different accelerations, different ball screw leads and different combinations of the standard motors are presented. Motor adapter VK and a motor side drive MSD are also considered.

For the case that guiding unit GUC is taken into consideration, the value obtained from the diagram should be decreased by the moving mass of the guiding unit (please refer to the Guiding unit section).

MCE 25

6 × 2 with a stepper motor □28

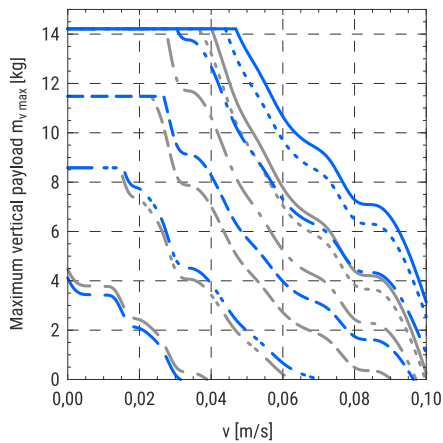

6 × 6 with a stepper motor □28

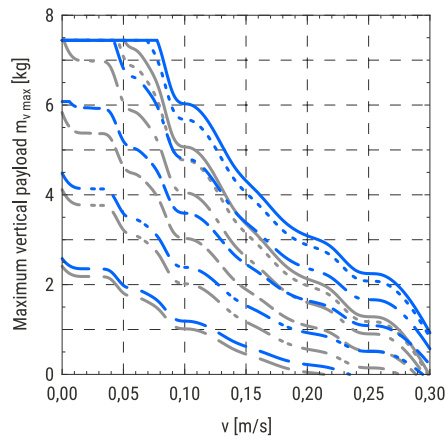

MCE in combination:
 — with VK
 — with MSD

Acceleration/Deceleration:
 — a = 0 m/s²
 - - - a = 0,5 m/s²
 - · - a = 2 m/s²
 - - - a = 5 m/s²
 - · - a = 10 m/s²
 - - - a = 20 m/s²

MCE 32

8 × 2 with a stepper motor □28

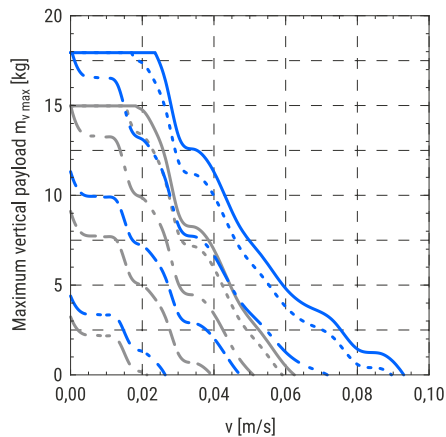

8 × 8 with a stepper motor □28

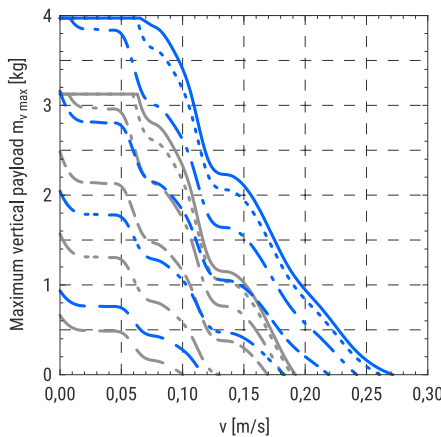

MCE in combination:
 — with VK
 — with MSD

Acceleration/Deceleration:
 — a = 0 m/s²
 - - - a = 0,5 m/s²
 - · - a = 2 m/s²
 - - - a = 5 m/s²
 - · - a = 10 m/s²
 - - - a = 20 m/s²

8 × 2 with a stepper motor □42

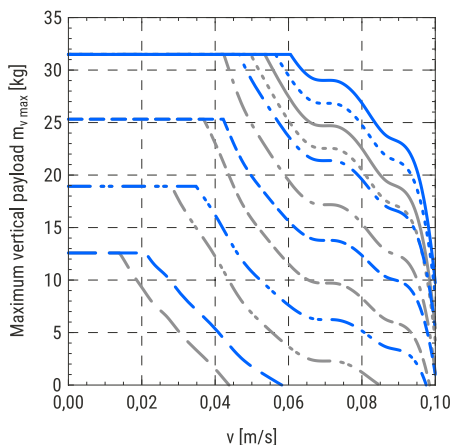

8 × 8 with a stepper motor □42

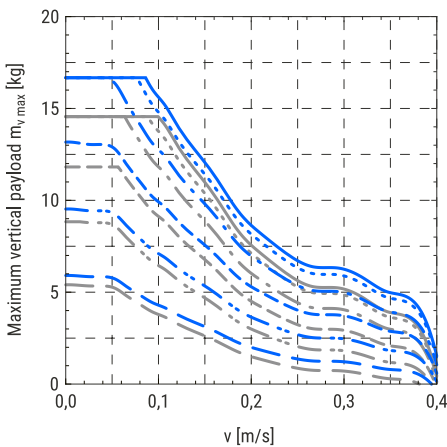

MCE in combination:
 — with VK
 - - with MSD

Acceleration/Deceleration:
 — a = 0 m/s²
 - - a = 0,5 m/s²
 - - a = 2 m/s²
 - - a = 5 m/s²
 - - a = 10 m/s²
 - - a = 20 m/s²

MCE 45

10 × 3 with a stepper motor □42

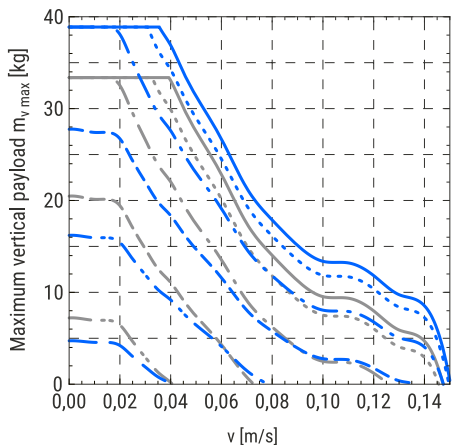

10 × 10 with a stepper motor □42

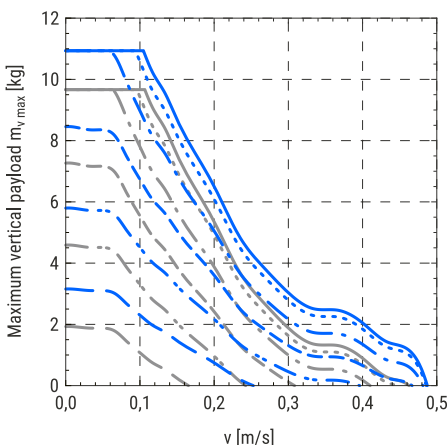

MCE in combination:
 — with VK
 - - with MSD

Acceleration/Deceleration:
 — a = 0 m/s²
 - - a = 0,5 m/s²
 - - a = 2 m/s²
 - - a = 5 m/s²
 - - a = 10 m/s²
 - - a = 20 m/s²

10 × 3 with a stepper motor □56

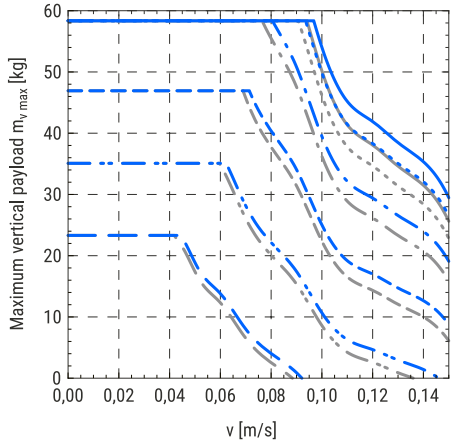

10 × 10 with a stepper motor □56

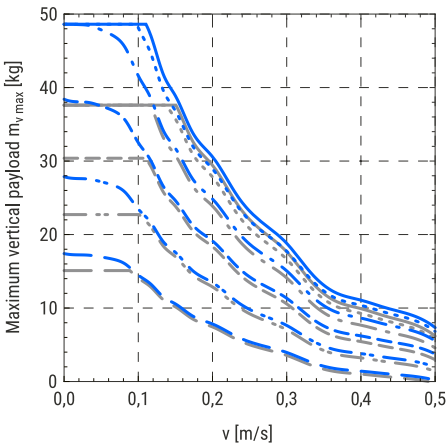

MCE in combination:
 — with VK
 - - with MSD

Acceleration/Deceleration:
 — a = 0 m/s²
 - - a = 0,5 m/s²
 - - a = 2 m/s²
 - - a = 5 m/s²
 - - a = 10 m/s²
 - - a = 20 m/s²

Maximum axial load as a function of the travel speed and acceleration of the piston rod

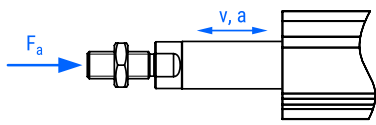

i On the following diagrams, the maximum axial load applied to the piston rod as a function of the travel speed for different accelerations, different ball screw leads and different combinations of the standard motors is presented. Motor adapter VK and a motor side drive MSD are also considered.

For the case where a guiding unit GUC is used, the value obtained from the diagram should be decreased by the moving mass of the guiding unit (please refer to the Guiding unit section) multiplied by the acceleration of the piston rod.

MCE 25

6 × 2 with a stepper motor □28

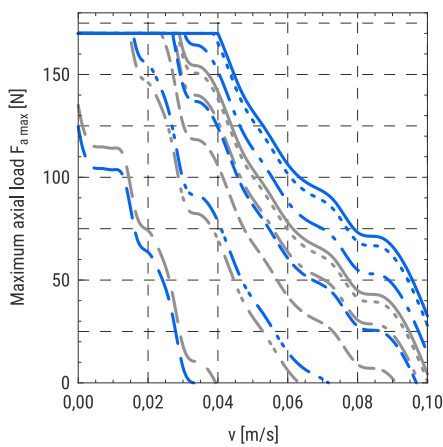

6 × 6 with a stepper motor □28

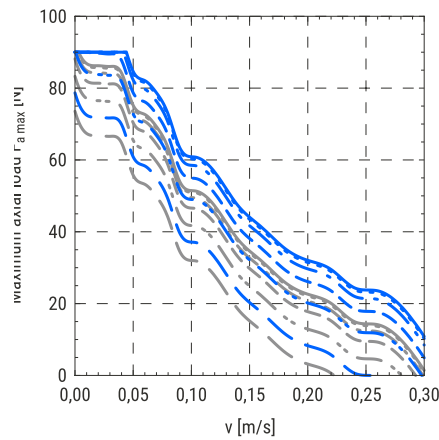

MCE in combination:
 — with VK
 — with MSD

Acceleration/Deceleration:
 — $a = 0 \text{ m/s}^2$
 - - - $a = 0,5 \text{ m/s}^2$
 - - - $a = 2 \text{ m/s}^2$
 - - - $a = 5 \text{ m/s}^2$
 - - - $a = 10 \text{ m/s}^2$
 - - - $a = 20 \text{ m/s}^2$

MCE 32

8 × 2 with a stepper motor □28

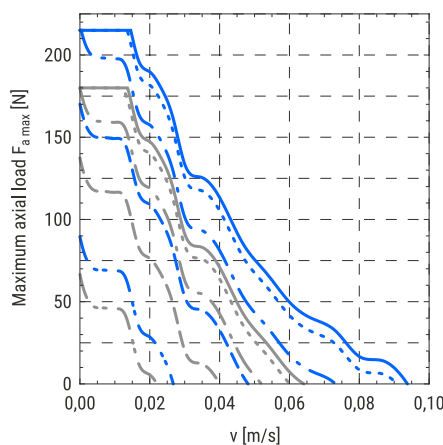

8 × 8 with a stepper motor □28

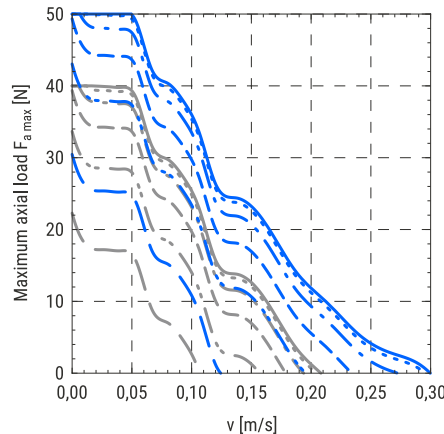

MCE in combination:
 — with VK
 — with MSD

Acceleration/Deceleration:
 — $a = 0 \text{ m/s}^2$
 - - - $a = 0,5 \text{ m/s}^2$
 - - - $a = 2 \text{ m/s}^2$
 - - - $a = 5 \text{ m/s}^2$
 - - - $a = 10 \text{ m/s}^2$
 - - - $a = 20 \text{ m/s}^2$

8 × 2 with a stepper motor □42

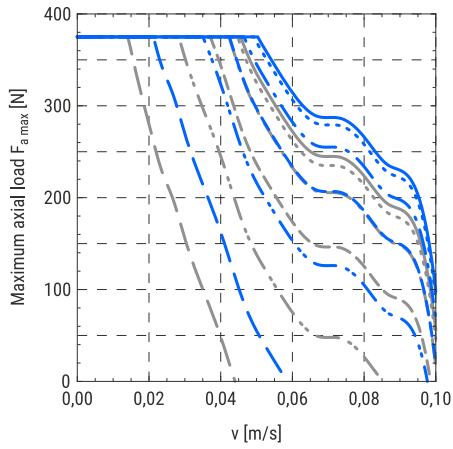

8 × 8 with a stepper motor □42

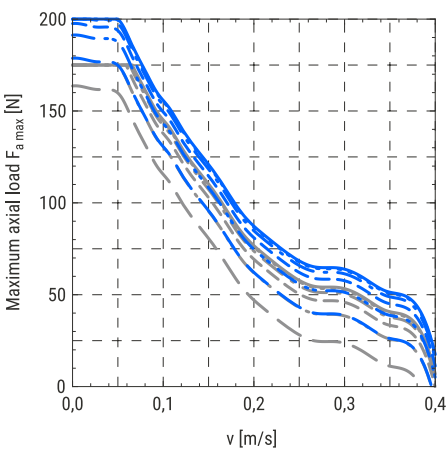

MCE in combination:
 — with VK
 — with MSD

Acceleration/Deceleration:
 — $a = 0 \text{ m/s}^2$
 - - - $a = 0,5 \text{ m/s}^2$
 - - - $a = 2 \text{ m/s}^2$
 - - - $a = 5 \text{ m/s}^2$
 - - - $a = 10 \text{ m/s}^2$
 - - - $a = 20 \text{ m/s}^2$

MCE 45

10 × 3 with a stepper motor □42

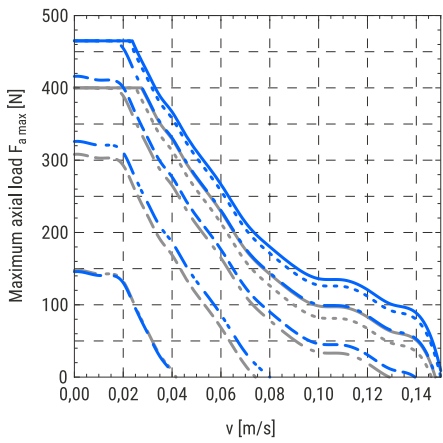

10 × 10 with a stepper motor □42

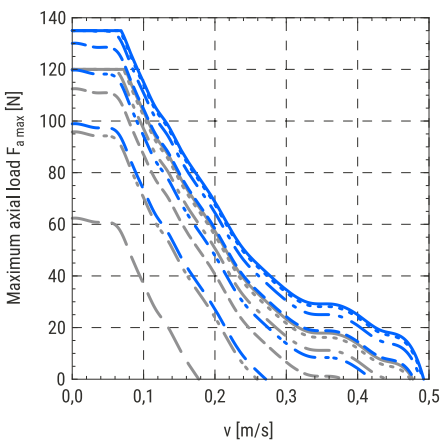

MCE in combination:
 — with VK
 — with MSD

Acceleration/Deceleration:
 — $a = 0 \text{ m/s}^2$
 - - - $a = 0,5 \text{ m/s}^2$
 - - - $a = 2 \text{ m/s}^2$
 - - - $a = 5 \text{ m/s}^2$
 - - - $a = 10 \text{ m/s}^2$
 - - - $a = 20 \text{ m/s}^2$

10 × 3 with a stepper motor □56

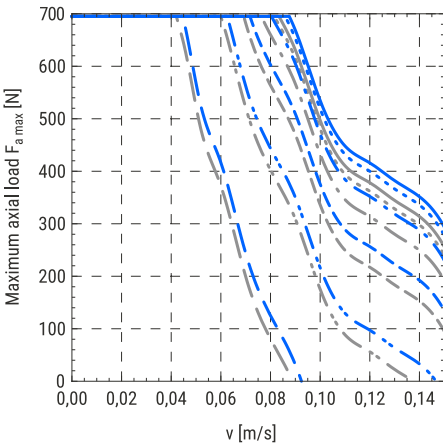

10 × 10 with a stepper motor □56

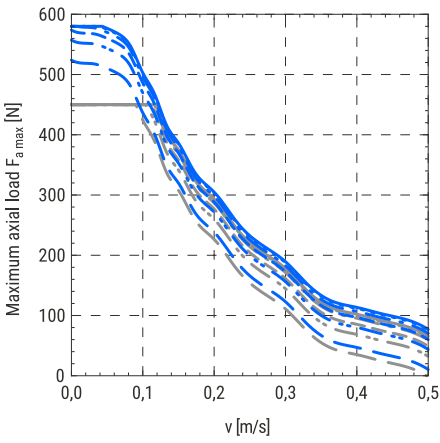

MCE in combination:
 — with VK
 — with MSD

Acceleration/Deceleration:
 — $a = 0 \text{ m/s}^2$
 - - - $a = 0,5 \text{ m/s}^2$
 - - - $a = 2 \text{ m/s}^2$
 - - - $a = 5 \text{ m/s}^2$
 - - - $a = 10 \text{ m/s}^2$
 - - - $a = 20 \text{ m/s}^2$

Maximum horizontal payload as a function of change of the position and positioning time of the piston rod

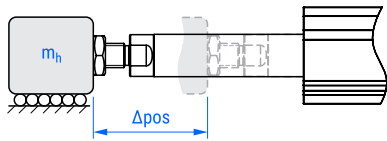

1 The following diagrams show the maximum payload that can be moved by a certain horizontal distance within a positioning time frame. Acceleration/deceleration time of 100 ms is taken into account.

Diagrams depend on the ball screw leads and different combinations of the standard motors. Motor adapter VK and a motor side drive MSD are also considered.

Diagrams are valid when the payload is supported by an external guiding (coefficient of friction 0,1 has been considered).

It should be noted that the diagrams are also valid for the case where a guiding unit GUC is considered.

MCE 25

6 × 2 with a stepper motor □28

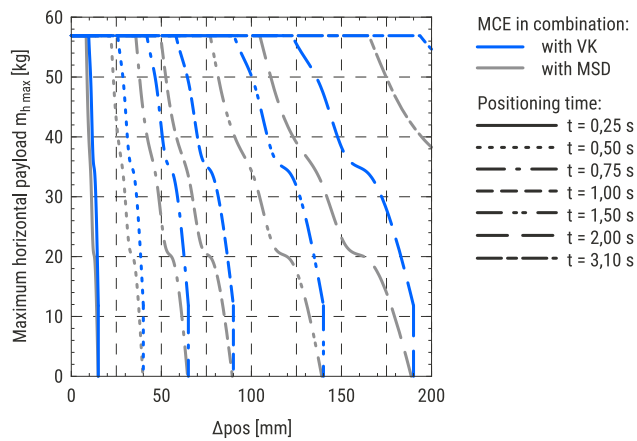

6 × 6 with a stepper motor □28

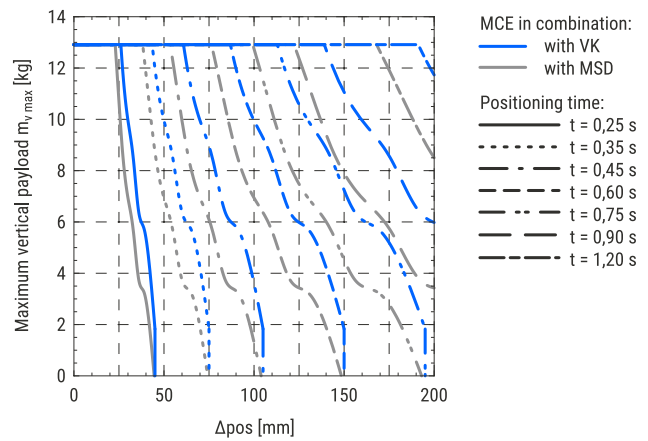

MCE 32

8 × 2 with a stepper motor □28

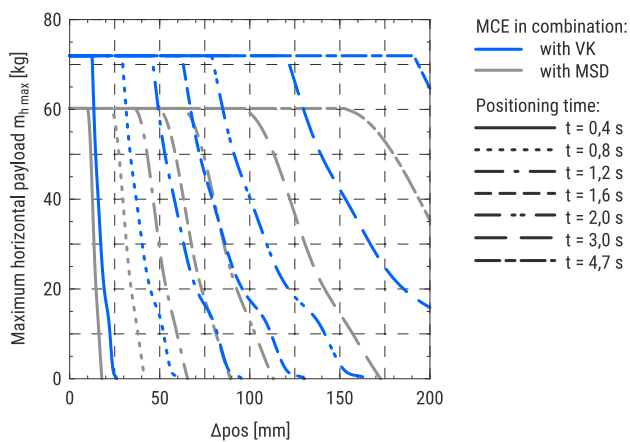

8 × 8 with a stepper motor □28

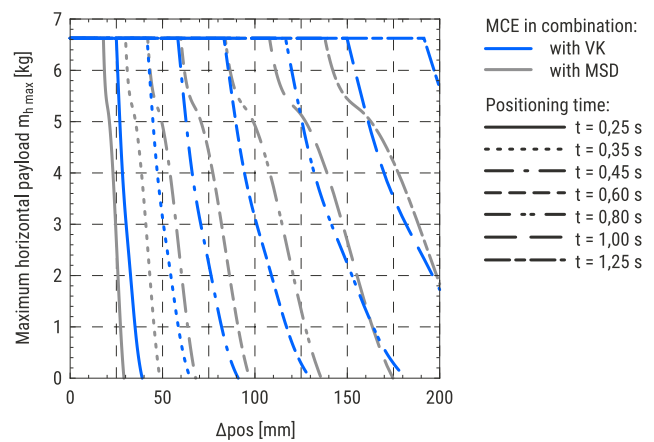

8 × 2 with a stepper motor □42

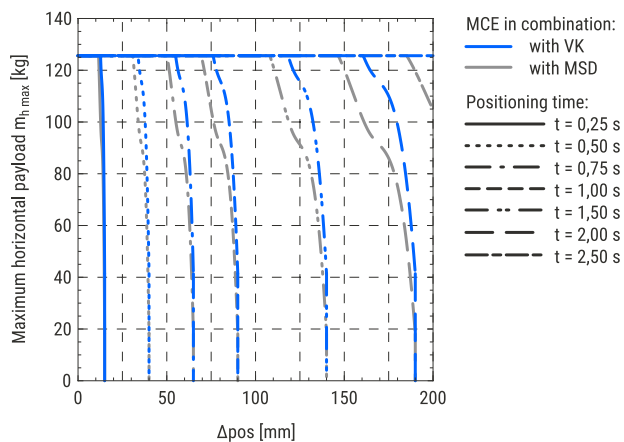

8 × 8 with a stepper motor □42

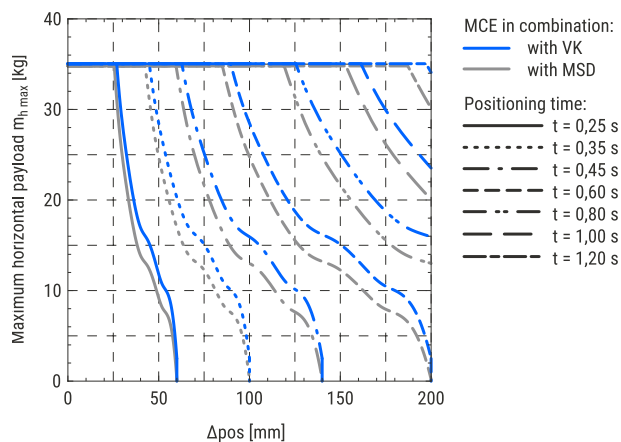

MCE 45

10 × 3 with a stepper motor □42

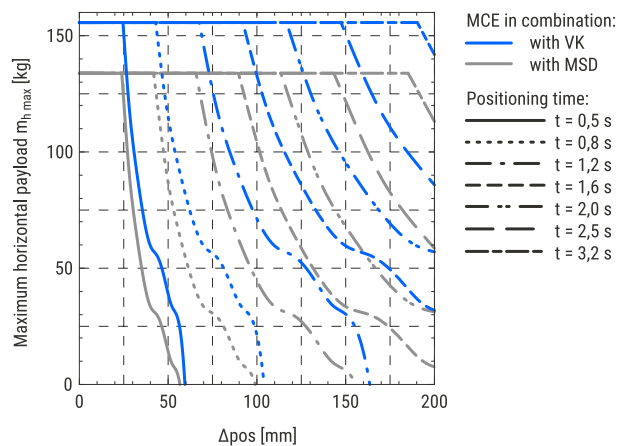

10 × 10 with a stepper motor □42

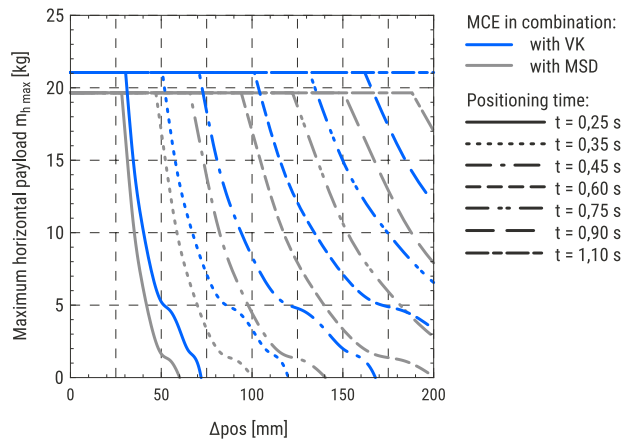

10 × 3 with a stepper motor □56

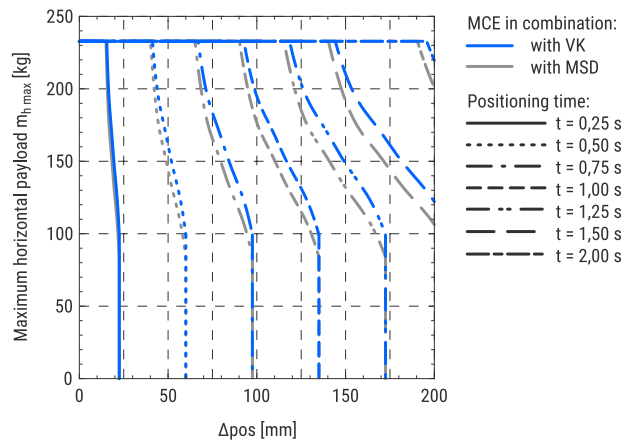

10 × 10 with a stepper motor □56

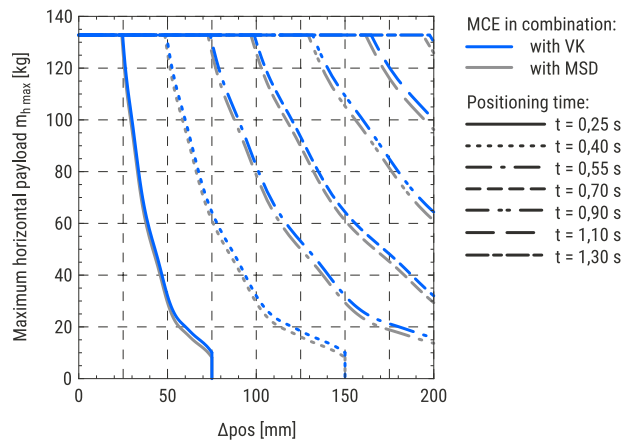

Maximum vertical payload as a function of change of the position and positioning time of the piston rod

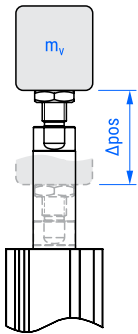

i The following diagrams show the maximum payload that can be moved by a certain vertical distance within a positioning time frame. Acceleration/deceleration time of 100 ms is taken into account.

Diagrams depend on the ball screw leads and different combinations of the standard motors. Motor adapter VK and a motor side drive MSD are also considered.

For the case where a guiding unit GUC is used, the value obtained from the diagram should be decreased by the moving mass of the guiding unit (please refer to the Guiding unit section).

MCE 25

6 × 2 with a stepper motor □28

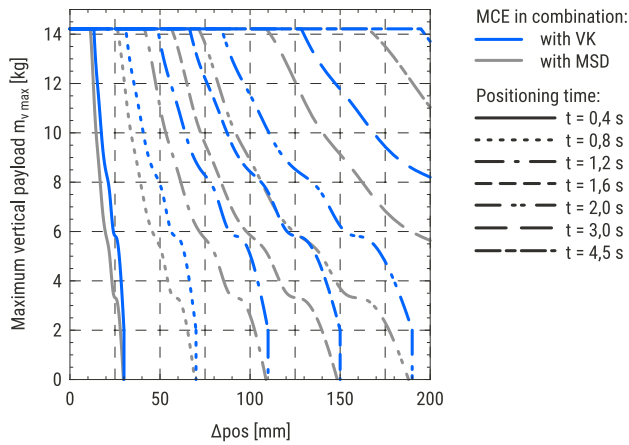

6 × 6 with a stepper motor □28

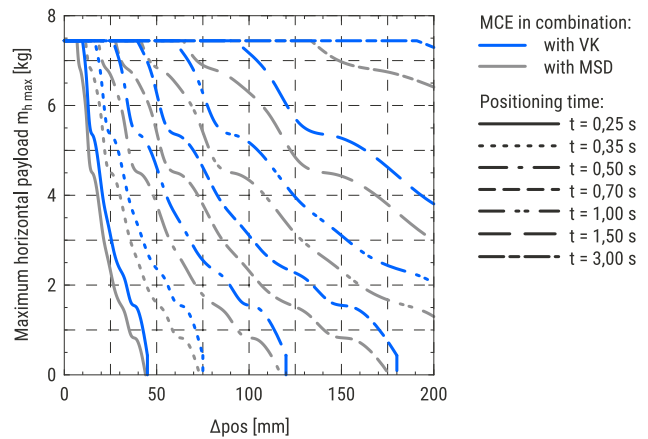

MCE 32

8 × 2 with a stepper motor □28

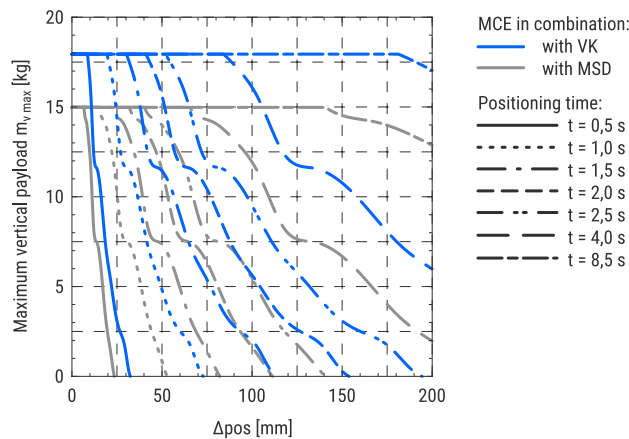

8 × 8 with a stepper motor □28

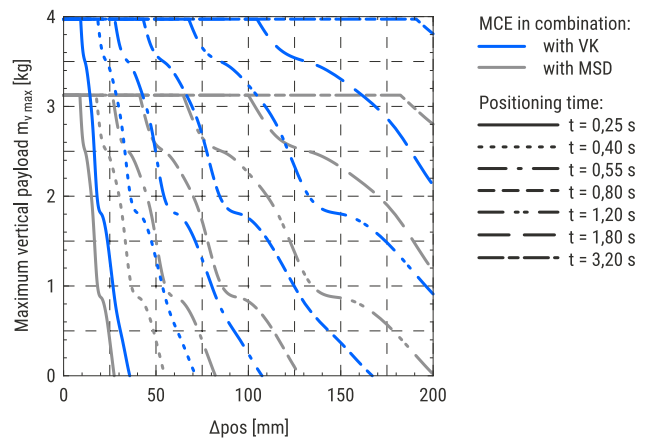

8 × 2 with a stepper motor □42

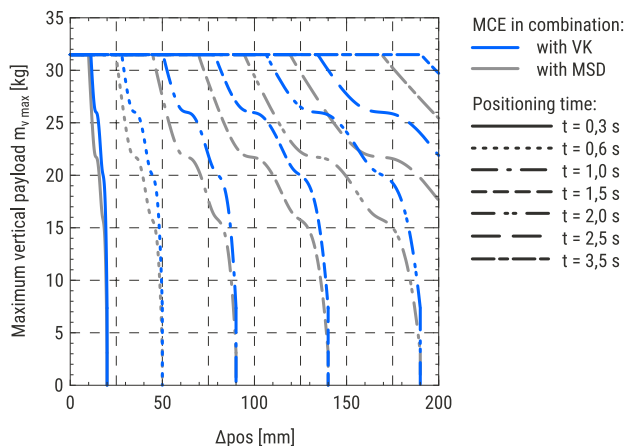

8 × 8 with a stepper motor □42

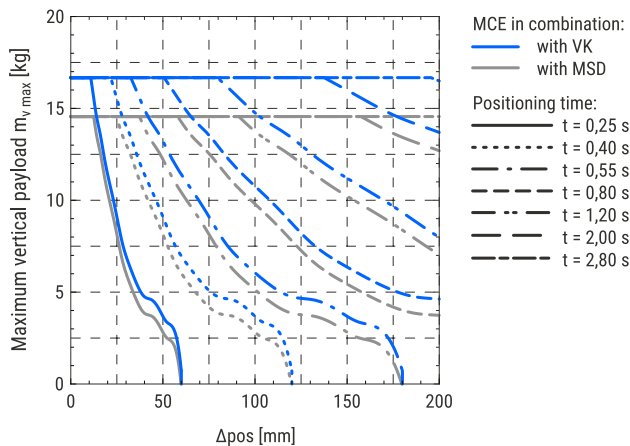

MCE 45

10 × 3 with a stepper motor □42

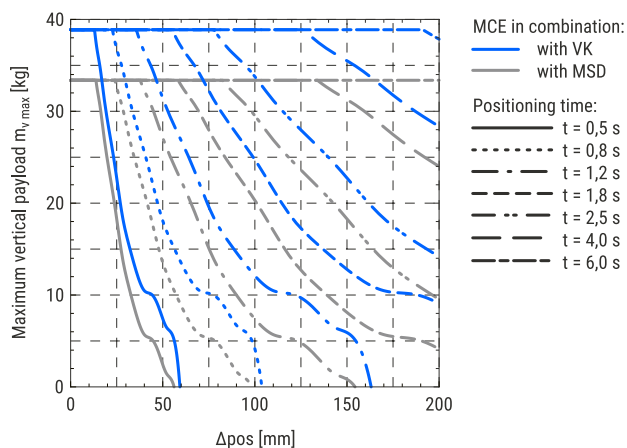

10 × 10 with a stepper motor □42

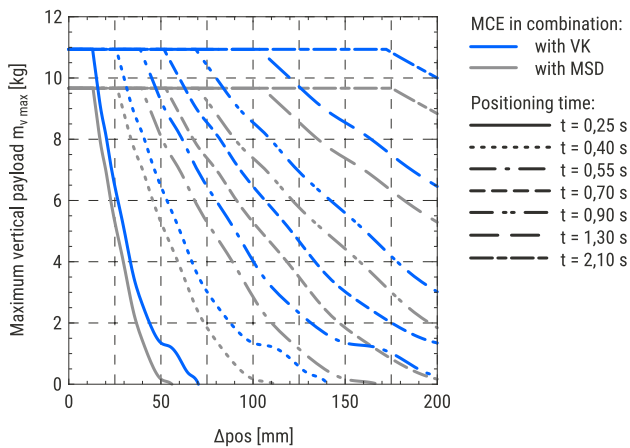

10 × 3 with a stepper motor □56

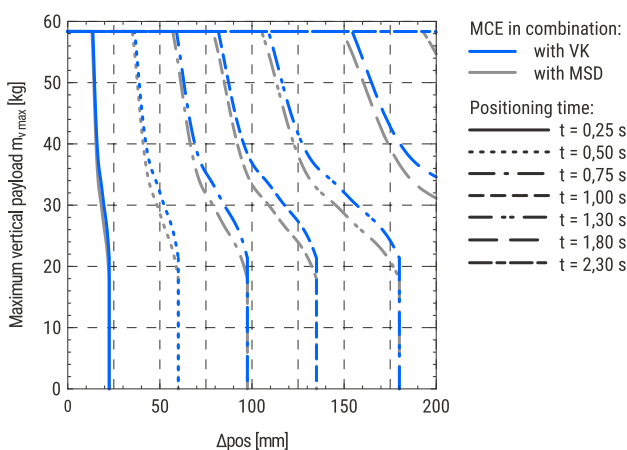

10 × 10 with a stepper motor □56

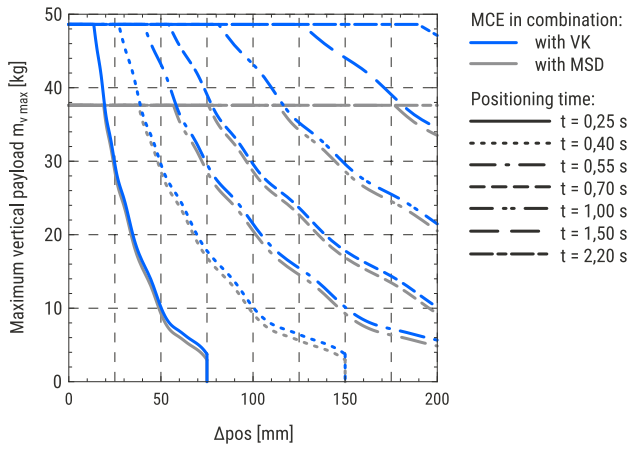

DIMENSIONS

i All dimensions are in mm. The scale of the drawings may not be equal.

MCE in combination with a standard motor and a motor adapter VK

- * E1: motor connection
- E2: encoder connection
- E3: brake connection

** ... + Abs. position

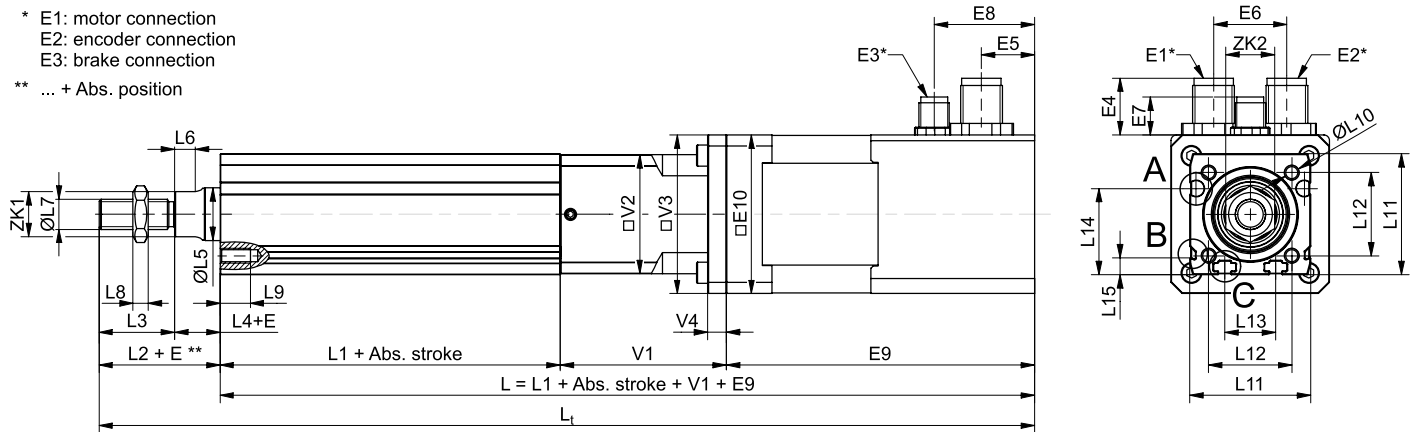

A (MCE 25)

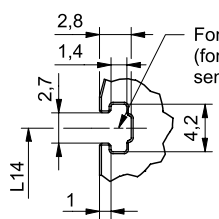

A (MCE 32)

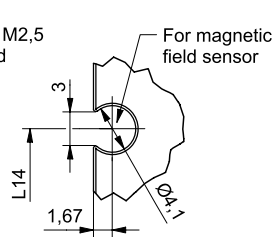

A (MCE 45)

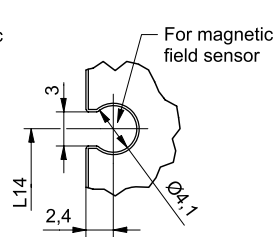

B

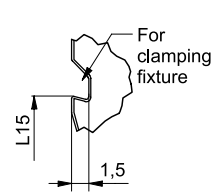

C

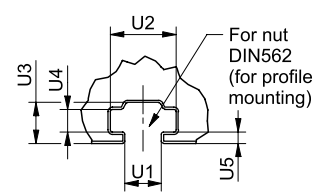

MCE in combination with a standard motor and a motor side drive MSD

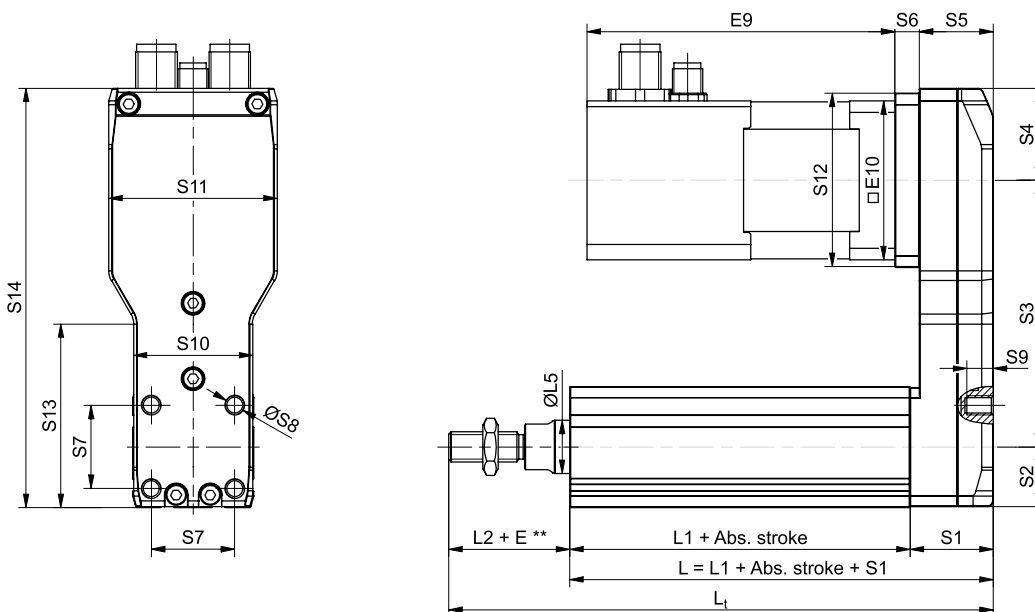

MCE without a motor

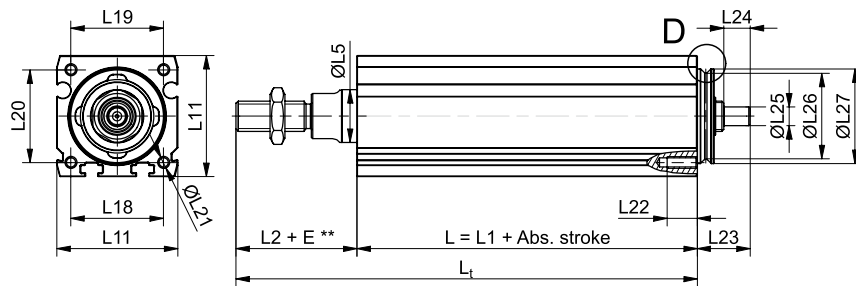

Female thread

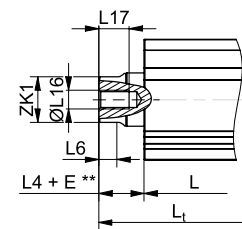

MCE dimensions

MCE	L1	L2	L3	L4	ØL5	L6	ØL7	L8	L9	ØL10	L11	L12	L13	L14	L15	ØL16	L17	L18	L19	L20	ØL21	L22	L23	L24	ØL25 (h7)	ØL26	ØL27 (h7)	
	[mm]																											
25	50	26	16	10	12	3,5	M6 x 1	3,2	8	M2,5	25	21	13,5	19,25	4,4	M4	8	19	17	18	M2,5	8	14	7	5	17,6	20	
32	65	32	20	12	14	5,5	M8 x 1,25	4	8	M4	32	22	13,5	22,8	4,4	M5	8	24,5	24,5	24,5	M3	8	14	7	5	22,6	25	
45	80	38	22	16	18	7	M10 x 1,25	5	12	M6	45	32	20	30,5	4,4	M6	12	34	34	34	M4	10	16	8	8	31,6	34	

MCE	L28	L29	ZK1	ZK2	U1	U2	U3	U4	U5
	[mm]								
25	4,5	2,3	10	10	2,2	4,2	2,8	1,4	1
32	4,5	2,3	12	13	3,2	5,8	3,6	2	1
45	4,5	2,3	16	17	4,2	7,5	4,7	2,5	1,2

Motor adapter VK and a motor side drive MSD dimensions

MCE	Motor		V1	□V2	□V3	V4	S1	S2	S3 (±0,5)	S4	S5	S6	S7	ØS8	S9	S10	S11	S12	S13	S14
	Type	Size □ [mm]	[mm]																	
25	Stepper	28	36	24,5	28	5,5	22	12,5	52,5	18,25	19,5	5,5	18	M4	6	24,5	31,5	34	38,5	83,25
32		28	36	31,5	31,5	0	22	16,0	52,5	18,25	19,5	5,5	22	M5	7	31,5	31,5	34	0	86,75
		42	40	31,5	42	5,5	22	16,0	70,5	24,25	19,5	6,5	22	M5	7	31,5	44,5	46	48	110,75
45		42	42	44,5	44,5	0	27,5	22,5	81	24,75	24,5	6,5	32	M6	7	44,5	44,5	46	0	128,25
		56	46	44,5	56,4	9,5	27,5	22,5	88,5	33,25	24,5	6	32	M6	7	44,5	59,5	59,5	64,5	144,25

Motor dimensions

Motor			E1	E2	E3	E4 (±1)	E5 (±0,3)	E6	E7 (±1)	E8 (±0,3)	E9 (±1)	□E10
Type	Size □ [mm]	Brake	[mm]									
Stepper	28	–	Available soon									
	28	with										
	42	–	M12 5-pole	M12 8-pole	–	14	14	19,5	–	–	70,4	42,3
	42	with	M12 5-pole	M12 8-pole	M8 3-pole	14	14	19,5	9	27	106,4	42,3
	56	–	M12 5-pole	M12 8-pole	–	14	13,4	23	–	–	98	56,4
	56	with	M12 5-pole	M12 8-pole	M8 3-pole	14	52,4	23	9	12	138	56,4

Absolute stroke and length of the MCE definition

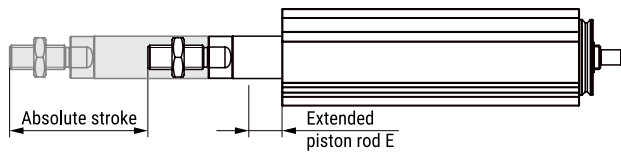

Absolute stroke definition

Absolute stroke = Effective stroke + 2 × Safety stroke

i The electric cylinder MCE does not include any safety stroke.

Length definition

$L_t = L + L_2 + E + \text{Abs. position}$

Female thread:

$L_t = L + L_4 + E + \text{Abs. position}$

i Length L and L_t are defined as it is presented on the dimensional drawings above, where lengths of a motor, a motor adapter VK and a motor side drive MSD are also considered.

Abs. stroke	Absolute stroke	[mm]
Abs. position	Absolute position	[mm]
E	Extended piston rod	[mm]
L	Length	[mm]
L_t	Total length	[mm]

i $E_{\max} = 100 \text{ mm}$.

ACCESSORIES

