

**MAC050 - MAC141  
MAC400 - MAC402 - MAC800  
MAC1500 - MAC3000**

# **Integrated Servo Motors**

## **User Manual**

**Including expansion modules**



**JVL Industri Elektronik A/S**



# Important User Information



## Warning



The MAC series of products are used to control electrical and mechanical components of motion control systems. You should test your motion system for safety under all potential conditions. Failure to do so can result in damage to equipment and/or serious injury to personnel.

Please contact your nearest JVL representative in case of technical assistance. Your nearest contact can be found on our web site [www.jvl.dk](http://www.jvl.dk)

Copyright 1998-2019, JVL Industri Elektronik A/S. All rights reserved. This user manual must not be reproduced in any form without prior written permission of JVL Industri Elektronik A/S. JVL Industri Elektronik A/S reserves the right to make changes to information contained in this manual without prior notice. Similarly JVL Industri Elektronik A/S assumes no liability for printing errors or other omissions or discrepancies in this user manual.

*MacTalk and MotoWare are registered trademarks*

JVL Industri Elektronik A/S  
Bregnerødvej 127  
DK-3460 Birkerød  
Denmark  
Tlf. +45 45 82 44 40  
Fax. +45 45 82 55 50  
e-mail: [jvl@jvl.dk](mailto:jvl@jvl.dk)  
Internet: <http://www.jvl.dk>





# Contents

<b>I</b>	<b>Introduction .....</b>	<b>3</b>
1.1	Features .....	4
1.2	Overall description .....	5
1.3	Expansion modules overview .....	10
1.4	Using MacTalk to setup the motor .....	14
<b>2</b>	<b>Function description .....</b>	<b>19</b>
2.1	Using Position mode .....	20
2.2	Gear Mode .....	21
2.3	Coil Mode .....	24
2.4	Analogue bi position mode .....	27
2.5	Analogue to position mode .....	28
2.6	Mechanical Zero search .....	32
2.7	Error messages and error handling .....	40
2.8	How to monitor the motor torque and load .....	51
2.9	Under Voltage Handling .....	52
2.10	Servo filter adjustment .....	53
2.11	Using external SSI encoder .....	59
2.12	Absolute Multiturn Encoder .....	65
2.13	Rotary table option .....	74
2.14	Power Save .....	80
2.15	Scope Function .....	81
2.16	Safe Torque Off (STO) .....	82
<b>3</b>	<b>Hardware description .....</b>	<b>85</b>
3.1	Connector overview .....	86
3.2	Power Supply .....	87
3.3	Serial interface .....	109
3.4	User I/O .....	110
<b>4</b>	<b>Expansion Modules .....</b>	<b>117</b>
4.1	Expansion Module MAC00-CS .....	118
4.2	Expansion Module MAC00-B1/B2/B4 .....	119
4.3	Expansion module MAC00-B41 .....	135
4.4	Expansion module MAC00-B42 .....	152
4.5	Expansion module MAC00-Exx4 .....	158
4.6	Expansion Mod. MAC00-FC2/FC4/FC41 .....	159
4.7	Expansion Module MAC00-FD4 .....	225
4.8	Expansion Module MAC00-FP2/FP4 .....	249
4.9	Expansion Module MAC00-FS1/FS4 .....	269
4.10	Expansion module MAC00-P4/P5 .....	275
4.11	Expansion Module MAC00-R1/R3/R4 .....	291
<b>5</b>	<b>Appendix .....</b>	<b>331</b>
5.1	Technical Data .....	332
5.2	Torque Curves .....	338
5.3	Efficiency curve .....	341
5.4	Physical Dimensions .....	342
5.5	Life time .....	351
5.6	Installation instructions .....	354
5.7	Emergency stop considerations .....	360
5.8	Trouble-shooting guide .....	366
5.9	Bus serial communication .....	368
5.10	Serial communication .....	371
5.11	MacTalk communication .....	378
5.12	Internal registers .....	382
5.13	Connecting to other equipment .....	412
5.14	Accessories .....	415
5.15	Cable drawings .....	417
5.16	Vibration test certificates .....	419
5.17	CE Declaration of Conformity .....	422
5.18	UL Certificate of Compliance .....	424





## 1.1

## Features



The MAC series of brushless servo motors with integrated electronics represents a major step forward in motion control systems. All of the necessary electronics for a servo system are integrated into the motor itself.

Traditional motor systems typically have the controller and drive electronics placed some distance away from the motor. This increases machine costs and has the negative effect that installation time and costs are a major part of the total expense of building machinery.

The basic idea of the MAC motor is to minimise these costs, but also to make a component that is much better protected against electrical noise which can be a typical problem when using long cables between a controller and motor.

All user inputs and outputs are filtered, which means that the MAC motors will work properly even in an environment with a high level of electrical noise.

The major advantages are:

- Lower installation costs
- Faster installation
- Quiet and maintenance-free operation
- Replacement for pneumatic solutions
- Replacement for step motors, offering much faster response
- Great flexibility due to many I/O possibilities and many functions.
- Less machine space required.
- Fewer possibilities for wiring errors.

### Main Features:

- Low cost and high performance make the MAC series ideal for high-volume applications
- Pulse and direction inputs make it possible to replace step motors.
- Quadrature input for gearing applications.
- $\pm 10V$  input for controlling speed and torque
- 2 ch. Quadrature output to master controller when used as driver.
- Accepts position and velocity commands sent via RS232/422 interface.
- Wide supply voltage range 12 to 48VDC, 90 to 240VAC and 3 x 400-480VAC.
- Excellent efficiency compared to step motors.
- Resolution 4096, 8000 or 8192 cpr.
- Wide variety of expansion modules which can be mounted internally:
  - Profibus DP module
  - CAN-Open® or DeviceNet module
  - Ethernet modules
  - nano-PLC w/graphic programming
  - Several module connector options
  - Custom-designed modules on request
- Outputs for *In position* and *Error* indication.
- High order digital filter which only needs a single inertia adjustment.
- Standard NEMA23 flange.
- Built-in sensors make the motor stay stationary when powering up.
- Easy and simple Windows program - Mac-Talk available for installation/setup.
- High-efficiency power stage keeps temperature at a low level.
- CE approved. UL recognized (MAC400 and 800 - MAC1500 & 3000 pending)

## 1.2

## Overall description

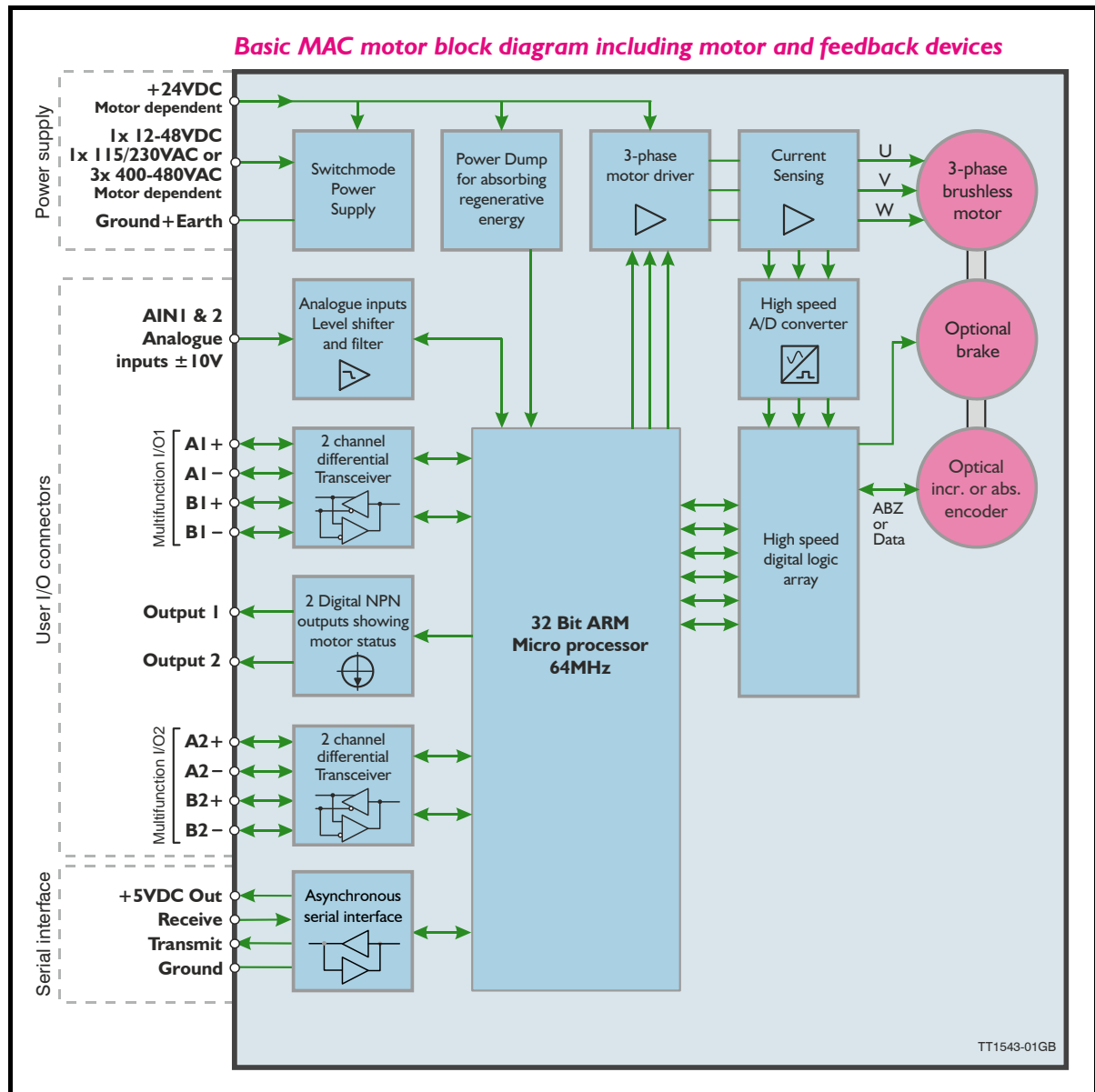

All the internal building blocks of the MAC motor are shown in the illustration above. The central microprocessor takes care of all the processes in the motor via the various I/O blocks such as the serial interface, differential transceiver (Multifunction I/O) and the motor driver sections.

Please notice that the MAC400, 402, 800, 1500 and MAC3000 have 2 supply voltages which offers the possibility to remove energy to the motor but keep having the control core active and thereby keeping position values and other dynamic parameters.

## 1.2

## Overall description

Basic Motor Type	Continuous Torque	Peak Torque	Power (cont.)	Nom. Speed	Flange	Total length
MAC50	0.11 Nm (15.58 oz-in)	0.32Nm (45.3 oz-in)	46 Watt	4000 RPM	NEMA23 57x57mm (2.3"x2.3")	111.2 mm, (4.38")
MAC95	0.22 Nm (31.15 oz-in)	0.62 Nm (87.8 oz-in)	92 Watt	4000 RPM	NEMA23 57x57mm (2.3"x2.3")	130.5 mm (5.13")
MAC140	0.32 Nm (45.32 oz-in)	0.9 Nm (127.45 oz-in)	134 Watt	4000 RPM	NEMA23 57x57mm (2.3"x2.3")	152.5 mm (6")
MAC141	0.48 Nm (67.97 oz-in)	1.59 Nm (225.16 oz-in)	134 Watt	2700 RPM	NEMA23 57x57mm (2.3"x2.3")	172.0 mm (6.77")
MAC400	1.27 Nm (180 oz-in)	3.8 Nm (538.1 oz-in)	400 Watt	3000 RPM	60x60mm (2.86"x2.86")	192.0 mm (7.56")
MAC402	1.27 Nm (180 oz-in)	3.8 Nm (538.1 oz-in)	400 Watt	3000 RPM	60x60mm (2.86"x2.86")	192.0 mm (7.56")
MAC800	2.38 Nm (337 oz-in)	7.2 Nm (1019.6 oz-in)	750 Watt	3000 RPM	80x80mm (3.14"x3.14")	175 mm (6.89")
MAC1500	4.78 Nm (676.91 oz-in)	14.33 Nm (2030.7 oz-in)	1500 Watt	3000 RPM	130x130mm (5.12"x5.12")	205.0 mm (8.07")
MAC3000	9.56 Nm (1353.8 oz-in)	28.7 Nm (4061.4 oz-in)	3000 Watt	3000 RPM	130x130mm (5.12"x5.12")	255 mm (10.04")

The MAC motor is available in 6 different sizes: MAC050, MAC95, MAC140, MAC141, MAC400, MAC800, MAC1500 and MAC3000 with continuous power ratings from 46W to 3000W. The basic functions and I/O features are the same for all models.

### 1.2.1 Basic modes/functions in the MAC motor

The MAC motor offers the following functions.

- **Passive mode.**  
The motor will be in a completely passive state but communication is active and internal registers can be set up.
- **Velocity mode.**  
The motor velocity can be controlled using MacTalk software or by sending commands via the serial interface.
- **Position mode**  
The motor position can be controlled using MacTalk or by sending position commands via the serial interface.
- **Gear mode**  
The position of the motor is controlled by the multifunction I/O, which is configured as input. Either a pulse and direction signal can be applied or a quadrature A and B signal from, for example, an incremental encoder.  
This mode is very powerful if the MAC motor is used to upgrade a step motor system or if the motor is used in electronic gear applications such as a flying saw where an external encoder tracks the position of a moving object.
- **Gear Follow Mode**  
Same mode as gear mode, except that the input pulses are not buffered so that control strictly follows the input pulses.

- **Analogue Velocity Mode**  
The motor velocity is controlled by a voltage applied at the  $\pm 10V$  analogue input. This mode can be used in several applications but typical applications include maintaining variable but constant speed in feeding mechanisms or as a slave driver in multi-axis systems with a master position controller for several axes.
- **Analogue Velocity (with deadband) Mode.**  
Same function as Analogue Velocity Mode but a deadband around zero is inserted. The deadband is  $\pm 600mV$ . This feature is useful if a potentiometer or similar device is used to control the speed of the motor, since the motor will be stationary if the input voltage is almost at zero.
- **Analogue Velocity/Gear Mode.**  
This mode is similar to Gear mode but it is possible to increase or decrease the position of the motor by adjusting the voltage applied to the  $\pm 10V$  input. A typical application is feeding mechanisms that require “on-the-fly” adjustment.
- **Velocity/Analogue torque Mode.**  
The motor torque is fully controlled by a voltage applied at the  $\pm 10V$  analogue input. This mode is useful if the motor is used for winding applications where a constant torque is required in the process. Another typical application is as a slave driver in multi-axis systems with a master position controller for several axes. The update frequency is 521 Hz. Use Analogue Torque (Direct) if a higher bandwidth is required.
- **Analogue Torque (Direct) Mode.**  
Same function as Analogue Torque mode but the update frequency is much higher (7812Hz). Please note that the top speed and acceleration are NOT controlled in this mode. Use Analogue Torque Mode if this limitation is required.
- **Analogue Gear Mode.**  
This mode is somewhat similar to *Gear mode* or *Analogue Velocity/Gear mode*. The position of the motor is controlled by the multifunction I/O, which is configured as input. Either a pulse and direction signal can be applied or a quadrature A and B signal from, for example, an incremental encoder.  
The gear ratio specified will determine the basic gear ratio between the applied pulses and the motor movement. The special feature in this mode is that the basic gear ratio can be changed  $\pm 5\%$  depending on the voltage applied to the analogue input.  $+10V$  will adjust the gear ratio  $+5\%$  higher and  $-10V$  will lower the gear ratio  $5\%$ . A typical application is feeding mechanisms that require “on-the-fly” adjustment.
- **Coil Mode.**  
Similar to gear mode but the position range can be limited in such a manner that the motor changes direction every time the upper limit is reached and also if the lower limit is reached. Both limits can be adjusted. The mode is intended to be used for controlling a wire/cable guider on a winding machine. The guide will follow the position of the coil driven by a “main motor” and using this mode it is possible to feed the wire in a very precise position regardless of the speed at which the “main motor” is running.

(continued next page)

## 1.2

## Overall description

---

- **Analogue bi position mode**  
The motor will move a certain distance or go to one of 2 positions depending on the voltage at the analogue input. The voltage at the analogue input will be seen as a digital signal, meaning either logic low or logic high.  
The distance or positions can be set up in 2 internal registers and saved permanently in the motor.
- **Analogue to position**  
The position of the motor will change proportionally with the voltage at the analogue input, between the zero position and a predefined position.  
A typical application could be controlling a valve position using a voltage or a current control signal.



## 1.2

## Overall description

All the motor families with subfeatures is shown below.

### MAC Motors feature overview



TT0933-02GB

Feature Type	Unbalanced async. serial interface For setup/sending commands	Balanced async. serial interface For setup/sending commands	±10V Analogue input For controlling speed/torque Also used for zero search	Pulse inputs Accepts pulse and direction or quadrature encoder signal	Pulse outputs 90 degree phase shifted outputs from internal encoder	Digital user inputs For control of program flow or motor start/stop	Digital user outputs For indicating the motor status or as output from the program	Ext. connector type	Protection class	Integrated brake
<b>MAC50,95,140,141-A1</b> Basic MAC motors IP42	5V TTL 19.2kbaud Full Duplex	RS422 (3) 19.2kbaud Full Duplex	✓	RS422 (3) 2.5Mhz or 150kHz (LP)	RS422 (3) 4096 cpr	No	Motor stat. 2 x NPN 25mA	AMP Molex JST	IP42	
<b>MAC50,95,140,141-A3</b> Basic MAC motors IP67	5V TTL 19.2kbaud Full Duplex	RS422 (3) 19.2kbaud Full Duplex	✓	RS422 (3) 2.5Mhz or 150kHz (LP)	RS422 (3) 4096 cpr	No	Motor stat. 2 x NPN 25mA	AMP Molex JST	IP67 (1)	
<b>MAC400-D2 (-D3)</b> Basic MAC motor IP55 (IP66)	5V TTL 19.2kbaud Full Duplex	RS422 (3) 19.2kbaud Full Duplex	✓	RS422 (3) 2.5Mhz or 150kHz (LP)	RS422 (3) 8192 cpr	No	Motor stat. 2 x NPN 25mA	AMP Molex JST	IP55 (IP66)	
<b>MAC400-D5 (-D6)</b> Basic MAC motor IP55 (IP66)	5V TTL 19.2kbaud Full Duplex	RS422 (3) 19.2kbaud Full Duplex	✓	RS422 (3) 2.5Mhz or 150kHz (LP)	RS422 (3) 8192 cpr	No	Motor stat. 2 x NPN 25mA	AMP Molex JST	IP55 (IP66)	✓
<b>MAC402-D2 (-D3)</b> Basic MAC motor IP55 (IP66)	5V TTL 19.2kbaud Full Duplex	RS422 (3) 19.2kbaud Full Duplex	✓	RS422 (3) 2.5Mhz or 150kHz (LP)	RS422 (3) 8192 cpr	No	Motor stat. 2 x NPN 25mA	AMP Molex JST	IP55 (IP66)	
<b>MAC402-D5 (-D6)</b> Basic MAC motor IP55 (IP66)	5V TTL 19.2kbaud Full Duplex	RS422 (3) 19.2kbaud Full Duplex	✓	RS422 (3) 2.5Mhz or 150kHz (LP)	RS422 (3) 8192 cpr	No	Motor stat. 2 x NPN 25mA	AMP Molex JST	IP55 (IP66)	✓
<b>MAC800-D2 (-D3)</b> Basic MAC motor IP55 (IP66)	5V TTL 19.2kbaud Full Duplex	RS422 (3) 19.2kbaud Full Duplex	✓	RS422 (3) 2.5Mhz or 150kHz (LP)	RS422 (3) 8000 cpr (8192)	No	Motor stat. 2 x NPN 25mA	AMP Molex JST	IP55 (IP66)	
<b>MAC800-D5 (-D6)</b> Basic MAC motor IP55 (IP66)	5V TTL 19.2kbaud Full Duplex	RS422 (3) 19.2kbaud Full Duplex	✓	RS422 (3) 2.5Mhz or 150kHz (LP)	RS422 (3) 8000 cpr (8192)	No	Motor stat. 2 x NPN 25mA	AMP Molex JST	IP55 (IP66)	✓
<b>MAC1500-D2 (-D3)</b> Basic MAC motor IP55 (IP66)	5V TTL 19.2kbaud Full Duplex	RS422 (3) 19.2kbaud Full Duplex	✓	RS422 (3) 2.5Mhz or 150kHz (LP)	RS422 (3) 8192 cpr	No	Motor stat. 2 x NPN 25mA	AMP Molex JST	IP55 (IP66)	
<b>MAC1500-D5 (-D6)</b> Basic MAC motor IP55 (IP66)	5V TTL 19.2kbaud Full Duplex	RS422 (3) 19.2kbaud Full Duplex	✓	RS422 (3) 2.5Mhz or 150kHz (LP)	RS422 (3) 8192 cpr	No	Motor stat. 2 x NPN 25mA	AMP Molex JST	IP55 (IP66)	✓
<b>MAC3000-D2 (-D3)</b> Basic MAC motor IP55 (IP66)	5V TTL 19.2kbaud Full Duplex	RS422 (3) 19.2kbaud Full Duplex	✓	RS422 (3) 2.5Mhz or 150kHz (LP)	RS422 (3) 8192 cpr	No	Motor stat. 2 x NPN 25mA	AMP Molex JST	IP55 (IP66)	
<b>MAC3000-D5 (-D6)</b> Basic MAC motor IP55 (IP66)	5V TTL 19.2kbaud Full Duplex	RS422 (3) 19.2kbaud Full Duplex	✓	RS422 (3) 2.5Mhz or 150kHz (LP)	RS422 (3) 8192 cpr	No	Motor stat. 2 x NPN 25mA	AMP Molex JST	IP55 (IP66)	✓

# 1.3 Expansion modules overview

JVL offers a wide variety of expansion modules to adapt the MAC motor to almost any kind of application. The expansion module is easily mounted inside the motor. Only one expansion module can be mounted.









The table below gives a brief overview of the features offered by the basic MAC motor and the features that are available in each expansion module.

	DSUB Connectors	Cable glands	M12 Connectors
<b>Basic modules</b> MAC00-B1, B2, B4 Connector module w/RS232 RS485 (non isolated) and LED's	MAC00-B1 	MAC00-B2 	MAC00-B4 
MAC00-B41 Connector module with Optical isolated RS232, Rs485 6 General digital I/O Support 2 multifunction I/O ports.	Not planned	Not planned	MAC00-B41 
<b>Industrial Ethernet modules</b> MAC00-EC4 EtherCAT® module MAC00-EI4 EthernetIP® module MAC00-EL4 Powerlink® module MAC00-EM4 Modbus TCP/IP® module MAC00-EP4 Profinet® module	 Not planned	Not planned	MAC00-EC4, EI4, EL4, EM4, EP4 
<b>Industrial Ethernet modules extended IO</b> MAC00-EC41 EtherCAT® module MAC00-EI41 EthernetIP® module MAC00-EL41 Powerlink® module MAC00-EM41 Modbus TCP/IP® module MAC00-EP41 Profinet® module	 Not planned	Not planned	MAC00-EC41, EI41, EL41, EM41, EP41 
<b>Wireless modules</b> MAC00-FB4 Wireless Bluetooth module MAC00-EZ4 Wireless Zigbee (IEEE 802.15.4) module MAC00-EW4 Wireless WLAN module	 Not planned	Not planned	MAC00-FB4, EZ4 and EW4 
<b>Fieldbus modules</b> MAC00-FC2, FC4 CANopen Supports DS402	 Not planned	MAC00-FC2 	MAC00-FC4 
MAC00-FD4 DeviceNet	 Not planned	Not planned	MAC00-FD4 
MAC00-FP2, FP4 Profibus DP 12Mbit with 6(4) Inputs and (2) outputs	 Not planned	MAC00-FP2 	MAC00-FP4 
<b>Multiaxis modules</b> MAC00-FS1, FS4 High speed serial RS485 Multiaxis 460kbaud	MAC00-FS1 	Not planned	MAC00-FS4 

TM033-02GB

# 1.3 Expansion modules overview

Expansion module overview (continued).

	DSUB Connectors	Cable glands	M12 Connectors
<p><b>Programmable modules</b></p> <p>MAC00-R1, R3, R4 Nano PLC with graphic programming interface 8 input and 4 outputs.</p>	<p>MAC00-R1</p> 	<p>MAC00-R3</p> 	<p>MAC00-R4</p> 
<p><b>Process control modules</b></p> <p>MAC00-P4 Process module 4-20mA input and output galvanic isolated. Only M12 Connectors</p>	<p>Not planned</p>	<p>Not planned</p>	<p>MAC00-P4</p> 
<p>MAC00-P5 Process module 4-20mA input and output galvanic isolated. Harting and M12 Connectors</p>	<p>Not planned</p>	<p>Not planned</p>	<p>MAC00-P5</p> 
<p><b>Rear plates</b></p> <p>MAC00-00/01/02 and MAC00-CS Rearplates with or without cable glandsConn. No electronic features included and no print at surface</p>	<p>MAC00-00</p> 	<p>MAC00-01</p> 	<p>MAC00-02</p> 
			<p>MAC00-CSxx</p> 

TT1176-03GB

# 1.3 Expansion modules overview

Below a detailed module overview also covering features, connectors etc. for each module.

## Expansion module overview.

TT1544-01GB

Feature \ Type	Unbalanced async. serial interface For setup/sending commands	Balanced async. serial interface For setup/sending commands	± 10V Analogue input For controlling speed/torque Also used for zero search	Pulse inputs Accepts pulse and direction or quadrature encoder signal	Pulse outputs 90 degree phase shifted outputs from internal encoder	Digital user inputs For control of program flow or motor start/stop	Digital user outputs For indicating the motor status or as output from the program	Ext. connector type	Protection class	Integrated brake
----------------	--	--	---	--	--	--	---	---------------------	------------------	------------------

### Basic modules

<b>MAC00-CS</b> (2) Conn. module w/cable glands No electronic features added	5V TTL 19.2kbaud Full Duplex	RS422 (3) 19.2kbaud Full Duplex	✓	RS422 (3) 2.5MHz or 150kHz (LP)	RS422 (3)	No	Motor stat. 2 x NPN 25mA	Cable Gland	IP67 (1)	
<b>MAC00-B1</b> Connector module w/DSUB connectors	RS232 19.2kbaud Full Duplex	RS422 (3) RS485 19.2k Full Duplex	✓	RS422 (3) 2.5MHz or 150kHz (LP)	RS422 (3)	No	Motor stat. PNP 10-32V 100mA	DSUB Plug- able	IP42	
<b>MAC00-B2</b> Connector module w/cable glands (2)	RS232 19.2kbaud Full Duplex	RS422 (3) RS485 19.2k Full Duplex	✓	RS422 (3) 2.5MHz or 150kHz (LP)	RS422 (3)	No	Motor stat. PNP 10-32V 100mA	Cable Gland	IP67 (1)	
<b>MAC00-B4</b> Connector module w/M12 connectors	RS232 19.2kbaud Full Duplex	RS422 (3) RS485 19.2k Full Duplex	✓	RS422 (3) 2.5MHz or 150kHz (LP)	RS422 (3)	No	Motor stat. PNP 10-32V 100mA	M12 Conn.	IP67 (1)	
<b>MAC00-B4I</b> Connector module w/M12 connectors	RS232 19.2kbaud Full Duplex	RS422 (3) RS485 19.2k Full Duplex	✓	RS422 (3) 2.5MHz or 150kHz (LP)	RS422 (3)	6 In/Out. (selectable) 5-30V	No	M12 Conn.	IP67 (1)	

### Industrial Ethernet modules

<b>MAC00-Ex4</b> Ethernet module Basic version	5V TTL 19.2kbaud Full Duplex	No	✓	No	No	1 Input Opto isol. 5-30V	1 Output PNP 10-32V 15mA	M12 Conn.	IP67 (1)	
<b>MAC00-Ex4I</b> Ethernet module Extended version	RS232 19.2kbaud Full Duplex	RS422 (3) RS485 19.2k Full Duplex	✓ x2	RS422 (3) 2.5MHz or 150kHz (LP)	RS422 (3)	4 Inputs Opto isol. 5-30V	2 Outputs PNP 10-32V 15mA	M12 Conn.	IP67 (1)	

### Wireless modules

<b>MAC00-FB4</b> Bluetooth module	RS232 19.2kbaud Full Duplex	RS422 (3) RS485 19.2k Full Duplex	✓	No	RS422 (3)	No	Motor stat. PNP 10-32V 100mA	M12 Conn.	IP67 (1)	
<b>MAC00-FZ4</b> Zigbee module - IEEE 802.15.4	RS232 19.2kbaud Full Duplex	RS422 (3) RS485 19.2k Full Duplex	✓	No	RS422 (3)	No	Motor stat. PNP 10-32V 100mA	M12 Conn.	IP67 (1)	
<b>MAC00-EW4</b> WLAN module	RS232 19.2kbaud Full Duplex	RS422 (3) RS485 19.2k Full Duplex	✓	No	RS422 (3)	No	Motor stat. PNP 10-32V 100mA	M12 Conn.	IP67 (1)	

### Fieldbus modules

<b>MAC00-FC2</b> CAN-Open module w/cable glands	RS232 19.2kbaud Full Duplex	No	✓	No	No	6 Inputs Opto isol. 5-30V	2 Outputs PNP 10-32V 25mA	Cable Gland	IP67 (1)	
<b>MAC00-FC4</b> CAN-Open module w/M12 connectors	RS232 19.2kbaud Full Duplex	No	✓ (4)	No	No	4 Inputs Opto isol. 5-30V (4)	2 Outputs PNP 10-32V 25mA (4)	M12 Conn.	IP67 (1)	
<b>MAC00-FD4</b> DeviceNet module w/M12 connectors	RS232 19.2kbaud Full Duplex	No	✓ (4)	No	No	4 Inputs Opto isol. 5-30V (4)	2 Outputs PNP 10-32V 25mA (4)	M12 Conn.	IP67 (1)	
<b>MAC00-FP2</b> Profibus DP w/cable glands	RS232 19.2kbaud Full Duplex	No	✓	No	No	6 Inputs Opto isol. 5-30V	2 Outputs PNP 10-32V 25mA	Cable Gland	IP67 (1)	
<b>MAC00-FP4</b> Profibus DP w/M12 connectors	RS232 19.2kbaud Full Duplex	No	✓ (4)	No	No	4 Inputs Opto isol. 5-30V (4)	2 Outputs PNP 10-32V 25mA (4)	M12 Conn.	IP67 (1)	

- 1) All these modules offer IP67 protection class. Please notice that the final protection class is limited by the actual motor used.
- 2) Can be ordered without cable (eg. MAC00-CS) or with cable in lengths of 2, 10 or 20 metres (eg. MAC-CS-10).
- 3) Either pulse input, pulse output or serial must be chosen. Not all of them at the same time.
- 4) Only a total of 4 I/O terminals are available.

Continued next page.

# 1.3 Expansion modules overview

Continued from last page

## Expansion module overview.

TT1175-02GB

Type \ Feature	Unbalanced async. serial interface For setup/sending commands	Balanced async. serial interface For setup/sending commands	± 10V Analogue input For controlling speed/torque Also used for zero search	Pulse inputs Accepts pulse and direction or quadrature encoder signal	Pulse outputs 90 degree phase shifted outputs from internal encoder	Digital user inputs For control of program flow or motor start/stop	Digital user outputs For indicating the motor status or as output from the program	Ext. connector type	Protection class	Integrated brake
<b>Multiaxis modules</b>										
<b>MAC00-FS1</b> RS485 High Speed. w/DSUB connectors. Multiaxis control	RS232 19.2kbaud Full Duplex	RS485 460kBaud Opto isol.	✓	RS422 (3) 2.5Mhz or 150kHz (LP)	RS422 (3)	4 Inputs Opto isol. 5-30V	2 Outputs PNP 10-32V 25mA	DSUB Plug- able	IP42	
<b>MAC00-FS4</b> RS485 High Speed. w/M12 connectors. Multiaxis control	RS232 19.2kbaud Full Duplex	RS485 460kBaud Opto isol.	✓	RS422 (3) 2.5Mhz or 150kHz (LP)	RS422 (3)	4 Inputs Opto isol. 5-30V	2 Outputs PNP 10-32V 25mA	M12 Conn.	IP67 (1)	
<b>Programmable modules</b>										
<b>MAC00-R1</b> Nano PLC w/ DSUB connect.	RS232 19.2kbaud Full Duplex	RS485 19.2kbaud Half Duplex	✓	No	No	8 Inputs Opto isol. 5-30V	4 Outputs PNP 10-32V 300mA	DSUB Plug- able	IP42	
<b>MAC00-R3</b> Nano PLC w/cable glands (2)	RS232 19.2kbaud Full Duplex	RS485 19.2kbaud HalfDuplex	✓	No	No	8 Inputs Opto isol. 5-30V	4 Outputs PNP 10-32V 300mA	Cable Gland	IP67 (1)	
<b>MAC00-R4</b> Nano PLC w/M12 circular connectors	RS232 19.2kbaud Full Duplex	RS485 19.2kbaud HalfDuplex	✓	No	No	8 Inputs Opto isol. 5-30V	4 Outputs PNP 10-32V 300mA	M12 Conn.	IP67 (1)	
<b>Process Control modules</b>										
<b>MAC00-P4</b> Process module 4-20mA w/ only M12	RS232 19.2kbaud Full Duplex	RS422 (3) RS485 19.2k Full Duplex	✓	RS422 (3) 2.5Mhz or 150kHz (LP)	RS422 (3)	3 Inputs NO iso. 5-30V	2 Outputs PNP 10-32V 100mA	M12 Conn.	IP67 (1)	
<b>MAC00-P5</b> Process module 4-20mA w/M12+Harting connectors	RS232 19.2kbaud Full Duplex	RS422 (3) RS485 19.2k Full Duplex	✓	RS422 (3) 2.5Mhz or 150kHz (LP)	RS422 (3)	No	1 Output PNP 10-32V 100mA	M12+ Hart. Conn.	IP67 (1)	

- 1) All these modules offer IP67 protection class. Please notice that the final protection class is limited by the actual motor used.
- 2) Can be ordered without cable (eg. MAC00-CS) or with cable in lengths of 2, 10 or 20 metres (eg. MAC-CS-10).
- 3) Either pulse input, pulse output or serial must be chosen. Not all of them at the same time.
- 4) Only a total of 4 I/O terminals are available.

# 1.4 Using MacTalk to setup the motor

**Setup save/open**  
The complete setup can be either saved or reloaded from a file using these buttons

**Startup mode**  
The basic functionality of the MAC motor is set up in this field.

**Profile Data**  
All the main parameters for controlling the motor behaviour are set up in this field.

**System control**  
Use these buttons to save data permanently, reset the motor etc.

**Error Handling**  
Use these fields to define error limits for the position range etc.

**Input/Outputs**  
The functionality of the I/O's is specified here.

**Motor status**  
This field shows the actual motor load, position and speed etc.

**Inputs**  
This field shows the actual supply voltage, the speed at the pulse input and the voltage at the analogue input.

**Errors**  
If a fatal error occurs, information will be displayed here.

**Zero Search**  
All the parameters regarding the position zero search can be specified here.

**Undervoltage handling**  
Determine what happens if the supply voltage gets too low..

MAC motor connection information Always shows if the motor is on line or not.

TT0914GB

## 1.4.1 MacTalk introduction

The MacTalk software is the main interface for setting up the MAC motor for a specific application.

The program offers the following features:

- Choice of the operating mode of the MAC motor.
- Changing main parameters such as speed, motor torque, *Zero search* type, etc.
- Monitoring the actual motor parameters in real time, such as motor load, supply voltage, voltage at the analogue input, etc.
- Changing protection limits such as position limits, maximum position error.
- Determine what should happen if the supply voltage gets too low.
- Saving all current parameters to disc.
- Restoring all parameters from disc.
- Saving all parameters permanently in the motor.
- Updating the motor firmware or MacTalk software from the internet or a file.

The main window of the program changes according to the selected mode, thus only showing the relevant parameters for operation in the selected mode.

The following pages describe the actual window for each mode and how the parameters affect the MAC motor operation.

## 1.4 Using MacTalk to setup the motor

---

### 1.4.2 Toolbar description

The toolbar at the top of the MacTalk window contains the most commonly used features.



#### Open

Opens a setup file from disc and downloads the setup to the motor. If no motor is connected, the setup is shown in MacTalk and can be edited and saved to disc again.

#### Save

Saves the actual setup from the motor to a file. If no motor is connected, the actual off-line settings (including module setups and program) will be saved.

#### Save in flash

The complete current setup of the basic motor will be saved permanently in the flash memory. If the motor is powered down or reset, the saved setup will be used.

#### Reset position

Resets the position counter to 0. The content of the position counter can be monitored in the right side of the main screen as "Actual position".

#### Clear errors

Clears all the errors (if any). Please note that if an error is still present, the motor will remain in the actual error state.

#### Reset motor

Reset the motor. Same as doing a power off / on operation.

#### Filter setup

Short-cut to the servo filter setup screen.

#### Stop motor

Stops the motor immediately using a controlled deceleration ramp and puts the motor into passive mode. If a program is present this is stopped as well.

This button shall be considered as a functional stop button and is available also by using the keyboard shortcut CTRL+F8.

Pressing the "STOP" button will immediately stop the motor by changing the currently running mode to "passive" using a fast controlled deceleration curve.

Using a MAC motor or a module that enables the user to execute RxP programs this execution is also halted to prevent the motor from starting up if a startup-mode is setup from a program.

**Warning! Do not consider this button as an appropriate Emergency stop. Always fit an Emergency stop circuitry to your motor setup.**

#### MacTalk Address

Only if more than one motor is connected to the same interface. The address specified in this field determines with which motor line communication is made.



# 1.4 Using MacTalk to setup the motor

## 1.4.3 Saving or opening a setup file to/from disc

The complete motor setup can be saved to disc or retrieved from disc and transferred to the motor. The setup files can be saved anywhere on the hard disc or to a floppy disc. Saving and opening a file over a network is also possible.

The setup files use the extension .MAC. By default, the setup files are saved in the same directory where MacTalk itself is also installed. Other directories can be selected.

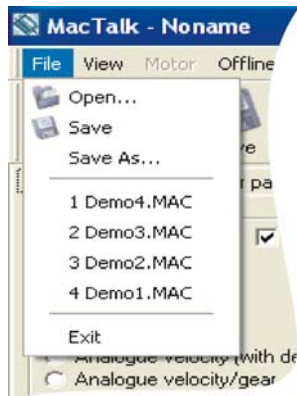

### From file to motor.

Use *Open* to select a file containing the desired motor setup. When opening the file the setup will simultaneously be sent to the motor.

Remember to use the *Save in flash* button if the setup must be permanently saved in the motor.

### From motor to file.

Use *Save* or *Save as* to save the actual setup in a motor as a setup file. Make sure that the motor is on-line with MacTalk, otherwise only the MacTalk default setup is saved.

In case where a motor is present and a disc file is opened the user is prompted for keeping the connection or going offline and displaying the file content. The following message box appears.

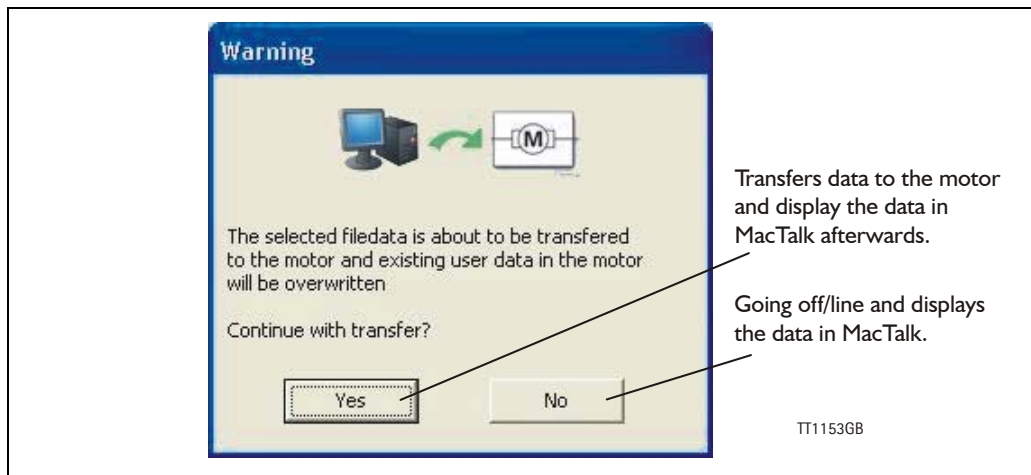

If the user decides to go offline the following textbox is presented.

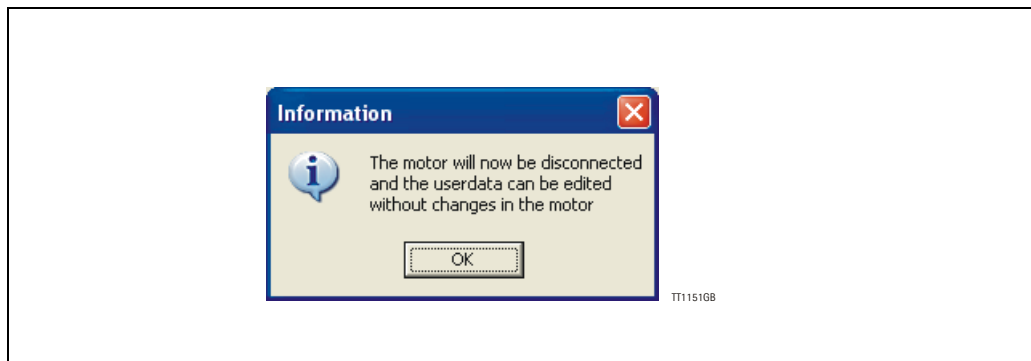



## 1.4 Using MacTalk to setup the motor

Pressing “OK” disconnects the motor from the PC application and all data can be edited without any interruption in the motor. The following MacTalk view is presented.

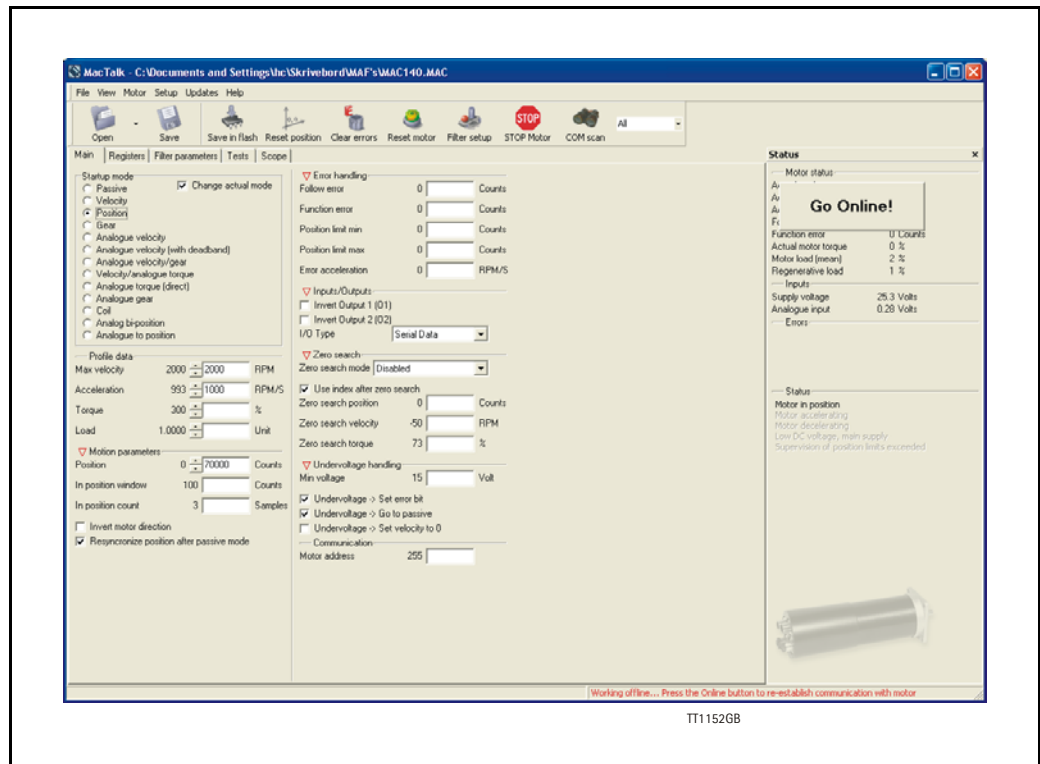

As seen in the bottom info line, the motor is disconnected and the filedata is currently present in MacTalk. To re-establish communication with the motor, simply press the “Go Online” button and if any data has been changed a warning box appears enabling the user to save current data before re-establishing communication with the motor as this will overwrite existing data in MacTalk.

If data is changed in MacTalk the user is warned that current data in MacTalk may be overwritten and needs to be saved. The following warning message box appears.



Choosing “No” will immediately upload all motor data, presing “Yes” will save all data in the open file.

# 1.4 Using MacTalk to setup the motor

## 1.4.4 Motor "TEST" function

When setting up a servo system its convenient to test the that the motor movement is stable and smooth.

For this purpose the TEST tab can be used.

At this tab its possible to setup the motor in position mode and define 2 positions where the motor can move cyclic in between. A delay between each motion can also be defined.

The speed and acceleration used during this process is the general parameters defined at the Main tab. All parameters can be changed dynamically during operation.

**1** Define position 1  
Define position 2

**2** Optionally: Define a delay (pause) at each position before continuing the movement.

**3** Set motor In position mode

**4** Finally push the **Start** button and the motor will start moving if the speed and other general parameters are set to proper values.

Select the «Tests» tab

Defines if motor movement should proceed before motor reach position or not. Recommended to keep this activated (default).

Illustration of the motor movement when the «Test» function is used.

Please notice that the movement is fully controlled by MacTalk.

If the communication cable is un-plugged the movement will stop at the last demanded position. Also some slight timing variations may exist depending at the windows operation system and which other application running at the PC at the same time.

**Important:** Make sure that no other communication takes place when using the Test function since it may interrupt the function of the test.



# 2.1

# Using Position mode

## 2.1.1 Position mode

Follow the description below to set up the MAC motor in Position mode. The MacTalk program is used to set up the motor initially. During normal operation, positioning commands can either be given through MacTalk or via one of the serial interfaces. The main window in MacTalk is as follows when position mode is selected.

**Reset Position**  
Use this button to reset the actual position counter

**Error Handling**  
Use these fields to define error limits for the position range etc.

**Input/Outputs**  
The functionality of the I/O's is specified here. In position mode, only Pulse Output or Serial Interface is relevant.

**Startup mode**  
Choose Position mode

**Profile Data**  
All the main parameters for the motion profile are setup in this field.

**Motion Parameters**  
The desired position and the "in position" window can be specified here.

**Motor status**  
This field shows the actual motor load, position and speed etc.

**Inputs**  
This field shows the actual supply voltage.

**Errors**  
If a fatal error occurs, information will be displayed here.

**Run Status**  
The motor status can be monitored here.

**Zero Search**  
All the parameters regarding the position zero search can be specified here. See the *Mechanical zero search* chapter.

MAC motor connection information  
Always shows if the motor is on line or not.

TT0926GB

- Startup Mode** Select position mode in this field.
- Reset Position** The counter which keeps track of the actual position can be reset using this button.
- Error Handling** Worst case limits for the position range can be set up here. Please consult the Error Handling chapter for details.
- Input/Outputs** The multifunction I/O terminals can be defined here. In Position mode these terminals can either work as a quadrature output from the internal encoder or as a serial RS422 interface for commands sent from a master controller. See also the *Multifunction I/O general description, page 113*.
- Motor Status** The actual mode, speed, position, position error, load torque, load current, regenerative energy (returned energy from the motor) can be monitored here.
- Inputs** The supply voltage can be measured here.

## 2.2

# Gear Mode

**Main parameters used in gear mode**

**Startup mode**  
Choose "Gear mode" or Gear (Follow)

**Profile Data**  
All these parameters can be used to limit the motion. For example the maximum torque or velocity.

**Gear factor**  
The ratio between the incoming pulses and the actual motor movement is specified here.

**Error Handling**  
Use these fields to define error limits for the maximum follow error etc.

**Input/Outputs**  
The I/O Type must be setup as pulse input. The input type must also be setup for the actual pulse type (quadrature or pulse/dir.).

**Motor status**  
This field shows the actual motor load, position and speed etc.

**Inputs**  
This field shows the actual supply voltage and velocity at pulse input

**Errors**  
If a fatal error occurs, information will be displayed here.

**Run Status**  
The motor status can be monitored here.

**Zero Search**  
Zero search can also be used. During zero search the gear mode will be set inactive. See also the Zero Search chapter.

TT0968GB

### 2.2.1

## Gear Mode - overall description

In gear mode, the motor follows a pulse signal applied to the Multifunction I/O terminals. The ratio between the incoming pulses and the motor movement can be adjusted to a desired value. A ratio from 1024:1 down to 1:1024 can be selected. Typically this mode is used if the MAC motor is incorporated into an application where movement needs to be synchronized with an external movement. Another typical application is the replacement of step motors, since the MAC motor in Gear Mode can work like a step motor using pulse and direction.

The following setup must be done to operate in gear mode (listed according to importance).

**Startup Mode** Select Gear Mode in this field.

**Gear Factor** This field defines the ratio between incoming pulses and the motor movement. If the preferred motor direction needs to be reversed, the sign in the "output" field must be inverted. Example: 1024 must be -1024 to reverse the direction of movement.

**Input/Outputs** The multifunction I/O terminals must be set to "pulse input" since gear mode uses the incoming pulses at this input to control the motor movement. Also the "Input type" must be selected. Choose "Quadrature" if an incremental encoder is connected or "pulse-direction" if it is a step motor signal. See also *Multifunction I/O general description, page 113*.

(Continued next page)

---

<b>Profile data</b>	<p>In gear mode, motor movement is fundamentally controlled from the external signal source, but via the 4 parameters specified in “Profile data” field it is possible to add limitations to speed, etc.</p> <p>“Velocity” The velocity field can be used to limit the maximum speed of the motor. Example - if an external encoder is producing a frequency which theoretically should give a MAC motor speed of 10000 RPM, the speed can be limited to 4000 RPM (max. allowed speed for the MAC). The motor will be unstable and go in error within some time since it is not able to run at 10000 RPM. Note that no pulses are lost if the velocity is limited. They are simply remembered and used when the input frequency falls to a level at which the motor is able to follow.</p> <p>“Acceleration” The acceleration parameter can be useful in systems in which the signal source instantaneously applies a high frequency without any acceleration. Under this condition, the MAC motor will take care of making a controlled acceleration and deceleration. Note that no pulses are lost if the acceleration is limited. They are simply remembered and used when motor velocity reaches a level corresponding to the input frequency.</p> <p>“Torque” The maximum torque can be limited in the range 0-300%. 300% corresponds to the rated peak torque of the MAC motor used.</p> <p>“Load” The Load parameter is the overall gain in the position/velocity filter and ensures that the motor is stable with the actual mechanical inertia used in the application. See also the filter setup chapter for further details.</p>
<b>Error Handling</b>	Worst case limits for the position range and follow error (maximum position error) can be set up here. Please consult the Error Handling chapter for details.
<b>Motor Status</b>	The actual mode, speed, position, position error, load torque, load current, regenerative energy (energy returned from the motor) can be monitored here.
<b>Inputs</b>	The supply voltage can be measured here.
<b>Zero search</b>	In typical gear mode applications the motor is moving relatively without any absolute zero point, but for applications that require a specific mechanical zero position, the general <i>Zero search</i> in the MAC motor can be used. Please consult the chapter <i>Mechanical Zero search</i> , page 32.

## 2.2

## Gear Mode

### Example 1:

#### Encoder (quadrature) input.

An external encoder feeds the MAC motor. The I/O type is set to “Pulse input“ and “Input type” is set to “Quadrature” in order to decode the encoder signal. The encoder is connected to the A and B terminals (Multifunction I/O’s). See also *Multifunction I/O used as pulse inputs, page 114*.

The resolution of the external encoder is 500 ppr. The MAC motors have MAC50-141 = 1024 ppr. MAC800 = 2000 ppr. MAC400, MAC1500 and MAC3000 = 2048 ppr.

If this application requires that the MAC motor rotates 1 rev. each time the external encoder has rotated 1 rev., the *Input* parameter is set to 500 (external encoder) and the *Output* parameter is set to 1024 or 2000. Now the ratio between the external encoder and the MAC motor will be 1:1. Ensure the “Profile data” is set to proper values in order not to limit motor operation unintentionally.

### Example 2:

#### Pulse and direction input.

A step motor system is replaced by a MAC motor, meaning that the MAC motor receives a pulse and direction signal which is a very common signal format in step motor applications.

The I/O type is set to “Pulse input“ and “Input type” is set to “Pulse-direction” in order to decode the input signal. The pulse signal is connected to the A terminals (Multifunction I/O) and the direction signal is connected to the B terminals (Multifunction I/O’s).

See also *Multifunction I/O used as pulse inputs, page 114*.

The MAC motor is replacing a step motor system with 400 steps per revolution, which means that when the pulse source produce 400 pulses, it expects the MAC motor to rotate one revolution.

The MAC motors have MAC50-141 = 1024 ppr. MAC800 = 2000 ppr (MAC800) and MAC400, MAC1500 and MAC3000 = 2048 ppr. If this application requires that the MAC motor rotates 1 revolution each time 400 pulses are received, the *Input* parameter is set to 800 since the MAC motor detects on both the rising and falling edge of the input signal.

The *Output* parameter is set to 4096 or 8000 since the number of counts (edges) on the internal encoder is 4096 or 8000. Now the MAC motor will move 1 revolution if 400 pulses is applied to the pulse input. Ensure the “Profile data” is set to proper values in order not to limit motor operation unintentionally. The following table can be used as guide for setting up typical gear ratios:

Pulse and direction gear ratio setup - “Commonly used ratios”			
Applied number of pulses per MAC motor revolution.	Input register	Output register	
		MAC50-141	MAC800
200	400	4096	8000
400	800	4096	8000
500	1000	4096	8000
800	1600	4096	8000
1000	2000	4096	8000
2000	4000	4096	8000
4096 (Same as motor resolution)	8192	4096	8000

## 2.3

# Coil Mode

### 2.3.1 Coil Mode - overall description

The Coil Mode is similar to gear mode but the position range can be limited in such a manner that the motor changes direction every time 2 predefined limits (upper and lower) are reached. Both limits are fully adjustable. The mode is intended to be used for controlling a wire/cable guider on a winding machine. The guide will follow the position of the coil driven by a “main motor” like it was mechanically connected by a transmission, and by using this mode it is possible to steer the wire to the desired position at the coil, also when the “main motor” changes speed. Since Coil Mode is very similar to Gear mode, it is recommended that the gear mode setup instructions are followed before using the additional features described in this section. See *Gear Mode*, page 21.

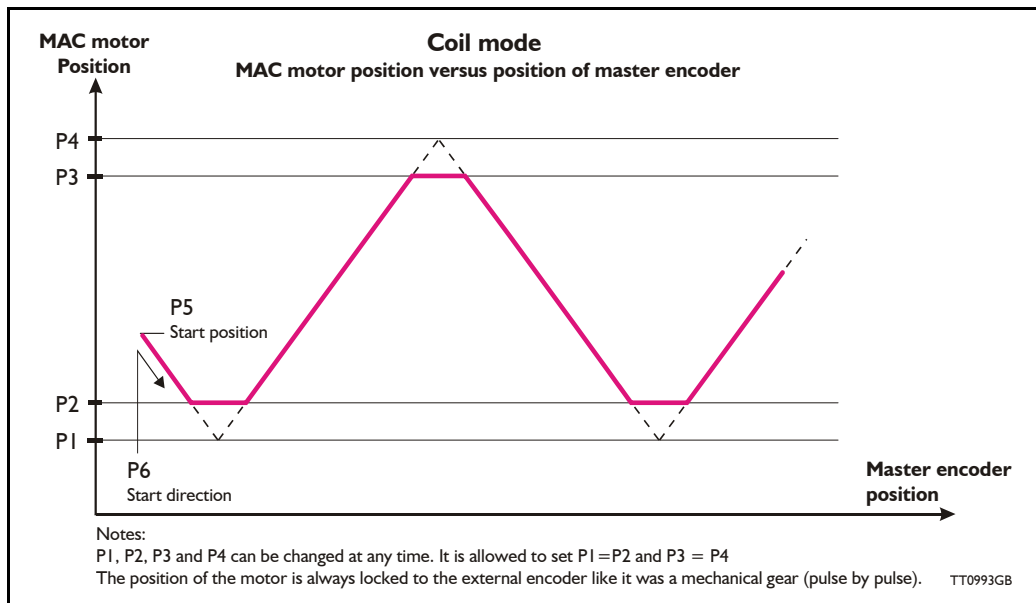

When coiling a thick thread compared to the coil, and the number of windings per layer are few, it is preferable to stop the traverse motion while one winding is coiled at the top of the previous winding at the edges. Therefore the edges can be cut off at the positions given by registers P2 and P3, as shown in the illustration above.

When starting a new coil, you must specify the starting position, and the starting direction of the MAC motor to achieve repeatability. The starting position, related to the basic function shown in the illustration above, is given by the value of register P5. The starting direction is given by the value of register P6, which value must be +1 or -1 for either a positive or negative direction.

A typical setup could be:

- P1 = 10000 Left position limit of basic function
- P2 = 12000 Left cut off position
- P3 = 58000 Right cut off position
- P4 = 60000 Right position limit of basic function
- P5 = 12000 Starting position ( at left edge )
- P6 = 1 Start traversing right (positive direction)

Positioning at the start position is initiated by setting the analogue input, (AIN), high. When setting this input low, the MacMotor will resume normal coiling function.



## 2.3

# Coil Mode

---

The rules for setting up P1 ... P6 are:

P1 <= P2 <= P3 <= P4

P1 <= P5 <= P4

P6 = +1 or -1

### 2.3.2 The gear ratio in coil mode

The gearing ratio must be specified in the exact same manner as GEAR mode, using the Input and Output registers. See *Gear Mode - overall description, page 21*.

### 2.3.3 Initiating Zero search in coil mode

The MAC motor can be set up to make an initiating *Zero search* at power up. When using the sensor *Zero search* modes, the *Zero search* function uses the analogue input as zero sensor input and the coiling function uses the signal to sense the 'go to start position command'. Still the two signals can be coupled in parallel if the *Zero search* sensor is activated away from normal working area (Normally open).

In conjunction with the above setup for registers P1 ... P6, the setup for the *Zero search* could therefore be:

*Zero search* type: "Sensor 1"

*Zero search* velocity: -100

*Zero search* position: -2000

Start mode: Coil Mode

Having ended the power-up *Zero search*, you must give the MAC motor an initial start-position command before starting the first coil process.

### 2.3.4 Filter setup in coil mode

Recommended filter setting for this application (using the filter selector).

Please note that the filter setting can also depend on other factors such as the inertia, friction etc. in the actual system.

Current filter: Medium or high.

Position filter: x-y coordinate = 3, 3 (fast, almost hard)

Follow error type: Static, degree = 75%

Remember load factor to finely adjust the LOAD factor (MacTalk main tab).

Other settings, ( recommended ):

- Max velocity: Set limit higher than the normal speed used
- Acceleration: Set high value (example 300000 RPM/sec)
- Torque: 300%
- Gear factor: Set value
- Follow error: 0
- Function error: 0

## 2.3

# Coil Mode

### 2.3.5 Register overview in MacTalk

The following screen is shown in MacTalk when selecting Coil Mode.

**Main parameters used in coil mode**

**Startup mode**  
Choose “Coil mode”

**Profile Data**  
All these parameters can be used to limit the motion. For example the maximum torque or velocity.

**Coil mode parameters**  
Set P1 to P6 in this field according to the description in this chapter.

**Gear factor**  
The ratio between the incoming pulses and the actual motor movement is specified here.

TTI127GB

The general setup, such as selecting maximum velocity, gear ratio and input type setup, is similar to Gear Mode. Only the Coil Mode parameters differ from Gear Mode. For details of the overall setup, please See *Gear Mode*, page 21.

## 2.4

# Analogue bi position mode

---

### 2.4.1 Analogue Bi-position Mode - overall description

For primitive positioning purposes, the basic MAC motor offers the Analogue bi-position mode. The Analogue bi-position mode offers:

The motor will move a certain distance or go to one of 2 positions depending on the voltage at the analogue input. The voltage at the analogue input will be seen as a digital signal meaning either logic low or logic high.

The distance or positions can be setup in 2 internal registers and saved permanently in the motor.

Concerning the trigger level at the input and how to change please consult *Analogue input, page 110*

## 2.5 Analogue to position mode

### 2.5.1 “Analogue to position” Mode - overall description

In Analogue to position mode, the motor follows an analogue input voltage applied to the analogue input (AIN / AIN1).

The distance that the motor is moving as a function of full voltage (+10V or -10V) is defined by the “Full range” register expressed in encoder counts.

The absolute position when 0V is applied is defined by the “Offset” register.

For filtering away any noise at the input signal the “Hysteresis” register can be used.

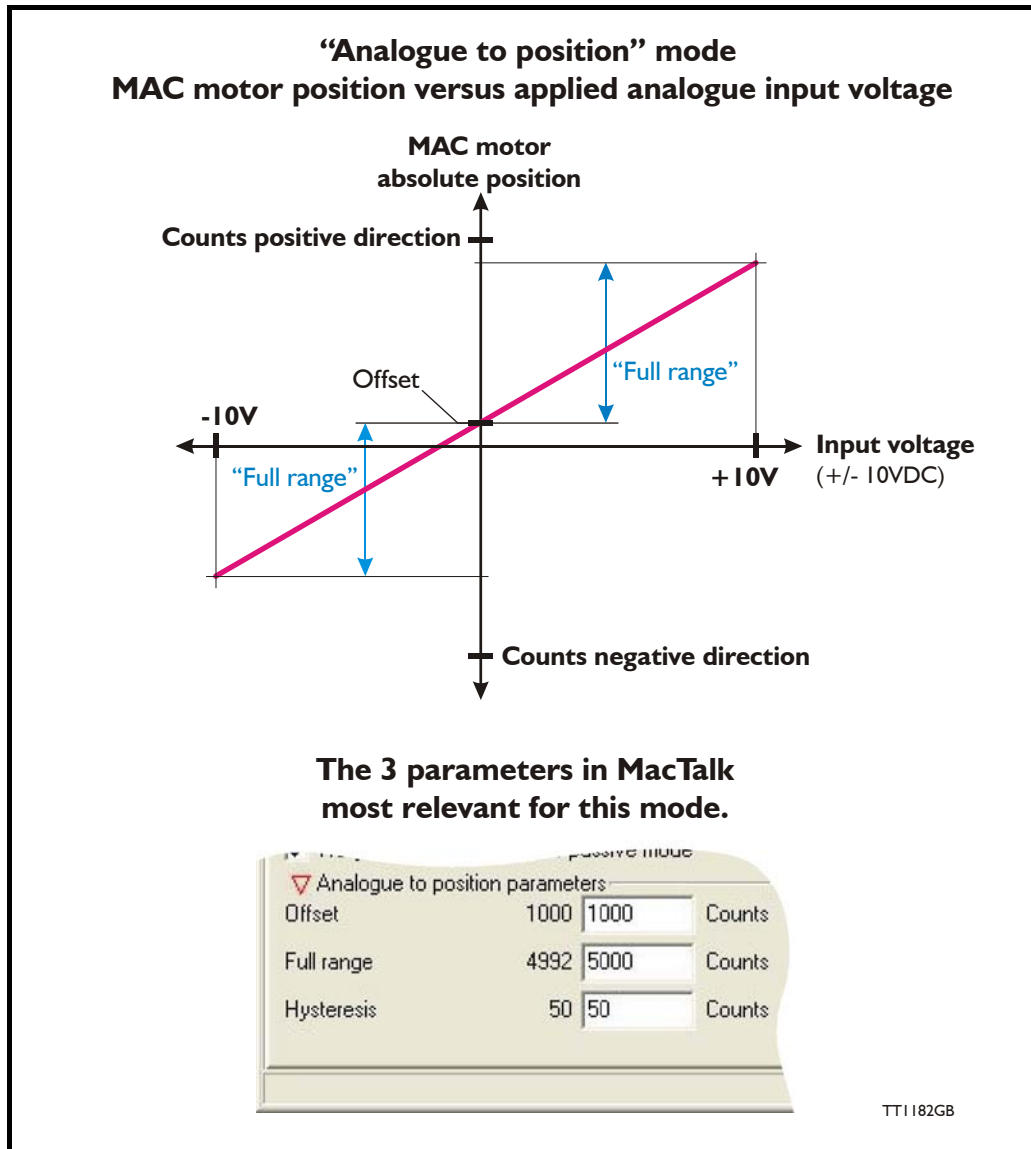

## 2.5 Analogue to position mode

**Main parameters used in analogue to position mode**

**Startup mode**  
Choose "Analogue to position"

**Profile Data**  
All these parameters can be used to limit the motion. For example the maximum torque or velocity.

**Analogue to position setup**  
The desired position range, optional position offset and hysteresis is specified here.

**Error Handling**  
Use these fields to define error limits for the maximum follow error etc.

**Motor status**  
This field shows the actual motor load, position and speed etc.

**Inputs**  
This field shows the actual supply voltage and velocity at pulse input

**Errors**  
If a fatal error occurs, information will be displayed here.

**Run Status**  
The motor status can be monitored here.

**Zero Search**  
Zero search can also be used. During zero search the "Analogue to position" mode will be set inactive. See also the [Zero Search](#) chapter.

TT1181GB

The following setup parameters can be necessary or convenient to use in the "Analogue to position" mode.

**Startup Mode** Select "Analogue to Position" Mode in this field.

### Analogue to position parameters

This area is used to define the range and offset for the motor movement versus the analogue input (see curve on the previous page).

### Profile data

In this mode, the motor movement is fundamentally controlled from the external signal source, but via the 4 parameters specified in "Profile data" field it is possible to add limitations to speed, etc.

#### "Velocity"

The velocity field can be used to limit the maximum speed of the motor. Example - if an external encoder is producing a frequency which theoretically should give a MAC motor speed of 10000 RPM, the speed can be limited to 4000 RPM (max. allowed speed for the MAC). The motor will be unstable and go in error in a short time since it is not able to run at 10000 RPM. Note that no pulses are lost if the velocity is limited. They are simply remembered and used when the input frequency falls to a level at which the motor is able to follow.

(Continued next page)

## 2.5 Analogue to position mode

---

### “Acceleration”

The acceleration parameter can be useful in systems in which the voltage source instantaneously applies a rapid change without any ramp acceleration. Under this condition, the MAC motor will take care of making a controlled acceleration and deceleration. Note that no position information is lost if the acceleration is limited. The target position is always respected and used.

### “Torque”

The maximum torque can be limited in the range 0-300%. 300% corresponds to the rated peak torque of the MAC motor used.

### “Load”

The Load parameter is the overall gain in the position/velocity filter and ensures that the motor is stable with the actual mechanical inertia used in the application. See also the chapter *Servo filter adjustment*, page 53 for further details.

<b>Error Handling</b>	Worst case limits for the position range and follow error (maximum position error) can be set up here. Please consult the chapter <i>Error messages and error handling</i> , page 40 for details.
<b>Motor Status</b>	The actual mode, speed, position, position error, load torque, load current, regenerative energy (energy returned from the motor) can be monitored here.
<b>Inputs</b>	The supply voltage and actual voltage at the analog input can be measured here.
<b>Zero search</b>	In typical gear mode applications the motor is moving relatively without any absolute zero point but for applications that require a specific mechanical zero position, the general <i>Zero search</i> in the MAC motor can be used. Please consult the chapter <i>Mechanical Zero search</i> , page 32.

## 2.5 Analogue to position mode

**Example:**

A voltage source feeds the MAC140 motor that has 4096 counts per revolution (standard).

The desired working range is 5000 counts (approx. one revolution) and it is desired to have an offset from the zero point where the *Zero search* was done of 1000 counts (1/4 motor revolution).

Therefore the “Offset” register is set to 1000 counts and the “Full range” register is set to 5000 counts. Please notice that a bit rounding is done since the analogue input and also the motor encoder has a limited resolution.

In addition its desired to have a certain filtering at the input meaning that the motor should not move unless the input voltage changes more than what correspond to a movement of 50 counts.

As a result the “Hysteresis” register is set to 50 counts.

Ensure the “Profile data” containing motor “Velocity”, “Acceleration” etc. is set to proper values in order not to limit motor operation unintentionally.

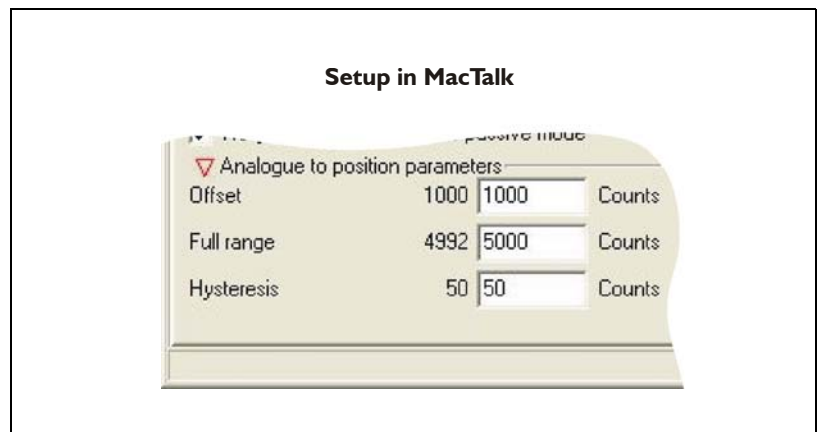

## 2.6

# Mechanical Zero search

### 2.6.1 Mechanical Zero search modes

In all positioning systems there is a requirement to be able to find a mechanical zero position after the system is powered up or at specific times during operation. For this purpose the MAC motor offers 5 different *Zero search* modes which can be selected in the MacTalk main window or by sending a command at one of the serial interfaces.

The 5 different *Zero search* modes can in addition be selected to be started automatically after power up of the motor or done by sending a command during normal operation to the motor.

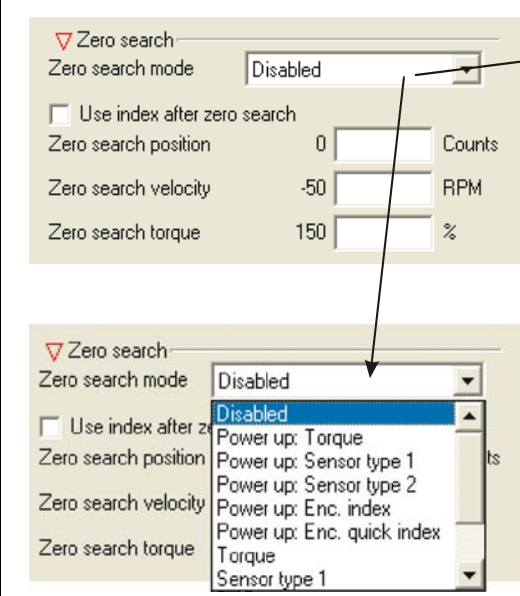

Select the Zero search mode using this field. The selected format will be used as follows :

- Immediately after the motor is powered up (only the “Power up ...” Formats)
- If a search is initiated via the serial interface or
- From an expansion module (MAC00-R1, R4, -FP4, EC4 etc.).

Please note that the 3 formats for “Power up” Zero search must not be selected if an expansion module is used (MAC00-R1, R3 or FP2). If an automatic zero search after “Power up” is required when using one of these modules, the function must be enabled on the product tab for the actual module. (See also the chapters describing the expansion modules)

TT0919GB

The menu offers 11 choices:

Type	Availability		Precision	Ext. sensor needed
	MAC050-141	MAC400-3000		
Disabled (no <i>Zero search</i> )	Yes	Yes	-	-
Power up: Torque	Yes	Yes	Low	No
Power up: Sensor type 1	Yes	Yes	Medium	Yes
Power up: Sensor type 2	Yes	Yes	High	Yes
Power up: Enc. Index	No	Yes	High	No
Power up: Enc. quick index	No	Yes	Medium	No
Torque	Yes	Yes	Low	No
Sensor type 1	Yes	Yes	Medium	Yes
Sensor type 2	Yes	Yes	High	Yes
Enc. Index	No	Yes	High	No
Enc. quick index	No	Yes	Medium	No

### 2.6.2 Overall Zero search mode descriptions

- Disabled (default)** The *Zero search* is disabled.
- Power up: Torque** Similar to “Torque” but the *Zero search* will automatically be started after power up.
- Power up: Sensor type 1** Similar to “Sensor type 1” but the *Zero search* will automatically be started after power up.



## 2.6

## Mechanical Zero search

---

<b>Power up: Sensor type 2</b>	Similar to “Sensor type 2” but the <i>Zero search</i> will automatically be started after power up.
<b>Power up: Enc. Index</b>	Similar to “Enc. Index” but the <i>Zero search</i> will automatically be started after power up.
<b>Power up: Enc. quick index</b>	Similar to “Enc. Index” but the <i>Zero search</i> will automatically be started after power up.
<b>Torque</b>	The <i>Zero search</i> will start searching for Zero until a mechanical “collision” occurs. The point at which the motor torque is equal to the specified value of the <i>Zero search</i> torque is defined as the zero position.
<b>Sensor type 1</b>	The <i>Zero search</i> function will start seeking for Zero until an external sensor is activated. The point at which the sensor is activated is defined as zero. The active sensor level can be changed by changing the sign at the value specified in the <i>Zero search torque</i> field.
<b>Sensor type 2</b>	Like above (Sensor type 1) but after the sensor is activated the direction of movement is reversed and the point at which the sensor is disabled is defined as zero.
<b>Enc. Index</b>	The <i>Zero search</i> function will move exactly 1.5 motor revolution and detect where the internal encoder index pulse is detected. The position where the index pulse was found is defined as zero. This <i>Zero search</i> mode is very much similar to <i>Enc. quick index</i> but is much more precise and take some seconds.
<b>Enc. quick index</b>	The <i>Zero search</i> function will move the motor until the index position is detected. Then it reverses back to this position. The position where the index was detected is defined as zero. This <i>Zero search</i> mode is very similar to <i>Enc. index</i> but is much faster and is not as precise

The following sections explain in detail the functionality of the 5 fundamental *Zero search* modes.

### 2.6.3 Starting a Zero search

If the *Zero search* mode is set to *Disabled*, no *Zero search* is done at any time.

If one of the 5 modes *Power up: Torque*, *Sensor type 1*, *Sensor type 2*, *Enc. index* or *Enc. quick index* is selected, the respective *Zero search* mode will be executed every time the MAC motor is powered up.

The *Zero search* can also be initiated by sending a specific command via one of the serial interfaces — please consult the technical manual (LB0048-xx) for more details or see the individual detailed *Zero search* descriptions in the next pages.

## 2.6

# Mechanical Zero search

### 2.6.4 "Torque" Zero search

Torque Zero search is carried out according to the following illustration.

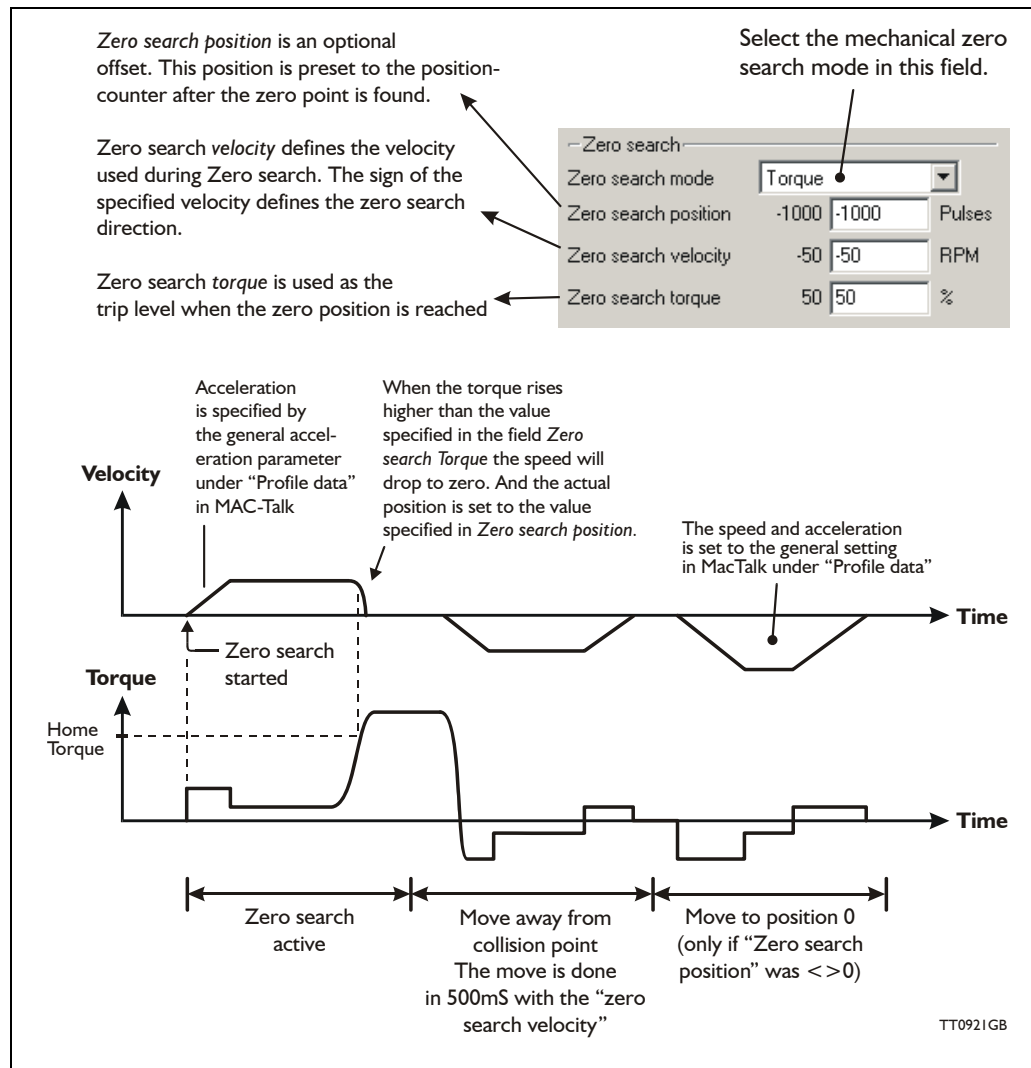

The Zero search method using a torque as a reference is a cheap, simple way to find the mechanical zero position, but please be aware of following critical points.

- Make sure that the Zero search torque is set to a proper value higher than the mechanical friction in the system in order to avoid a faulty zero point being found. It is a good idea to let the motor run in velocity mode with the same velocity and observe what the actual motor torque is. This value can be observed in the status area in the right side of the main window. Set the Zero search torque to a value 10-20% higher than the actual torque observed during this procedure.
- To improve the repeatability precision of the zero point make sure that the mechanical "collision" point is as stiff and well-defined as possible.

## 2.6 Mechanical Zero search

### 2.6.5 “Sensor type 1” Zero search

Sensor type 1 Zero search is carried out according to the following illustration.

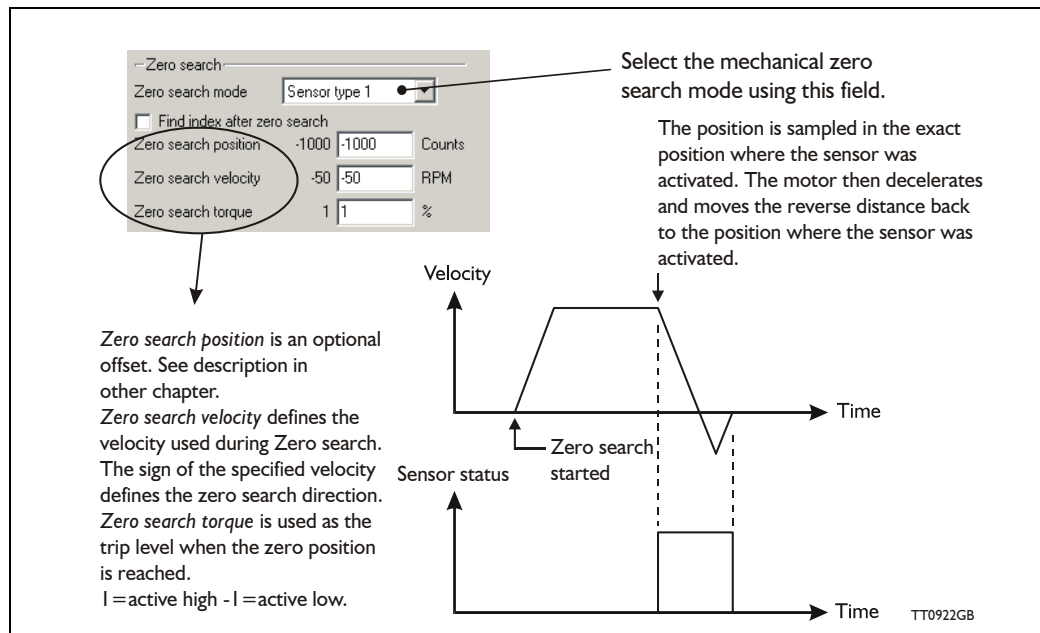

The Zero sensor must be connected to the analogue input (AIN), which during Zero search functions as a digital input. For connection information and electrical specification, see *Analogue input*, page 110.

### 2.6.6 “Sensor type 2” Zero search

Sensor type 2 Zero search is carried out according to the following illustration.

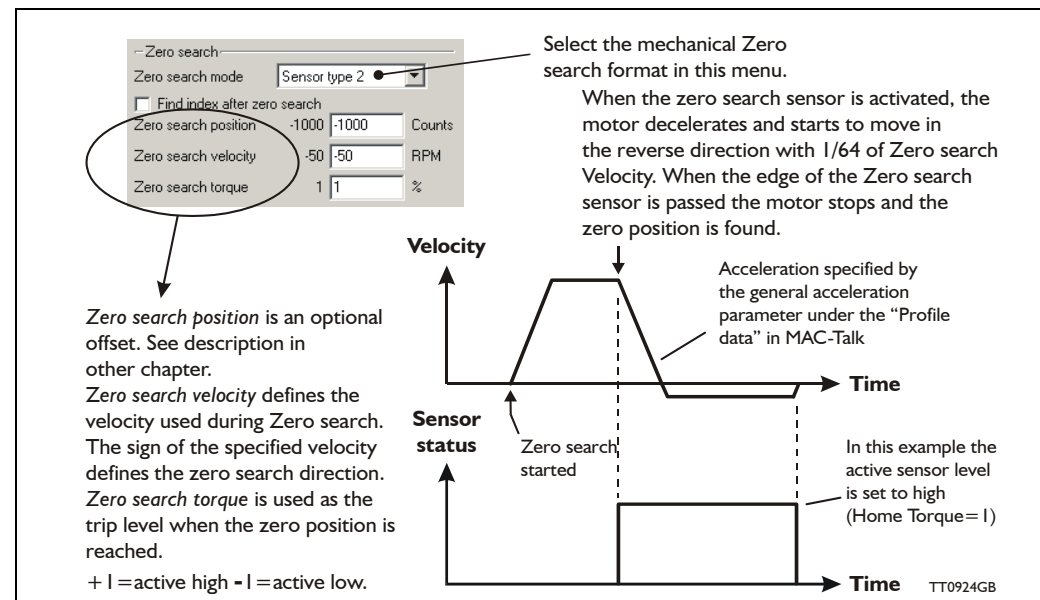

The Zero sensor must be connected to the analogue input (AIN), which during Zero search, functions as a digital input. For connection information and electrical specification, see *Analogue input*, page 110.

### 2.6.7 “Enc. Index” Zero search

The internal optical encoder in the MAC motor also contains a so called index pulse which is a very short (4 counts) distance which is only present (active) one time per motor revolution. For applications where the working range is always less or equal one revolution this pulse can be used as the mechanical zero avoiding having any external sensors involved which simplify the mechanics and the cabling.

This *Zero search* mode is similar to the “Enc. Quick Index” *Zero search* mode except that its done slower but also with a much better precision since the index pulse is sampled with a tolerance of  $\pm 100\mu\text{s}$  but will need a few seconds to do depending on the *Zero search* speed and overall acceleration used.

When the “Enc. Index” *Zero search* is carried out the motor will be moving exactly 1.5 revolution in total. Then a pause of 1.3 seconds is used to stabilize the motor position and do various calculations.

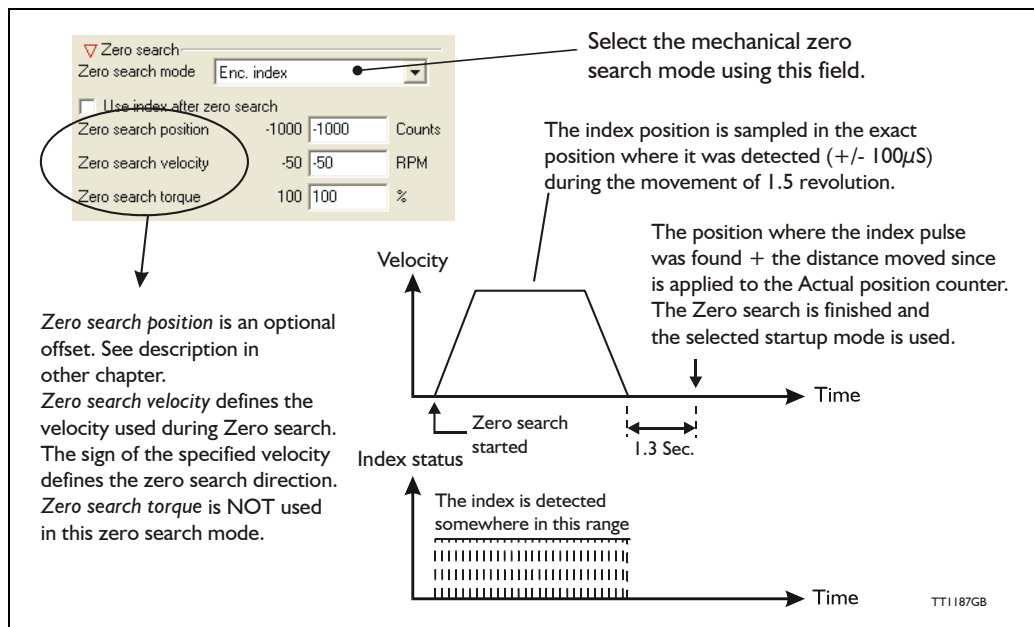

### 2.6.8 Configuration via motor registers.

When the configuration is done by channels other than MacTalk such as Ethernet, Profibus, CAN-open etc. or just a simple interface connection to the basic motor the following description must be followed.

#### Start the “Enc. Index” Zero search:

Write the decimal value 25 into the MODE\_REG (register 2). This will immediately start the *Zero search*. The value is expressed in 32 bits unsigned.

#### Set the Zero search velocity:

Write the velocity value into the register V\_HOME (register 40). Notice that the sign will determine the *Zero search* direction.

A velocity expressed as 100 RPM must be written as 277 (1 RPM = 2.77). The value is expressed in 32 bits signed.

Concerning setting of *Zero search* position see *Making a Zero point offset*, page 38

## 2.6

# Mechanical Zero search

Only MAC400 to 3000

### 2.6.9 “Enc. Quick Index” Zero search

The internal optical encoder in the MAC motor also contains a so called index pulse which is a very short (4 counts) distance which is only present (active) one time per motor revolution.

For applications where the working range is always less or equal one revolution this pulse can be used as the mechanical zero avoiding having any external sensors involved which simplify the mechanics and the cabling.

This *Zero search* mode is similar to the “Enc. Index” *Zero search* mode except that its done much faster but also with a larger tolerance since the index pulse is sampled with a tolerance of  $\pm 1.3\text{mS}$  but without any delays involved in the *Zero search*.

When “Enc. Quick Index” *Zero search* is carried out the motor will start moving until the index pulse is met. The motor will then decelerate and move backward to the point where the index pulse was detected.

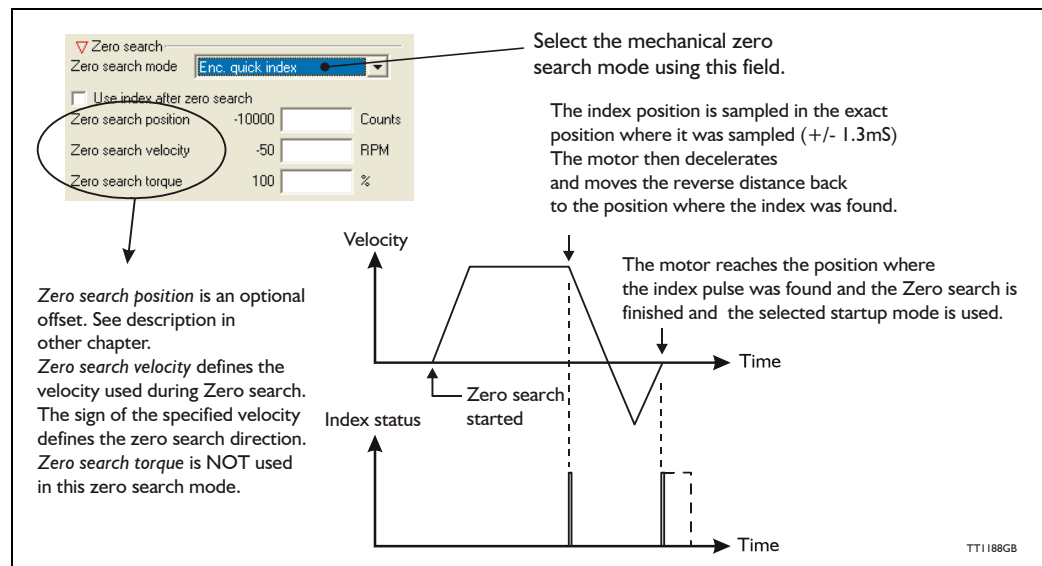

### 2.6.10 Configuration via motor registers.

When the configuration is done by channels other than MacTalk such as Ethernet, Profibus, CAN-open etc. or just a simple interface connection to the basic motor the following description must be followed.

#### Start the “Enc. Quick Index” Zero search:

Write the decimal value 26 into the `MODE_REG` (register 2). This will immediately start the Zero search. The value is expressed in 32 bits unsigned.

#### Set the Zero search velocity:

Write the velocity value into the register `V_HOME` (register 40). Notice that the sign will determine the Zero search direction.

A velocity expressed as 100 RPM must be written as 277 (1 RPM = 2.77). The value is expressed in 32 bits signed.

Concerning setting of Zero search position see *Making a Zero point offset*, page 38

## 2.6

# Mechanical Zero search

### 2.6.11 Making a Zero point offset

Common for all the *Zero search* modes, it can optionally be chosen to define the zero-point as a value other than zero (position 0).

When is it useful to use the zero point offset?

- If it is desired that the position interval under normal operation is always convenient positive values from 0 to +n, instead of a mixture of negative and positive values. This can occur if the zero point sensor is placed a long distance away from the normal positioning interval or inside the normal positioning interval.
- If an automatic move to an initial position is desired after a power-up *Zero search*.

The offset value must be specified in the “*Zero search position*” field.

The total *Zero search* will be performed in following order.

1. The *Zero search* is started either automatically (power up) or initiated by command from the interface or via an expansion module.
2. The basic *Zero search* is completed and the position counter is set to the value specified in the *Zero search position* field.
3. If the *Zero search* position value is different from position, the motor will now move to position 0.
4. The *Zero search* is now completed and the motor will switch to normal operation which means the mode selected in the “Startup mode” field in the main window.

The illustration below shows the complete cycle.

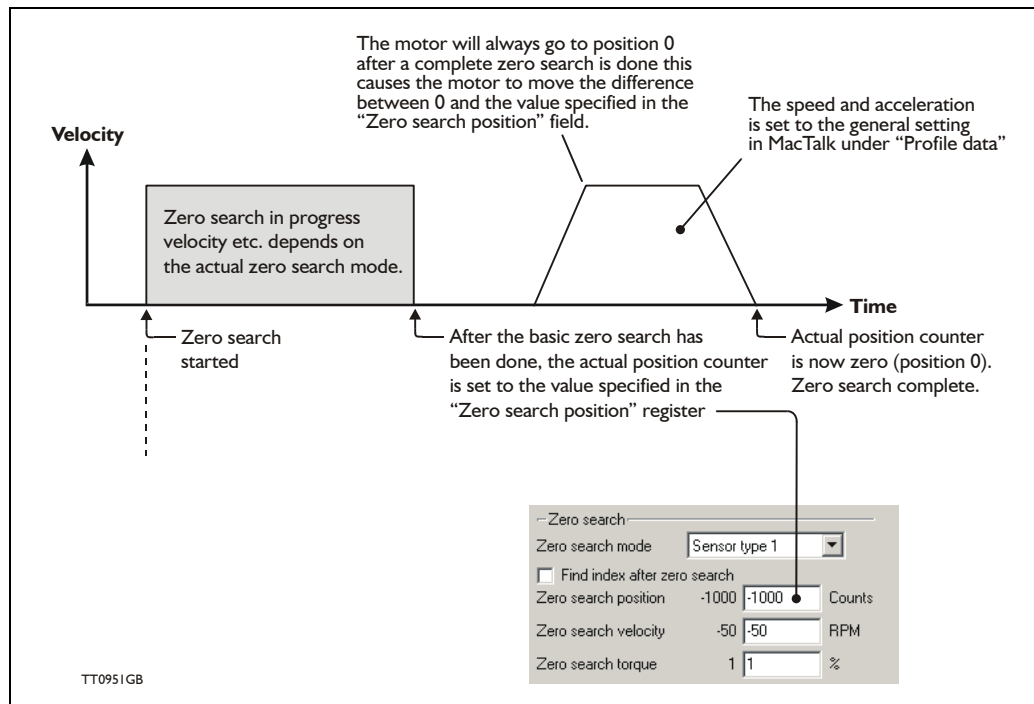

## 2.6

# Mechanical Zero search

### 2.6.12 Find index position after Zero search

The motor offers 2 unique points per revolution called the index points. These points are found by the internal hall sensors and are always the same.

By enabling the 'Find index after Zero search' feature, an extra precise zero point can be defined.

This feature is intended to be used if the external sensor does not offer the desired precision. The feature can be used after each of the basic Zero search modes including the torque Zero search mode.

Enable the index search feature in the **Main** window.

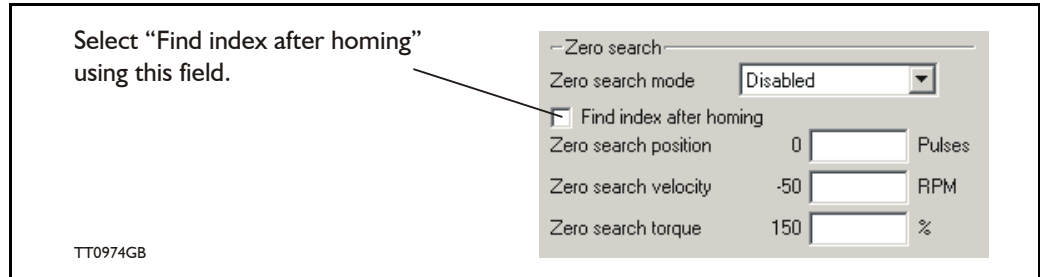

When the feature is selected, it is very important that the external Zero search sensor is adjusted to the correct position range with a certain margin to the index points to ensure the same index is always found during every Zero search. If the external sensor is activated too close to the index points, it can cause the motor to finalize the Zero search with reference to the wrong index point, which in practice will constitute an error of 0.5 motor revolution. Adjustment of the Zero search point must be done regardless of which of the 6 (3) Zero search formats is selected.

The illustration below shows the MacTalk **Tests** tab which must be used for adjusting the Zero search point.

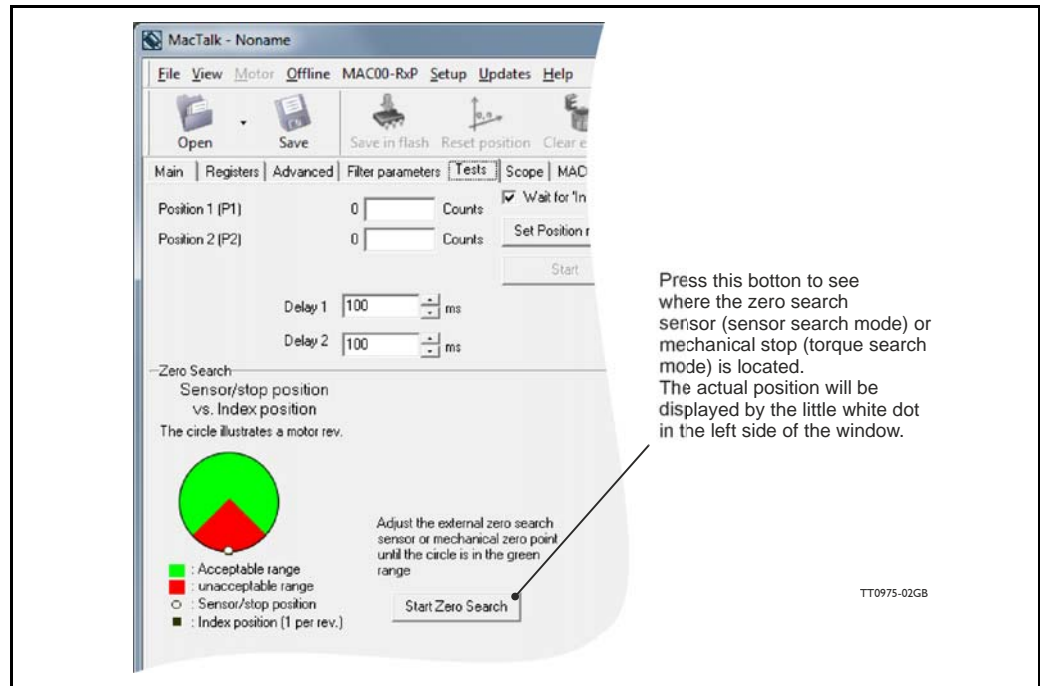

Ensure that the zero point test is made several times to ensure that the white dot is located in the acceptable interval each time.

## 2.7 Error messages and error handling

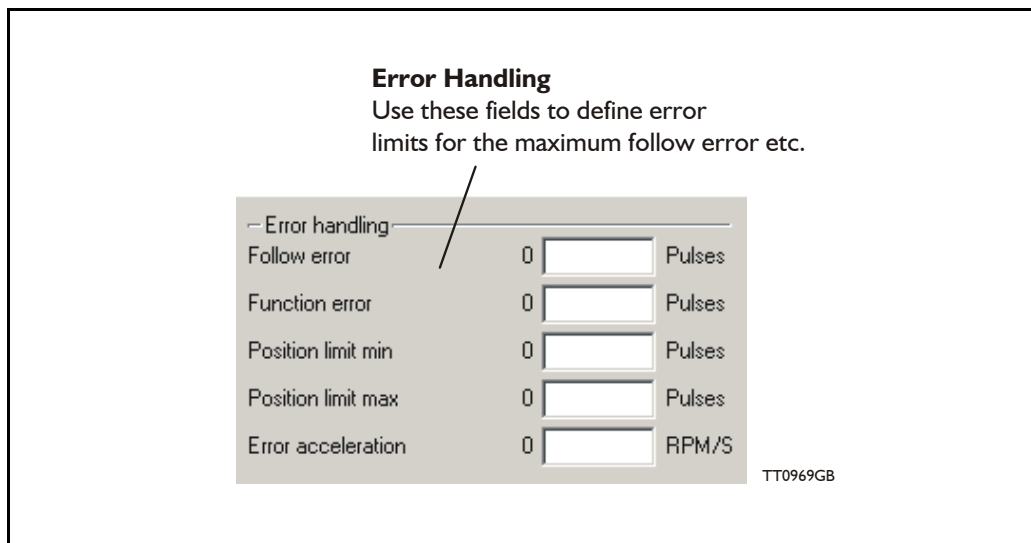

### 2.7.1 Error messages and error handling

The MAC motor incorporates 5 fundamental parameters used for protection-related purposes. They all have effect regardless of the operation mode the motor is set up to use.

#### Follow error

It is possible to define the maximum allowable difference between the actual position of the motor and the desired position. Depending on the setting of the servo filter etc., this position difference will change. For protection it can be useful to define that the difference is not allowed to exceed for example 500 counts (the motor has 4096 counts per rev. fixed). If a mechanical collision occurs, the position difference will typically be exceeded and cause a follow error making the motor passive with no further movement. The default is 0, meaning that the feature is disabled.

#### Function error

Similar to Follow Error but the number of difference counts is only measured from the point where the peak torque is reached, making it impossible for the motor to follow the commanded movement. Default is 0, meaning that the feature is disabled.

#### Position limit min. and max.

Same as the physical limit switches but performed by software. Default is 0, meaning that the feature is disabled.

#### Error acceleration

If an unrecoverable error occurs, it can be expedient to use a controlled deceleration instead of a sudden stop. If the inertia in the system is high and the mechanical parts are weak, a sudden stop can cause damage and unintended behaviour. Use this parameter to define the deceleration during an unrecoverable error. Default is 0, meaning that the feature is disabled.



## 2.7 Error messages and error handling

### 2.7.2 Monitoring errors and warnings

When using the MacTalk PC-program any error or warning is shown in 'Status' field at the main tab.

General error and warning monitoring area

In this area actual values for the motor operation is monitored continuously. Most of these monitored values will trip a corresponding error message.

Example : The error message 'Overload' will be tripped if the the monitored value 'Motor load (mean)' gets above 99%. Therefore make sure that the value during normal operation have a proper margin to 100%.

Actual error(s) are shown here if any

Warnings and status information are presented here

Motor status:

Actual mode	Passive
Actual velocity	0 RPM
Actual position	-2 Counts
Follow error	0 Counts
Function error	0 Counts
Actual motor torque	0 %
Motor load (mean)	0 %
Regenerative load	0 %
Temperature	76 °C

Inputs:

Bus voltage	6 Volts
Control voltage	24 Volts

Errors:

Temperature too high

Status:

- Motor in position
- Motor accelerating
- Motor decelerating
- Intermediate power DC voltage low
- Supervision of position limits disabled
- Mains AC voltage
- Driver stage disabled

TM170GB

### 2.7.3 Error message 'Ohmic losses too high'

The following list show the possible error messages, the cause of the error and possible actions to prevent the error from happening.

Each error can also be monitored by reading the error status register (register 35) by using software packages like the OCX driver or MacRegIO.

Message no. / Message	1 / 'Overload'
Type / Motor action	Unrecoverable error / Motor is set in passive mode.
Error condition	The calculated accumulated losses in the motor and electronics above limit. The actual level of losses can be observed in the 'Motor load (mean)' field (see the screen dump above).
Possible cause of this error	The motor has been loaded above maximum continuous torque rating for too long time, causing a critical internal temperature.
Solutions to avoid error	<ul style="list-style-type: none"> <li>- Reduce average motor load.</li> <li>- Reduce the speed and/or acceleration.</li> <li>- Adjust servo filter to a stable behaviour during any event.</li> <li>- Make sure that the supply voltage is at the specified level.</li> </ul>
How to return to normal operation	- Reset the motor, clear the error bit(s) in register 35 or cycle the power.
Error bit / Firmware name	Bit 0 / 'I2T_ERR'

## 2.7 Error messages and error handling

### 2.7.4 Error message 'Follow error'

<b>Message no. / Message</b>	<b>2 / 'Follow error'</b>
Type / Motor action	Unrecoverable error / Motor is set in passive mode.
Error condition	The actual difference between the actual motor position and the intended position is higher than the value specified in the 'Maximum follow error' field in MacTalk.
Possible cause of this error	The motor has been applied too high a load or the 'maximum follow error' value have been set at an unrealistic low value in regards to the actual hardness of the servo filter.
Solutions to avoid error	<ul style="list-style-type: none"> <li>- Increase the "Maximum follow error' value.</li> <li>- Adjust the servo filter hardness to a more aggressive value.</li> <li>- Make sure that the torque setting is not limiting the motor movement.</li> <li>- Set the 'Maximum follow error' to 0 (default) which will disable the detection of this error type.</li> </ul>
How to return to normal operation	- Reset the motor, clear the error bit(s) in register 35 or cycle the power.
Error bit / Firmware name	Bit 1 / 'FLW_ERR'

### 2.7.5 Error message 'Function error'

<b>Message no. / Message</b>	<b>3 / 'Function error'</b>
Type / Motor action	Unrecoverable error / Motor is set in passive mode.
Error condition	If the actual load torque of the motor gets higher than the specified torque setting permits it will cause the motor to slip away from where it is supposed to be. If the number of motor counts missing in this situation gets higher than the value specified in the 'Maximum function error' field in MacTalk it will trigger the 'function error'. If the actual motor torque never reaches the value specified in the 'torque' field this error will never be triggered. The above condition is valid when the motor is operated in Position mode, Biposition mode, or Analogue to position mode.
Possible cause of this error	The motor has been applied too high a load or the 'maximum function error' value have been set at an unrealistic low value in regards to the 'torque' setting.
Solutions to avoid error	<ul style="list-style-type: none"> <li>- Increase the 'Maximum follow error' value.</li> <li>- Adjust the servo filter hardness to a more aggressive value.</li> <li>- Make sure that the torque setting is not limiting the motor movement.</li> <li>- Set the 'Maximum function error' to 0 (default) which will disable the detection of this error type.</li> </ul>
How to return to normal operation	- Reset the motor, clear the error bit(s) in register 35 or cycle the power.
Error bit / Firmware name	Bit 2 / 'FNC_ERR'

## 2.7 Error messages and error handling

### 2.7.6 Error message 'Regenerative overload'

Message no. / Message	4 / 'Regenerative overload'
Type / Motor action	Unrecoverable error / Motor is set in passive mode.
Error condition	The amount of power dissipated in the motors built-in power dump (breaking) resistor is above safe limit. This error is tripped if the 'Regenerative load' is >99%. The regenerative load value can be monitored in the 'Motor status field'.
Possible cause of this error	The returned amount of energy from the motor has been too high. This can typically happen if: <ul style="list-style-type: none"> <li>- The motor decelerate a large load inertia too fast.</li> <li>- The motor is forced backwards.</li> <li>- The servo filter or 'Load' parameter is not adjusted to a stable motor operation and the motor tends to oscillate causing energy to flow forward and backward from/to the motor.</li> </ul> In all situations the motor will start to work as a generator that generate energy backward into the drive electronics.
Solutions to avoid error	<ul style="list-style-type: none"> <li>- Decrease the load inertia.</li> <li>- Decrease the top speed and/or the acceleration value.</li> <li>- Make sure that the supply voltage is within nominal range in order to leave extra capacity at the internal capacitors.</li> </ul>
How to return to normal operation	<ul style="list-style-type: none"> <li>- Reset the motor, clear the error bit(s) in register 35 or cycle the power.</li> </ul>
Error bit / Firmware name	Bit 3 / 'UIT_ERR'

Error message 5, 6 and 7 do not exist since bits are used for other status purposes.

### 2.7.7 Error message 'Position Limit Exceeded'

Message no. / Message	8 / 'Position Limit Exceeded'
Type / Motor action	Unrecoverable error / Motor is set in passive mode.
Error condition	The actual position of the motor is outside the value(s) specified in the 'position limit min.' or 'position limit max.' specified in the 'error handling' area of the main tab in MacTalk.
Possible cause of this error	The motor has been commanded outside the value(s) specified in the 'position limit min.' or 'position limit max.' registers. Be aware that the error can happen even if the motor is in passive mode and the motor is forced outside this range.
Solutions to avoid error	<ul style="list-style-type: none"> <li>- Set the position limits described above to more realistic values.</li> <li>- Make sure that the position limits also cover worst case situations such as position overshoot (if using a soft filter).</li> </ul>
How to return to normal operation	<ul style="list-style-type: none"> <li>- Reset the motor, clear the error bit(s) in register 35 or cycle the power.</li> </ul>
Error bit / Firmware name	Bit 7 / 'PLIM_ERR'

## 2.7 Error messages and error handling

### 2.7.8 Error message 'Temperature too high' (only MAC400 to MAC3000)

Message no. / Message	<b>9 / 'Temperature too high'</b>
Type / Motor action	Unrecoverable error / Motor is set in passive mode.
Error condition	The temperature has been higher than 84°C (183F) which is not allowed. Please note that this error is only available in MAC400, MAC402, MAC800, MAC1500 and MAC3000 since MAC050-141 do not include a temperature measurement circuit.
Possible cause of this error	<ul style="list-style-type: none"><li>- The ambient temperature is higher than allowed - max is +40°C/104°F.</li><li>- The motor is build into an environment where it can not dissipate enough heat.</li><li>- The motor is not mounted on a proper mechanical structure where heat can be dissipated.</li></ul>
Solutions to avoid error	<ul style="list-style-type: none"><li>- Make precautions to decrease the surrounding ambient temperature.</li><li>- Lower the speed and or load on the motor.</li></ul>
How to return to normal operation	<ul style="list-style-type: none"><li>- Reset the motor, clear the error bit(s) in register 35 or cycle the power.</li></ul>
Error bit / Firmware name	Bit 8 / 'DEGC_ERR'

### 2.7.9 Error message 'Low AC-voltage' (only MAC400 to MAC3000)

Message no. / Message	<b>10 / 'Low AC-voltage'</b>
Type / Motor action	Unrecoverable error / Motor is set in passive mode.
Error condition	The mains supply is not connected or the mains voltage is too low. Please note that this message is only available in MAC400, 402, 800, 1500 and 3000 since MAC050-141 do not include AC supply.
Possible cause of this error	<ul style="list-style-type: none"><li>- The mains supply is not connected correctly.</li><li>- The external fuse has blown.</li></ul>
Solutions to avoid error	<ul style="list-style-type: none"><li>- Make sure that the external fuse is OK and that the mains supply is connected correctly according to the chapter <i>Power Supply, page 87</i>.</li></ul>
How to return to normal operation	<ul style="list-style-type: none"><li>- Reset the motor, clear the error bit(s) in register 35 or cycle the power. See also the chapter <i>Under Voltage Handling, page 52</i>.</li></ul>
Error bit / Firmware name	Bit 9 / 'UV_ERR'

Error message 11 do not exist since bits are used for other status purposes.

## 2.7 Error messages and error handling

### 2.7.10 Error message 'Phase error' (only MAC050 to 141)

Message no. / Message	<b>12 / 'Phase error'</b>
Type / Motor action	Unrecoverable error / Motor is set in passive mode.
Error condition	The motor phase current has been measured to be Out of Range and the motor driver is shut down to prevent permanent failure. Please note that this message is only available in MAC050 to MAC141.
Possible cause of this error	<ul style="list-style-type: none"> <li>- The servofilter (control loop) is unstable.</li> <li>- The motor has been physically blocked.</li> <li>- The motor has been running into a sudden mechanical collision.</li> </ul>
Solutions to avoid error	<ul style="list-style-type: none"> <li>- Make sure that the servo filter is not set to an extreme unrealistic setting compared to the nature of the actual load. See also <i>Servo filter adjustment, page 53</i>.</li> <li>- Avoid that the motor during normal operation is meeting a mechanical collision or an extreme overload situation.</li> </ul>
How to return to normal operation	- Reset the motor, clear the error bit(s) in register 35 or cycle the power.
Error bit / Firmware name	Bit 11 / 'IX_ERR'

### 2.7.11 Error message 'Overvoltage on bus' (only MAC400 to MAC3000)

Message no. / Message	<b>12 / 'Overvoltage on bus'</b>
Type / Motor action	Unrecoverable error / Motor is set in passive mode.
Error condition	The internal busvoltage has been higher than 450VDC which is not allowed in order to prevent damages of the motor. Please note that this message is only available in MAC400, MAC402, MAC800, MAC1500 and MAC1500.
Possible cause of this error	<ul style="list-style-type: none"> <li>- The internal brake resistor is not sufficient to handle the amount of returned energy from the motor. Use an external resistor or if already present lower the value of the resistor.</li> <li>- The mains supply voltage is too high.</li> </ul>
Solutions to avoid error	<ul style="list-style-type: none"> <li>- Make sure that the mains voltage is within specified voltage range.</li> <li>- If this error only happens during a motor movement the error can probably be avoided by connecting an external power dump resistor or decrease the ohmic value if a resistor is already present. See also <i>Connecting an external power dump resistor, page 102</i>.</li> </ul>
How to return to normal operation	- Reset the motor, clear the error bit(s) in register 35 or cycle the power.
Error bit / Firmware name	Bit 11 / 'OV_ERR'

## 2.7 Error messages and error handling

### 2.7.12 Error message 'UnderVoltage on Bus' (only MAC050 to 141)

Message no. / Message	<b>13 / 'UnderVoltage on Bus'</b>
Type / Motor action	Unrecoverable error / Motor is set in passive mode.
Error condition	The voltage of the DC powersupply has been measured to be lower than the limit selected in the register 'Min voltage'. This has resulted in an error as configured in the setup of 'Undervoltage handling'. See also <i>Under Voltage Handling, page 52</i> . Please note that this message is only available in MAC050 to MAC141.
Possible cause of this error	<ul style="list-style-type: none"> <li>- The current rating of the external power supply is too small.</li> <li>- The power supply is not able to deliver the required peak currents that the motor need. This is a typical problem when using switch mode power supply.</li> <li>- The power cable is under dimensioned.</li> <li>- The under voltage min. setting must be decreased.</li> </ul>
Solutions to avoid error	<ul style="list-style-type: none"> <li>- Use a power supply with a higher current rating.</li> <li>- Use a power cable with at least 0,75mm<sup>2</sup> wires (up to cable lengths of 10m. If the power cable is longer, use 1,5mm<sup>2</sup> or use multiple wires in parallel.</li> <li>- Connect a capacitor across the supply line close to the motor. Especially if using a switch mode power supply this will help. See also <i>Power supply (only MAC050 to 141), page 87</i>.</li> </ul>
How to return to normal operation	- Reset the motor, clear the error bit(s) in register 35 or cycle the power.
Error bit / Firmware name	Bit 12 / 'UV_ERR'

### 2.7.13 Error mess. 'Peak error, motor overcurrent' (only MAC400 to 3000)

Message no. / Message	<b>13 / 'Peak error, motor overcurrent'</b>
Type / Motor action	Unrecoverable error / Motor is set in passive mode.
Error condition	The motor phase current has been measured to be Out of Range and the motor driver is shut down to prevent permanent failure. Please note that this message is only available in MAC400, 402, 800, 1500 and MAC3000.
Possible cause of this error	<ul style="list-style-type: none"> <li>- The servofilter (control loop) is unstable.</li> <li>- The motor has been physically blocked.</li> <li>- The motor has been running into a sudden mechanical collision.</li> <li>- The actual AC supply voltage is too low to run the motor at the actual speed.</li> </ul>
Solutions to avoid error	<ul style="list-style-type: none"> <li>- Make sure that the servo filter is not set at an extreme unrealistic setting compared to the nature of the actual load. See also <i>Servo filter adjustment, page 53</i>.</li> <li>- Avoid that the motor during normal operation is meeting a mechanical collision or an extreme overload situation.</li> </ul>
How to return to normal operation	- This error type is not software resetable. Cycle the control voltage (24VDC).
Error bit / Firmware name	Bit 12 / 'IPEAK_ERR'

## 2.7 Error messages and error handling

### 2.7.14 Error message 'Overspeed' (only MAC400 to MAC3000)

Message no. / Message	<b>14 / 'Overspeed'</b>
Type / Motor action	Unrecoverable error / Motor is set in passive mode.
Error condition	The actual velocity (speed) has been higher than allowed. Please note that this message is only available in MAC400, 402, 800, 1500 and MAC3000.
Possible cause of this error	<ul style="list-style-type: none"><li>- Velocity too high.</li><li>- Servofilter is not stiff enough and speed may overshoot during start and/or stop or when sudden load changes happens. This error is triggered at 4300 RPM (MAC400 and MAC402) and 3600 RPM (MAC800, MAC1500 and MAC3000).</li></ul>
Solutions to avoid error	<ul style="list-style-type: none"><li>- Make sure that the velocity setting is within specified range (0-3000 RPM nominal).</li><li>- Make sure that the servo filter is set to stable setting in order to avoid overshoots during acceleration or similar. See also <i>Servo filter adjustment, page 53</i>.</li></ul>
How to return to normal operation	<ul style="list-style-type: none"><li>- Reset the motor, clear the error bit(s) in register 35 or cycle the power.</li></ul>
Error bit / Firmware name	Bit 13 / 'SPEED_ERR'

Error message 15 do not exist since bits are used for other status purposes.

### 2.7.15 Error message 'SSI Read error' (only MAC050 to 141)

Message no. / Message	<b>16 / 'SSI Read error'</b>
Type / Motor action	Unrecoverable error / Motor is set in passive mode.
Error condition	An external SSI encoder has been enabled but communication with the encoder has failed.
Possible cause of this error	<ul style="list-style-type: none"><li>- The encoder is not connected correctly.</li><li>- The format chosen is not compatible with the actual encoder.</li><li>- Improper cabling have been used.</li></ul>
Solutions to avoid error	<ul style="list-style-type: none"><li>- Use proper cabling between the motor and the external SSI encoder. A screened cable with twisted pair wires is recommended.</li><li>- Make sure that the right SSI format is selected.</li></ul>
How to return to normal operation	<ul style="list-style-type: none"><li>- Reset the motor, clear the error bit(s) in register 35 or cycle the power.</li></ul>
Error bit / Firmware name	Bit 15 / 'SSI_ERR'

## 2.7 Error messages and error handling

### 2.7.16 Error message 'Internal Encoder error' (only MAC400 to MAC3000)

Message no. / Message	<b>16 / 'Internal Encoder error'</b>
Type / Motor action	Unrecoverable error / Motor is set in passive mode.
Error condition	A malfunction in the internal encoder has been detected.
Possible cause of this error	<ul style="list-style-type: none"><li>- The encoder disc is broken because the motor have been exposed to mechanical shock. Typical the shaft have been hit very hard during mounting of the motor.</li></ul>
Solutions to avoid error	<ul style="list-style-type: none"><li>- Do not expose the shaft or the motor for mechanical shocks.</li></ul>
How to return to normal operation	Return the motor for service.
Error bit / Firmware name	Bit 15 / 'INDEX_ERR'

### 2.7.17 Error message 'Invalid Filter settings' (only MAC400 to MAC3000)

Message no. / Message	<b>17 / 'Invalid Filter settings'</b>
Type / Motor action	Unrecoverable error / Motor is set in passive mode.
Error condition	The servo filter settings are not within valid ranges.
Possible cause of this error	<ul style="list-style-type: none"><li>- The setup file used has been corrupted.</li><li>- The setup file used is an old type not compatible with the actual motor version.</li></ul>
Solutions to avoid error	<ul style="list-style-type: none"><li>- Select a new filter or contact your JVL.</li></ul>
How to return to normal operation	<ul style="list-style-type: none"><li>- Correct the servo filter setting. See also <i>Servo filter adjustment</i>, page 53.</li><li>- Cycle the 24VDC power.</li></ul>
Error bit / Firmware name	Bit 16 / 'OLD_FILTER'

### 2.7.18 Error mess. 'Control voltage unstable' (only MAC400 to MAC3000)

Message no. / Message	<b>18 / 'Control voltage unstable'</b>
Type / Motor action	Unrecoverable error / Motor is set in passive mode.
Error condition	The control voltage (24VDC at the P+ and P- terminals) has been unstable and detected outside the specified voltage range for a too long time.
Possible cause of this error	<ul style="list-style-type: none"><li>- The control voltage has been detected outside the nominal voltage range.</li><li>- The voltage has been applied too slowly with variations.</li></ul>
Solutions to avoid error	<ul style="list-style-type: none"><li>- Make sure that the voltage is stable in the specified voltage interval.</li><li>- Make sure that the voltage is applied in less than 500mS.</li></ul>
How to return to normal operation	<ul style="list-style-type: none"><li>- Cycle the 24VDC power. A reset will not clear the error.</li></ul>
Error bit / Firmware name	Bit 17 / 'U24V'



## 2.7 Error messages and error handling

### 2.7.19 Error message 'PWM locked' (only MAC400 to MAC3000)

Message no. / Message	<b>21 / 'PWM Locked'</b>
Type / Motor action	Unrecoverable error / Motor is set in passive mode.
Error condition	An unrecoverable error has occurred and the motor output driver is shut down in order to prevent any further damages. This error always takes place in combination with one or more other errors. These errors can be one of following: <ul style="list-style-type: none"> <li>- "Peak error, motor over current" (Bit 12) The motor current has been significantly higher than allowed during normal operation.</li> <li>- "Internal Encoder Error" (Bit 15). The internal encoder has a fault.</li> <li>- "Invalid Filter settings" (Bit 16). The actual filter used is an old version or corrupted because wrong values have been transferred to the motor.</li> <li>- "Control voltage unstable" (Bit 17). The 24V control voltage has been unstable.</li> </ul>
Possible cause of this error	This error is always followed by other error messages. See individual description of these errors. See also error condition above.
Solutions to avoid error	- See other error messages that follows this error.
How to return to normal operation	- This error type is not software resettable. Cycle the control voltage (24VDC).
Error bit / Firmware name	Bit 20 / 'PWM_LOCKED'

### 2.7.20 Error message 'Modbus Com. Error' (only MAC400 to MAC3000)

Message no. / Message	<b>22 / 'Modbus Com. Error'</b>
Type / Motor action	Unrecoverable error / Motor is set in passive mode.
Error condition	Modbus communication has not been possible due to a communication error.
Possible cause of this error	- The motor is setup as master but it has not been possible to reach a slave motor. - The motor is setup as a slave but do not receive any position information
Solutions to avoid error	- If the actual system is a master/slave configuration, make sure that a slave motor is present. - Make sure that the cabling is made in a proper manner with twisted pair wires and screened cable. - Make sure that the opposite unit in the communication system uses same parameters such as baudrate etc. - Adjust the time out register.
How to return to normal operation	- The error is cleared if error free communication is re-established but the motor need to be re-entered in the desired operation mode. - Try to save actual settings and restart the motor by a reset or cycle the power (24VDC).
Error bit / Firmware name	Bit 21 / 'COM_ERR'

## 2.7 Error messages and error handling

### 2.7.21 Error message 'Current loop error' (only MAC400 to MAC3000)

Message no. / Message	<b>23 / 'Current loop error'</b>
Type / Motor action	Unrecoverable error / Motor is set in passive mode.
Error condition	Error only relevant when using the MAC00-P5 module. The 4-20mA input at the MAC00-P5 module has been detected lower than 2,0mA which is outside normal range.
Possible cause of this error	<ul style="list-style-type: none"><li>- Cable fault.</li><li>- Fault in the external 4-20mA source that feed the MAC00-P5 current input.</li></ul>
Solutions to avoid error	<ul style="list-style-type: none"><li>- Check the cable feeding the 4-20mA input.</li><li>- Make sure that the 4-20mA signal stay at a level higher than 2,0mA.</li></ul>
How to return to normal operation	<ul style="list-style-type: none"><li>- Reset the motor, clear the error bit(s) in register 35 or cycle the 24VDC power.</li></ul>
Error bit / Firmware name	Bit 22 / 'CURLOOP_ERR'

### 2.7.22 Error message 'Slave error' (only MAC400 to MAC3000)

Message no. / Message	<b>24 / 'Slave Error'</b>
Type / Motor action	Unrecoverable error / Motor is set in passive mode.
Error condition	<ul style="list-style-type: none"><li>- Modbus communication with a slave motor has not been possible due to a communication error.</li><li>- A connected slave motor has discovered an error. See the slave error register.</li></ul>
Possible cause of this error	<ul style="list-style-type: none"><li>- The motor is setup as master but it has not been possible to reach a slave motor.</li><li>- A connected slave motor has discovered an error. See the slave error register.</li></ul>
Solutions to avoid error	<ul style="list-style-type: none"><li>- If the actual system is a master/slave configuration make sure that a slave motor is present.</li><li>- Make sure that the cabling is made in a proper manner with twisted pair wires and screened cable.</li><li>- Make sure that the opposite unit in the communication system uses same parameters such as baudrate etc.</li></ul>
How to return to normal operation	<ul style="list-style-type: none"><li>- Reset the motor, clear the error bit(s) in register 35 or cycle the 24VDC power.</li></ul>
Error bit / Firmware name	Bit 23 / 'SLAVE_ERR'

## 2.8 How to monitor the motor torque and load

### 2.8.1 Monitoring motor torque and load

All the MAC motors contain a register that continuously is updated with the actual motor load integrated over some time.

The register is called I2T (melt integral) - the name in MacTalk is "Motor load (mean)". The motor can produce up to 300% torque as long as the I2T register do not reach 100%. If it reaches 100% the motor will go in passive mode and an overload error is reported. The I2T register can also be usefull to monitor the load over time to see if mechanics starts to have an unintended higher friction compared to the installation date.

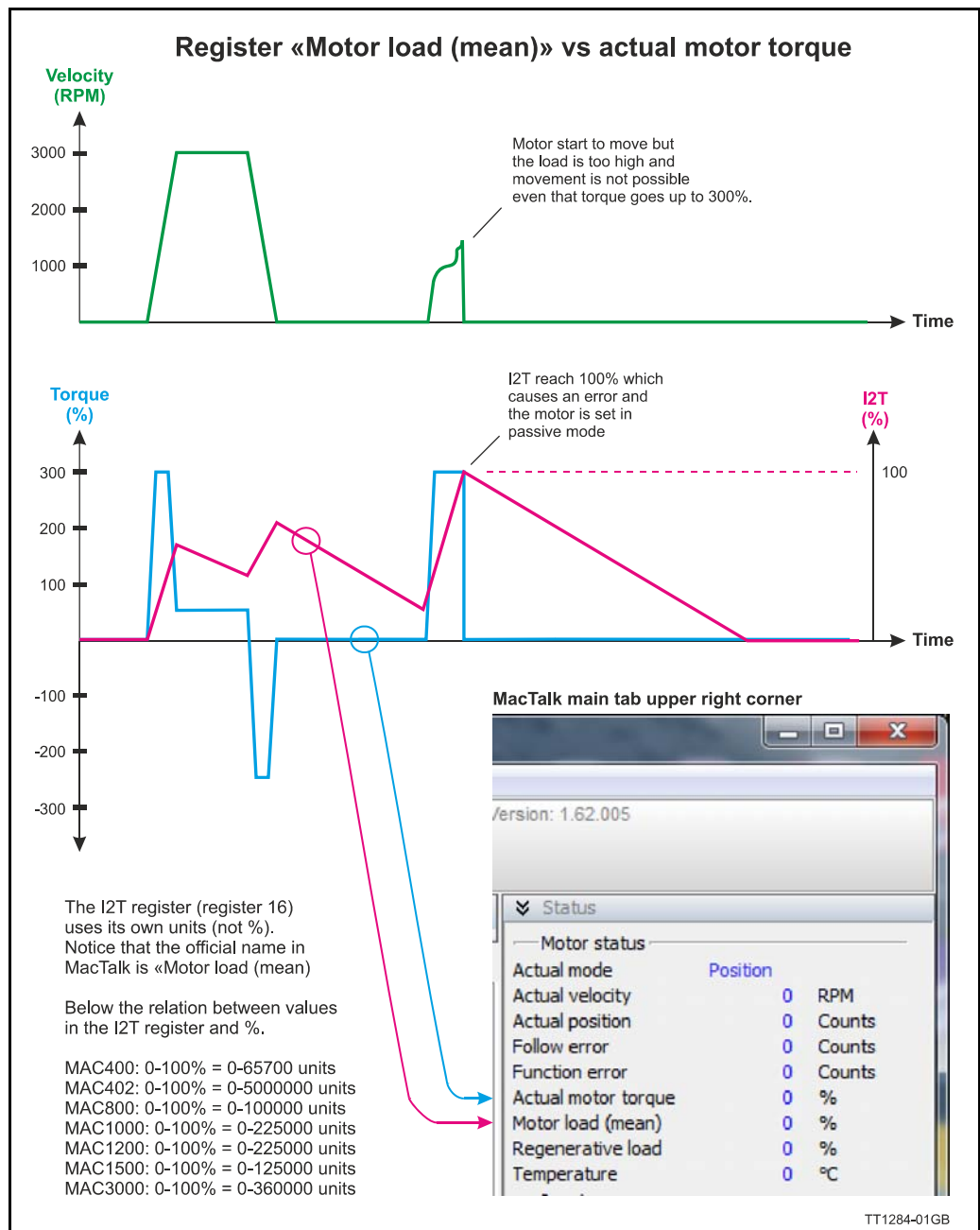

## 2.9

# Under Voltage Handling

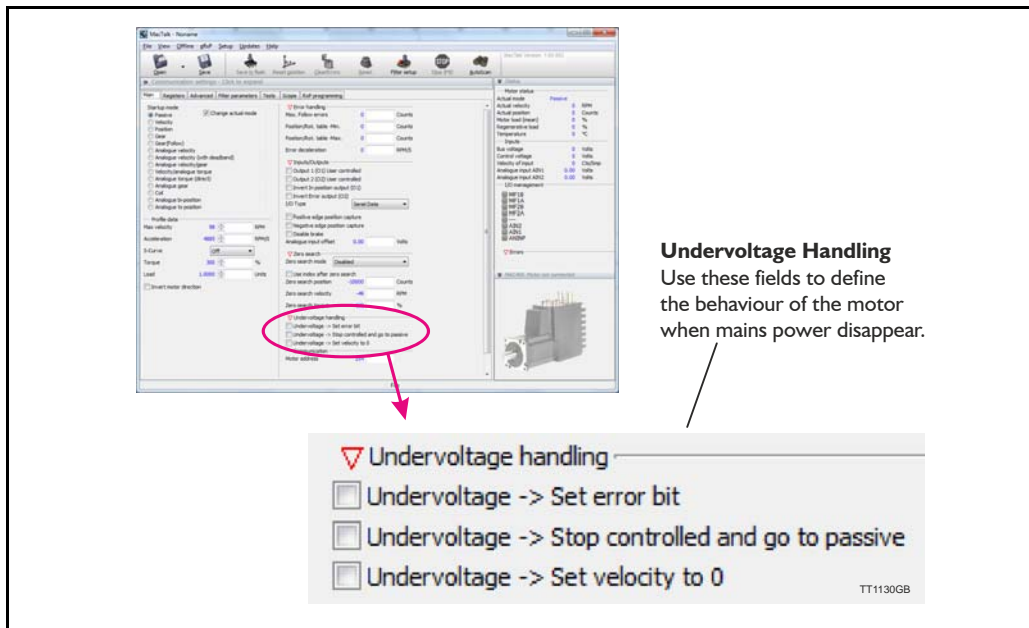

### 2.9.1 Undervoltage handling

The MAC motor offers the possibility to define the behaviour during and after the mains-voltage disappears. This situation could for example be during an emergency stop which causes the mains supply to be cut while the control voltage is still applied to the motor. 3 options exist:

### 2.9.2 Undervoltage -> Set error bit

Default = Off.

If this option is selected an under voltage will be handled like an error situation and the corresponding error bit will be set. The motor is stopped using the “error deceleration” before the motor is switched to passive mode, like any other error situation.

When the main power is re-applied the motor will stay in passive mode and report and under voltage error. To get the motor back in normal operation the error must be cleared and a operation mode must be selected.

If this function is activated it will have first priority and the error deceleration will be used compared to the 2 other options “Undervoltage -> Stop controlled and go to passive” and “Undervoltage -> Set velocity to 0” which both uses normal deceleration.

### 2.9.3 Undervoltage -> Stop controlled and go to passive

Default = Off

This option makes the motor decelerating according to the normal acceleration parameter and go to passive mode when the mains power is removed. When main power is re-applied the motor stay in passive mode. To get the motor back in normal operation an operation mode must be selected.

### 2.9.4 Undervoltage -> Set velocity to 0

Default = Off.

This option simply just set the velocity to 0 causing the motor to decelerate and stay stationary (except in “torque direct mode”) when mains power is removed. The velocity setting will stay at 0 also after the main power is re-applied. A velocity value (>0RPM) must be written into the velocity register to get the motor moving again.

## 2.10

# Servo filter adjustment

### 2.10.1 Servo filter adjustment

The MAC motor contains a higher-order digital filter regulation core. The purpose of the filter is to ensure that the desired speed, torque and/or position are achieved and secondly that stability is obtained.

The motor's default setting (when delivered) is normally appropriate for most applications. The only necessary adjustment is the *LOAD* parameter which is available via the *Main* setup in the MacTalk software. For more demanding applications, the *Filter selector* can be used.

### 2.10.2 Adjusting the LOAD parameter

The *LOAD* parameter must be increased proportional to the inertia of the payload in the system. The default value of the *LOAD* parameter is 1.0000.

The proper *LOAD* value must be determined as follows.

$LOAD = (\text{Motor inertia} + \text{Load inertia}) / \text{Motor inertia}$ .

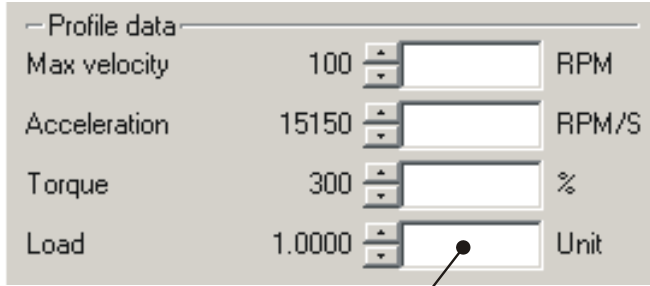

Adjust Load according to the attached inertia.

**Example:**  
A system uses a MAC800. The MAC800 has a motor inertia of 0.92kg/cm<sup>2</sup> (according to technical data in appendix). If the load inertia is 9.2kg/cm<sup>2</sup> (motor inertia x 10) the Load needs to be adjusted to

$$LOAD = (\text{Motor inertia} + \text{Load inertia}) / \text{Motor inertia}$$
$$LOAD = (0.92 + 9.2) / 0.92 = 11$$

TT1022GB

If the load inertia is not fully known, it is highly recommended to slowly increase the *LOAD* parameter until the motor starts to be unstable and noisy. Then decrease the value 20-30% to obtain a certain safety margin.

Remember to save the adjustment permanently in the motor by pressing the "Save in flash" button.

### 2.10.3 Exceptions when adjusting LOAD

Precautions must be taken if the transmission from the motor to the load is elastic or involves a certain amount of backlash. A typical situation where precautions must be taken is when using a belt drive actuator, since the motor's forces may have to be transmitted past a gear, for example, and then the belt until the payload is finally met. This "transmission chain" is typically very elastic and the gear will contain a certain amount of backlash. The main problem is that the motor does not directly "see" the final payload.

When the motor starts to rotate, it will not "sense" the payload before the backlash distance is passed and the belt is tightened. It is therefore not a linear system and the *LOAD* cannot be increased as much as in theory.

## 2.10 Servo filter adjustment

### 2.10.4 Filter selector basics

If the desired motor response cannot be achieved using only the LOAD parameter, the filter selector can be used.

The filter selector can be found in the MacTalk upper toolbar.



Using the Filter selector, the “personality” of the motor response can be optimised to specific applications. The following overall behaviours can be adjusted:

- Follow error during movement and/or when the motor is stationary.
- Stability with a high load inertia.
- Stability if the load inertia changes during operation.
- Motor noise

The filter selector is in principle the same for the complete MAC motor range except that the MAC50 to MAC141 also include the possibility to adjust the current filter.

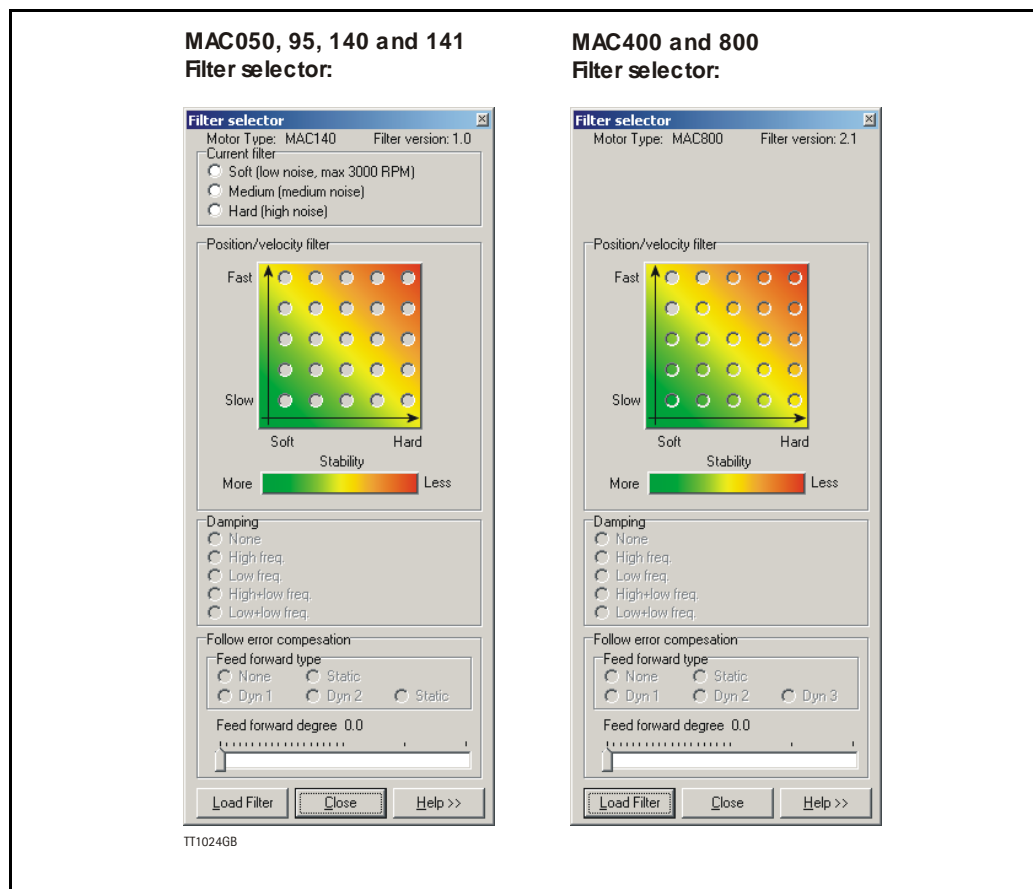

## 2.10 Servo filter adjustment

### 2.10.5 Adjusting the current filter (only MAC050 to 141)

The current filter is adjustable in the MAC050 to MAC141 models. This feature is useful if the audible noise from the motor needs to be decreased. Please note that the bandwidth of the current filter will also be lowered which can cause efficiency at higher speeds also to be lowered. As shown in the selector box below, it is not recommended to select the “Low noise” filter if the motor is operated above 3000 RPM (MAC141: 2000 RPM). A general recommendation is to select the high noise filter since it has the best dynamic performance.

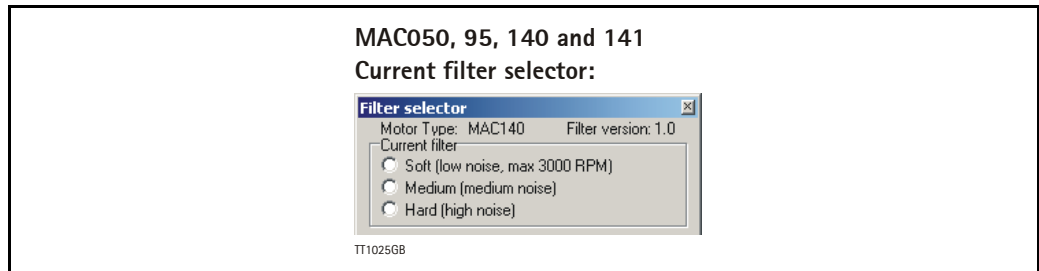

### 2.10.6 Adjusting the Position/Velocity filter

The Position/Velocity filter is the main filter which sets up the main response performance of the motor.

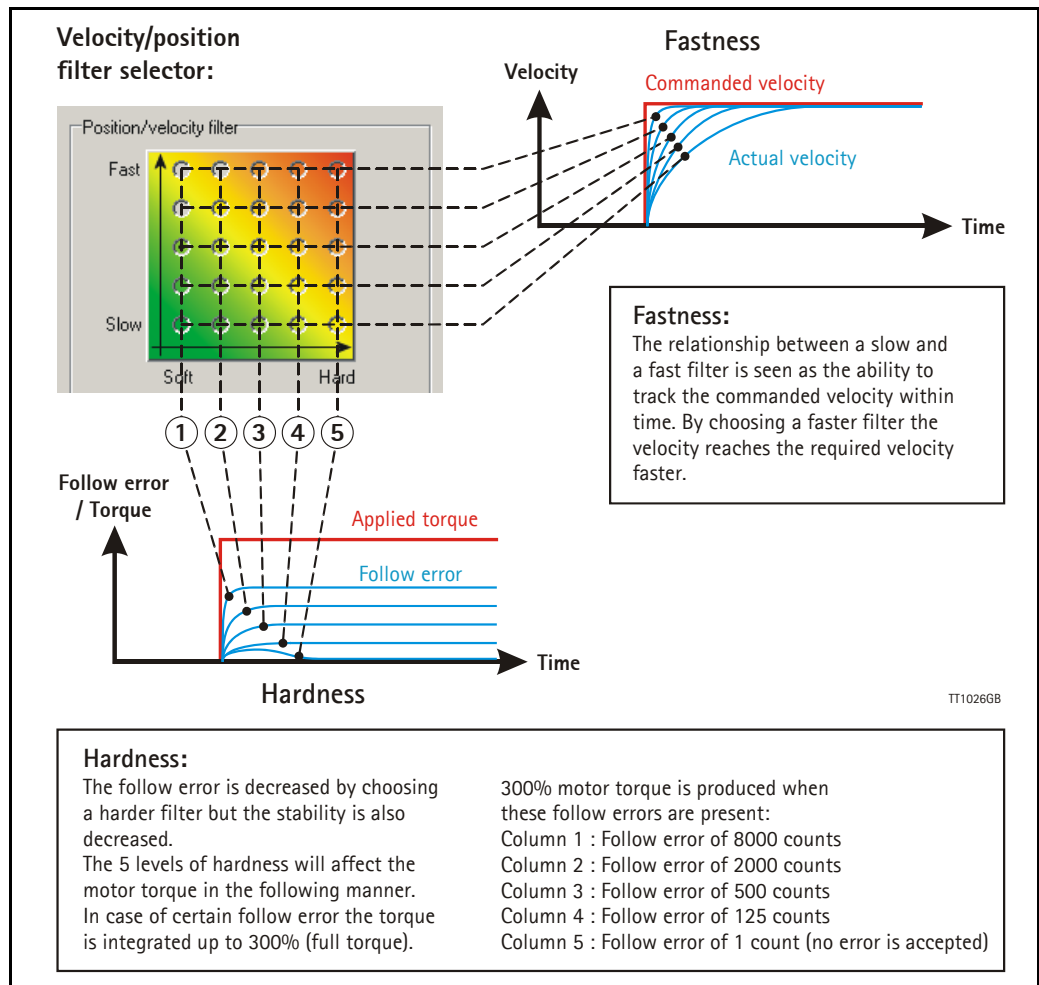

## 2.10 Servo filter adjustment

---

### 2.10.7 Damping

In almost any application it can be useful to damp (suppress) certain oscillations.

The damping selector can be used for this purpose.

The following damping types are available:

- **None**  
Damping feature is disabled.
- **Low frequency**  
When selecting *Low frequency*, oscillations caused by a poor mechanical transmission can be reduced. Poor mechanical transmission means backlash in the coupling or elastic toothbelts, etc. The filter becomes more tolerant to variations in the inertia which normally can cause the motor to become unstable.
- **High frequency**  
When selecting *High frequency*, oscillations at higher frequencies will be reduced. This can typically occur if the filter starts to oscillate at a frequency related to the sample frequency. Often this can be heard as an audible noise.
- **High+Low frequency** (only available on MAC400-800)  
This is a combination of High and Low frequency settings.
- **Low+Low frequency** (only available on MAC400-800)  
This setting is similar to Low frequency but adds extra tolerance to variations in the inertia.

#### Damping selector:

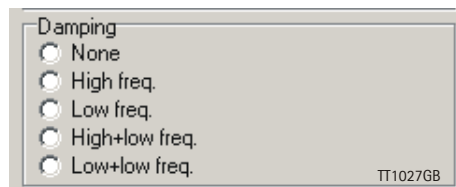



## 2.10

# Servo filter adjustment

### 2.10.8 Follow error compensation

This feature makes it possible to achieve a minimum position error during movement (dynamically). The 2 main types are:

- **Static**

Will reduce follow error at constant speed, which can be useful for electronic gear applications since the motor will follow exactly what is demanded without any position error.

- **Dynamic**

Will reduce follow error during acceleration or deceleration (speed changes). This feature is intended to be used for applications which require that a commanded speed or target position is reached as fast as possible but without any overshoots etc.

The Dynamic compensation provides 3 levels (Dyn 1 to 3). Using a higher Dyn number, the filter order is increased and better performance may be possible, but will depend on the actual application.

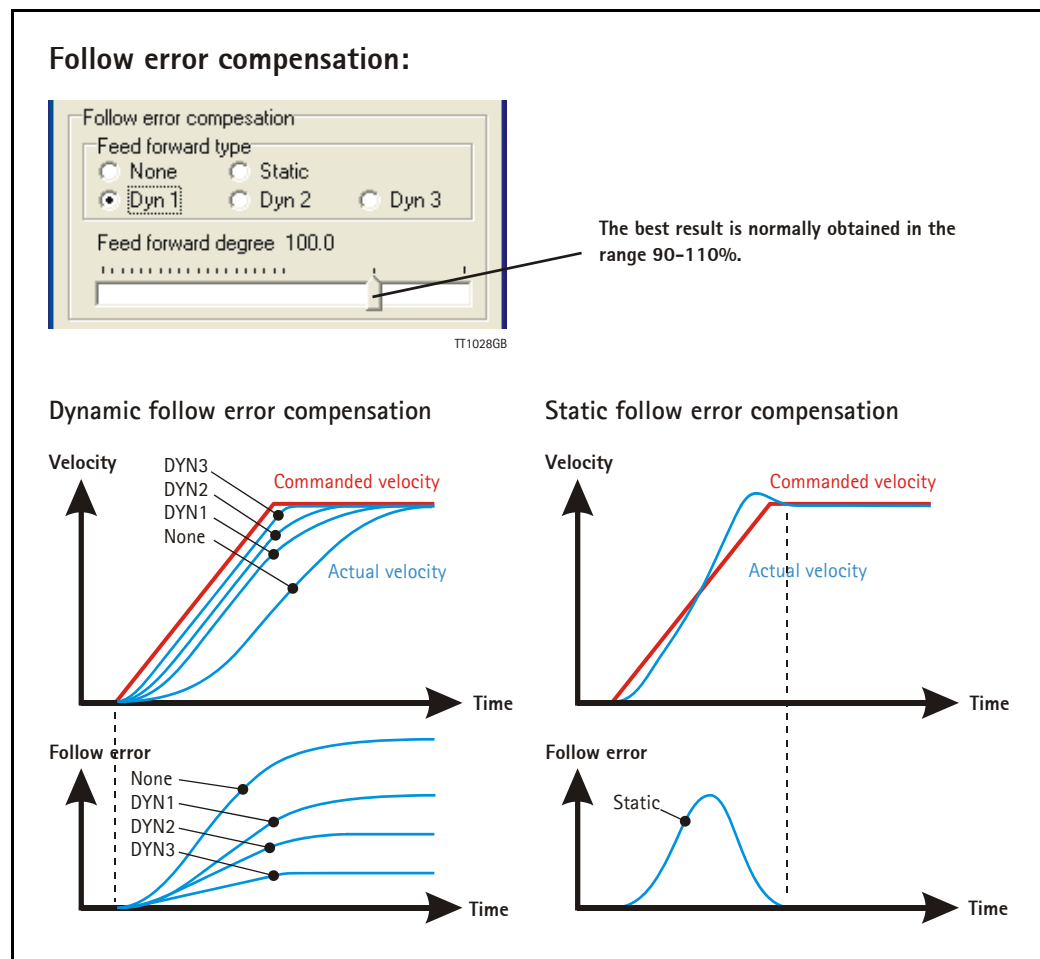

Please note that the dynamic compensation level Dyn 3 is only available on the MAC400-800 but for all motor sizes the available dynamic compensation is limited to Dyn 1 or 2 if a slow main filter is selected.

## 2.10 Servo filter adjustment

### 2.10.9 Transferring and saving the filter

After setting the filter choices, the filter can be transferred to the motor.

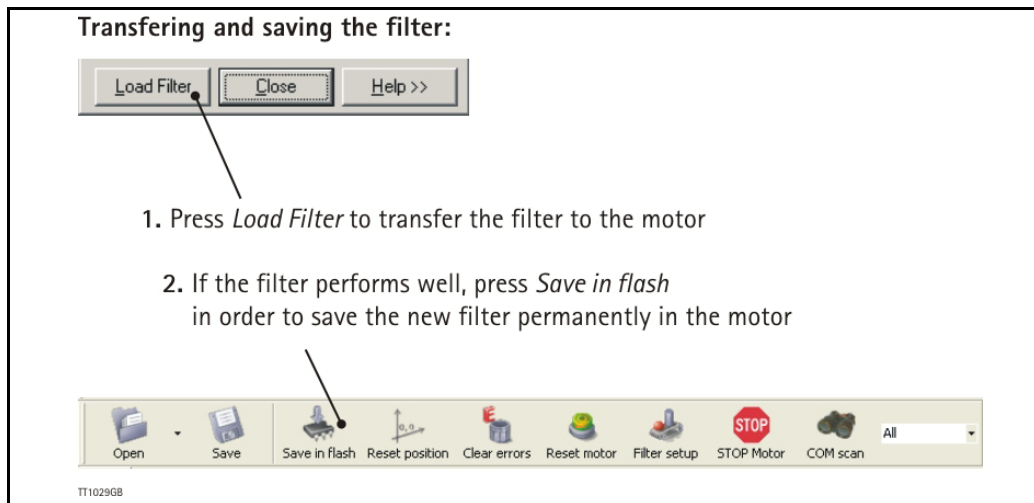

The complete setup including the filter configuration can also be saved to and later recalled from disc by using the *Open* and *Save* buttons in the toolbar.

### 2.10.10 Additional adjustment

Now the desired filter is set up in the motor and the performance can be tested. Further improvement may be required and typically it may be necessary to experiment in order to obtain an optimum result.

Please note that the **LOAD** parameter must still be used to adjust the inertia ratio between the motor and load. See also *Adjusting the LOAD parameter*, page 53.

## 2.11 Using external SSI encoder

Only MAC050 to I41

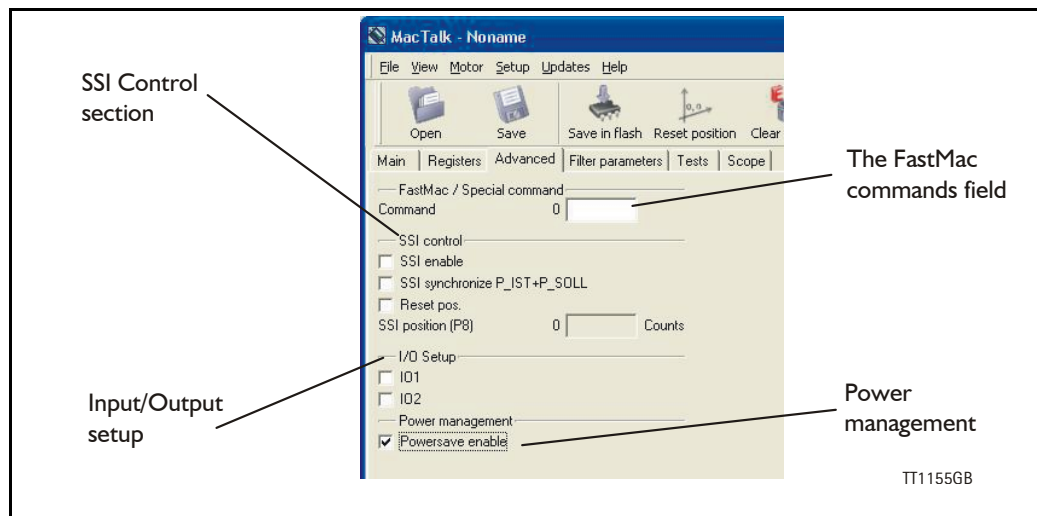

### 2.11.1 SSI Encoder

SSI support is added to the MAC50-I41 series of servomotors, this feature is very useful to determine the absolute position of the motor shaft if an encoder is connected directly to this or another encoder position.

#### The SSI interface

When the differential lines are used for SSI, the AI +/- lines work as a Clock signal from the motor to the encoder, while the BI +/- signals work as a Data signal from the encoder to the motor.

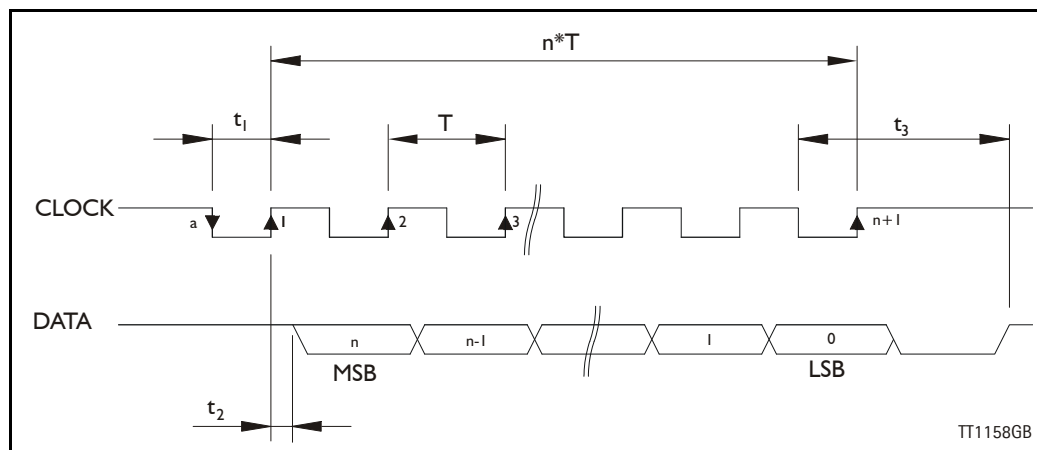

The figure above shows the SSI protocol principle. The Clock line is normally high. When a reading is requested, the Clock goes low for  $t_1$  micro seconds to allow the encoder to sample and prepare a value. On the first rising edge of the Clock (1), no sampling is done, but on the second rising edge of the Clock (2) the first data bit is read from the Data line. Shortly after reading the bit value, the motor will set the Clock high and execute another cycle, where the data bit is sampled just before each rising Clock. After the last data bit has been sampled, the Clock stays high.

In the MAC-motor several registers are available for storing values for different purposes. Position registers P1-P8 (available from MacTalk etc.) are used to hold SSI positions.

## 2.11

## Using external SSI encoder

Only MAC050 to I4I

When the motor starts up during power on or a software reset the SSI encoder is read 4x and the value is decoded from Gray-code to an absolute position with an 25bit accuracy (25-bit signed).

This position is scaled to fit motor resolution and then saved in position register P7 (register 61) as a 32-bit signed value.

The SSI encoder feature is based on an external encoder resolution of 1024 cnt/rev. (256 pulses/rev.) this value is scaled to fit the motor resolution which is 4096 cnt/rev.

SSI is a serial protocol without any error detection or correcting features so in order to determine if the correct value is read, the value is read 4 times and the same value need to be read all 4 times.

If this value has changed during the read cycle, the error register 35 bit 15 is set and also bit 15 in the SSI control register 178.

If this error condition has happened be sure to clear the error in register 178 before doing a save in flash operation.

### 2.11.2 Encoder positioning and usage

A new position is calculated based on the encoder position stored in P7 and a previously saved value (a position sample) in register P6.

This value stores in P6 is a position reference stored when a position reset is done.

The calculation is as follows:

$$P8 = (P7 - P6) + P5$$

The P5 value is used when an offset is to be added to the position. So the desired '0' position is saved into P6 and the actual position (from the encoder) is saved into P7 and then again P5 is used to offset this position.

*Example 1:*

The encoder shaft is connected to the motor shaft, meaning that 1 revolution at the external encoder is equal 4096 motor counts.

Motor start up, encoder reading = 12288 (random position)

Motor P\_IST = P\_SOLL = 12288

This position we want to define as position 0 so we run the position reset procedure (see Reset position procedure) and store 12288 into P6.

The motor is reset (software reset or power cycle) and the new position is calculated by:

P4 is by default 0, so

$P8 = (12288 - 12288)$

$P8 = 0$

This value is transferred to P\_IST and P\_SOLL, so

$P\_IST = P\_SOLL = P8 = 0.$

Now the encoder position 12288 is defined as position 0 in the system.

*Example 2:*

Let's say that we need to define a fixed position as position = 100 because we want our motor to be 100 counts from the actual 0-position at exactly this physical position.

## 2.11 Using external SSI encoder

Only MAC050 to 141

We set  $P5 = 100$  and save this position into flash (set register 211 = 2).  
 In the previous example we set the 0-position to 12288 counts. So by setting  $P5 = 100$  will result in the same position being :

$$P8 = (P7 - P6) + P5$$

$$P8 = (12288 - 12288) + 100$$

$$P8 = 100$$

Which again will be transferred to P\_IST and P\_SOLL if synchronization bit is set in the SSI-setup register at startup.

### 2.11.3 Registers used by SSI

Register 178, SSI\_SETUP\_BITS1 where:

Bit:	0	1	2	3	4 - 14	15
Function:	SSI Enable/Disable	Not used	Synchronize P_IST=P8, P_SOLL=P8	SSI reset position (P6=current position)	Future options	SSI Read Error

SSI enable will setup the motor to read the SSI at startup. The Synchronize bit transfers the position calculated in P8 into P\_IST and P\_SOLL.

SSI Reset position is used to preset a position to the value stored in P5. Default P5=0.

Bit 15=1 indicates a read failure, that is different values are read within the 4 times the values is read.

Register 57 P5	32-bit signed	Holds the preset value that is used when a reset position is done
Register 59 P6	32-bit signed	Holds the encoder value when the last Reset position was done. This value is used as a reference at startup to calculate the actual position.
Register 61 P7	32-bit signed	Holds the newly read encoder value, scaled into motor counts.
Register 63 P8	32-bit signed	Holds the calculated position, that is transferred to P_IST and P_SOLL if the synchronization bit is set up in the setup register 178.

## 2.11

# Using external SSI encoder

Only MAC050 to I4I

### 2.11.4 Encoder connections:

Using the LIKA rotary encoder MMC60 connected to the MAC00-B4 module the PIN configuration is as follows:

The encoder is connected to the IO-plug using the 8-pin female M12 -plug.

M12-Pin	Signal	Colour (LIKA Encoder cable)	Description
1	A+	White	Clock +
2	A-	Brown	Clock -
3	B+	Green	Data +
4	B-	Yellow	Data -
5	N.C	-	O1 from motor
6	O+	Red	24V supply to encoder
7	Gnd	Black + Shield	Gnd and shielding
8	N.C	-	

See Mac-manual for further details regarding the IO connection in the module.

Because the plug doesn't support a 24V power outlet, O1 or O2 can be used to supply the power to the encoder unit. To be able to do this register I6I needs to be setup. Bit 3 and bit 4 in register I6I indicates whether IO1 and IO2 are user controlled or setup as previously as IO1 indicating 'In position' and IO2 indicating errors.

*Example:*

IO2 is used as 24V power supply to the encoder so we need IO2 as user controlled output and set the output to source the O+ voltage.

Register I6I bit 4 needs to be on  
Register I6I = I6 (0xI0)

Register I79, bit0 and bitI holds the output value, but they are inverted so for IO2 to be high (O+) bitI needs to be 0.

So we hold the register to the default value I79 = 0 and IO2 will source power to the encoder.

When IO2 is on (O+), the red LED inside the motor is lit. This is normally used for error indication when the IO2 isn't setup for user control.

## 2.11 Using external SSI encoder

Only MAC050 to 141

### 2.11.5 Setup SSI using MacTalk

To setup the MAC-motor for reading the SSI encoder value at startup, first set the I/O setup for using SSI input. This means that the A and B input -channels are setup for input on both. Because the plugs doesn't support any 24V supply output for supplying the encoder, both IO1 and IO2 can be used for this purpose.

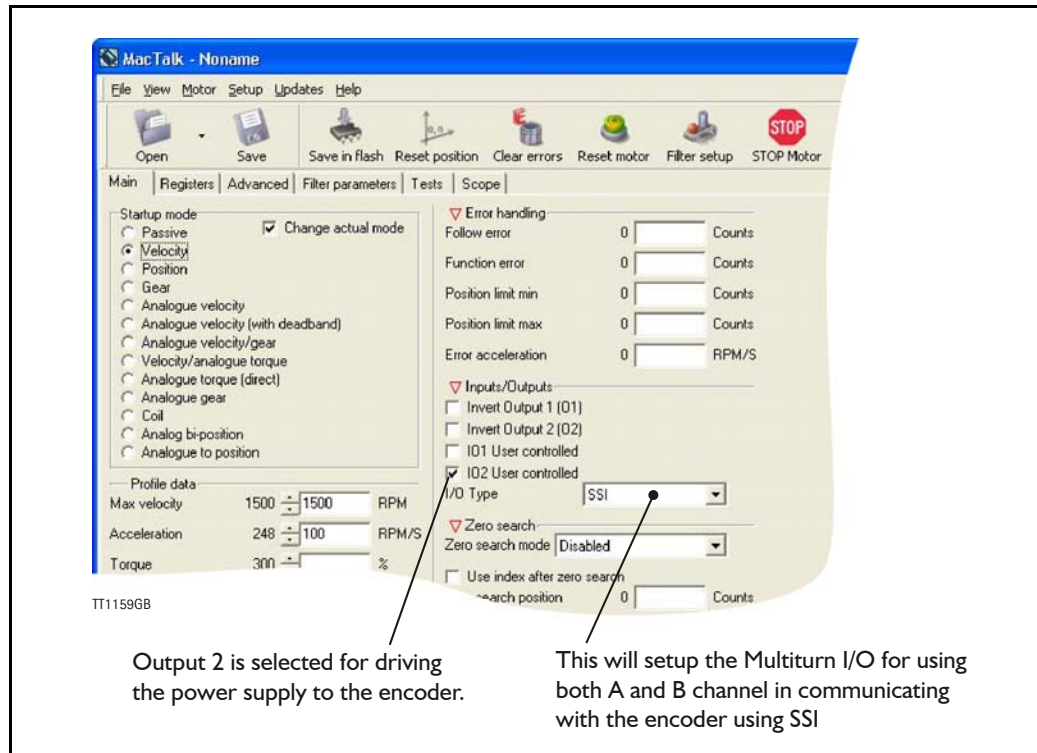

The screenshot shows the MacTalk software interface with the 'Advanced' tab selected. The 'Startup mode' section has 'Velocity' selected. The 'Error handling' section has 'Follow error' set to 0 Counts. The 'Inputs/Outputs' section has 'IO2 User controlled' checked and 'I/O Type' set to 'SSI'. The 'Profile data' section has 'Max velocity' set to 1500 RPM and 'Acceleration' set to 248 RPM/S. The 'Zero search' section has 'Zero search mode' set to 'Disabled'. Two callout boxes point to the 'IO2 User controlled' checkbox and the 'I/O Type' dropdown menu.

Output 2 is selected for driving the power supply to the encoder.

This will setup the Multiturn I/O for using both A and B channel in communicating with the encoder using SSI

#### SSI setup on the advanced tab.

This section gains access to the registers 178, for setting up the SSI functionality previously described.

The SSI position is stored in register P8, which is displayed under this section too. The value is also accessible from the register-tab.

#### Reset position procedure

To reset the motor to a specific position, first read the SSI encoder value by setting register 211 = 1

This will reset the motor and read the SSI value. Next set the Reset-bit in the SSI\_SETUP register (register 178 bit 3). Now the encoder value has been transferred to P6 and needs to be saved in flash. The Flash saving procedure is done by writing 211 = 2.

This will also reset the motor and calculate the new position based on the saved value. If a preset value is to be used instead of 0, this value is entered in P4 and will automatically be used when the motor starts up (previously explained).

If this preset value is to be used, simply write the position to position register P4 (register 55) and save the value to flash memory by writing 211 = 2.

#### Read SSI procedure.

Every time the motor is power cycled or a software is commanded the SSI encoder is read at startup.

To do a software reset simply write register 211 = 1 and let the motor startup. The reading and the startup will take approximately 1-2 seconds.

## 2.11 Using external SSI encoder Only MAC050 to I4I

---

### **I/O Setup**

Because of the strict timing in the motor it is not possible to read the encoder value when motor has started. This is due to strict timing control in the motor.

As a new feature the MAC40-I4I firmware now supports setting up IO1 and IO2 as user controllable. IO1 and IO2 is settable from these controls.

When all values has been setup, remember to save in flash and/or into a .mac file before removing power from the motor.

If an encoder is available on the motor, the actual position value is read as soon as the motor start-up after a reset.



### 2.12.1 Introduction

The absolute multi-turn encoder is an option with the MAC400, MAC402, MAC800, MAC1500 and MAC3000 motors.

The option offers the advantage that once the mechanical zero point is defined there will be no need for any *Zero search* or initialization sequence after power up since the motor always knows where it is with reference to the original defined zero point regardless that power have been removed for shorter or longer time.

Please notice that **ONLY** MAC400, MAC402, MAC800, MAC1500 and MAC3000 motors with the "F" extension contains this feature (MACxxx-yy-Fzzz).

The built-in multi-turn encoder is using a mechanical technology with the advantage that no battery is used to hold the position after power off. A battery needs replacement after a certain operating time or a certain number of charging and recharging cycles.

#### Basic encoder operation (default)

The encoder position is however locked to a specific mechanical zero position and a fixed position range. Therefore the encoder position can not be manipulated as flexible as for the standard encoder type since some upper and lower limits in the working range need to be respected in order to avoid overflow/wrap around issues during operation. The encoder position can maximum operate in the range from -2047 to +2047 mechanical revolutions.

The following pages describe the basic operation and how to set the zero point.

#### Extended encoder operation (selectable)

For applications that require a larger position range or applications that require that the motor position is still valid even if the maximum position range is exceeded the extended encoder operation can be selected.

The main advantage of the extended encoder operation is that the position range is 4 times higher and the overflow/wrap around is handled in a manner that the position data is still valid after any condition that would normally have caused the position data to be lost or invalid such as power cycling, reset or save in flash.

The full description of the extended encoder operation can be found in the section *Extended encoder operation - detailed description., page 70*

## 2.12 Absolute Multiturn Encoder

Only MACxxx-yy-Fzzz

### 2.12.2 How to setup the mechanical zero point (quick guide).

The tab “Absolute positioning” is visible in the MacTalk program when a motor with absolute multi-turn encoder is connected.

The functions showed below are used to adjust and monitor the actual encoder position.

Press “Save in flash” to store the modified encoder position permanent

Pressing the “Reset Position” button will reset the the absolute position (P\_IST)

Select this tab when adjusting the encoder position Usefull information exist here (see also later in his chapter)

MacTalk - Nname

File View Motor Setup Updates Help

Open Save Save in flash Reset position Clear errors Reset motor Filter setup STOP Motor COM scan

Main Registers Advanced File parameters Tests scope Absolute positioning

Absolute encoder position: -16777216 0 16777216

Encoder position: 97656

Position offset, encoder singulum resolution is 8192 Counts/Rev

Encoder offset: 0

Positive revs. before position wrap: 2048

Negative revs. before position wrap: 2048

Set offset = 0

Motor status:

Actual mode	Position
Actual velocity	0 RPM
Actual position	100000 Counts
Follow error	0 Counts
Function error	0 Counts
Actual motor torque	2 %
Motor load (mean)	6 %

TT1180GB

The Actual Position of the motor.

Physical position of the encoder. This value is not possible to change and must stay within +/-16.777.216 counts.

Make sure to clear any existing value (if any) in the offset register.

Procedure for adjusting the zero point:

1. Before mounting the motor in the application connect power to the motor.
2. Press the “Set offset = 0” button and move the motor until the “Encoder position” shows close to 0. This is recommended to make sure that the full encoder working range is available.
3. Mount the motor in the application and move it to the intended zero position.
4. Press the “Reset position” button to reset the “Actual position” (P\_IST) and press the “Save in flash” button in order to store the zero point setting permanent in the motor.

## 2.12 Absolute Multiturn Encoder

Only MACxxx-yy-Fzzz

### 2.12.3 How to stay within the encoder working range (detailed guide)

The motor is equipped with a offset register that holds an encoder position offset. When 24V power has been applied the motor will read the position from the encoder and set the actual shaft position according to this calculation:

$$\text{Absolute (motor) position (P\_IST)} = \text{Absolute\_Encoder\_Position} + \text{Encoder\_Offset}$$

So if the motor shaft is placed in position 1000 and the offset is set to -1000 the motor will set the actual position register (P\_IST) to 0.

The encoder has a limitation in the dynamic working range to be +/- 16.777.216 counts which corresponds to +/- 2048 shaft revolutions. Within this range the offset can be placed at any point but considerations regarding the wrap around of the position value must be made. Cycling 24V power for the motor when the shaft is placed in a wrapped position results in an unexpected position.

Example 1: The motor position has been reset when the Absolute\_Encoder\_Position was 16.000.000. This limits the positive working range to approx. 94 motor shaft revolutions which may cause an overflow and failure situation if the motor moves more than 94 revolutions during operation.

Example 2: Let's assume the motor has moved 100 revs. Placing the motor (MAC400) in the actual position = 819.200 counts.

Now the motor is reset (24V control power is cycled) the motor wakes up and reads the Absolute\_Encoder\_Position which in the mean time has been wrapped around to the position -16.735.232. Now the offset is used to calculate the actual shaft position of the motor:

$$\text{Actual (motor) position (P\_IST)} = -16.735.232 + (-16.000.000)$$

$$\text{Actual (motor) position (P\_IST)} = -32.735.232 !!$$

Which is not exactly what was expected because the encoder passed its working range.

## 2.12 Absolute Multiturn Encoder

Only MACxxx-yy-Fzzz

MacTalk visualize the encoder position in real time and makes the resetting far less complicated by displaying the actual encoder position and the free number of revolutions before reaching the wrap-around point of the encoder position.

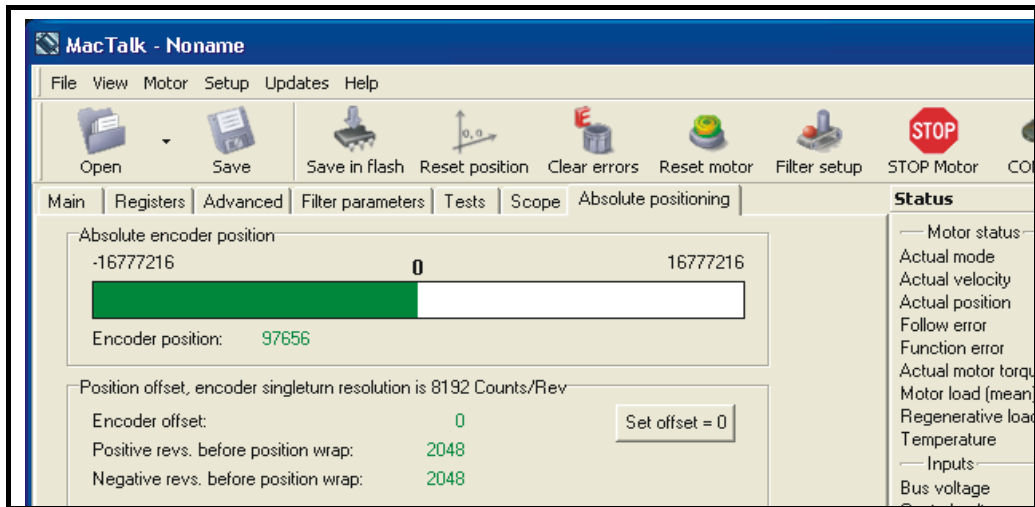

When the motor position is within -15.000.000 to 15.000.000 the encoder position bar is coloured green indicating a safe position for doing a position reset.

Outside this range the bar is coloured red indicating a range that is not recommended for position resetting the encoder position since it leaves a minor free working range. The free working range is displayed under the bar as positive and negative motor revolutions available before wrap-around.

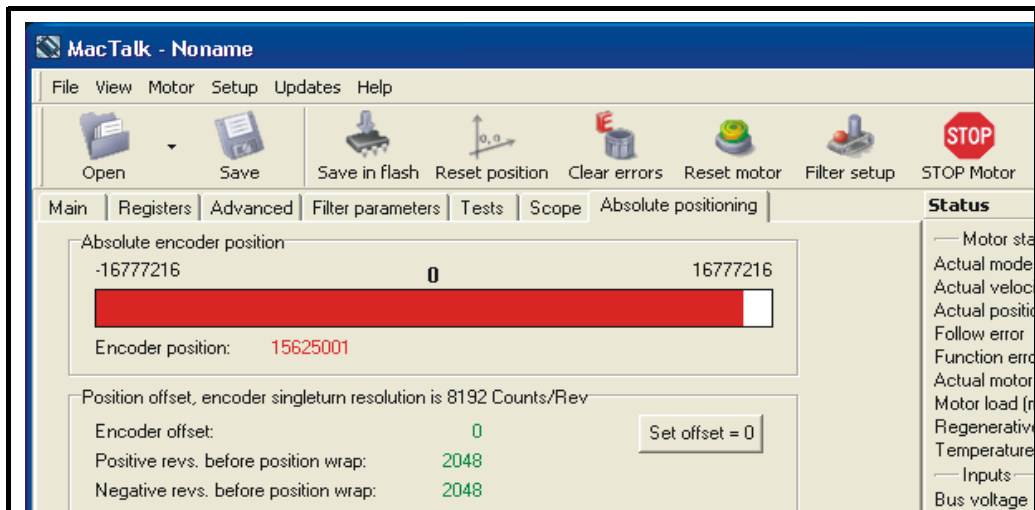

Of course resetting outside the recommended range is possible but care must be taken. Trying to reset the motor position in the red area results in a warning dialog that appears in MacTalk.

## 2.12 Absolute Multiturn Encoder

Only MACxxx-yy-Fzzz

### 2.12.4 For MAC800 users only:

Please observe the motor position scaling used. The motor resolution is by default 8000 counts/rev. The absolute build in encoder uses 8192 counts/rev. therefore scaling is done when the position is reset. This may cause some confusion since the actual shaft position is not the same as the absolute encoder position.

So with the motor in position mode, ordering a movement to motor position = 100.000 counts, results in a encoder position of 97.656 due to the larger encoder resolution (8192 counts/rev).

### 2.12.5 Resetting the position when not using MacTalk.

The procedure for adjusting the an encoder offset and thereby resetting a certain motor position to be zero position (Actual position = 0) is basically described in 4 steps:

1. Read register 226 which is the absolute encoder position value.
2. Multiply the position value (from above) by -1 (inverse the sign).  
Notice: that if "Inverted motor direction" is selected skip this step and proceed to step 3.
3. Store the value in register 225 which is the offset register.
4. Save the offset value permanently in the flash memory. This procedure is basically performed from the command register 211 by writing 211 = 2. When using a bus module please refer to the manual of actual type of bus module to do the save in flash operation. Please notice that if the value is not stored in the flash memory the zero point is lost after a power cycle.

#### For MAC800 users:

The MAC800 is default set to a resolution of 8000 counts/rev. compared to other motors which have 8192 counts/rev. as default.

The MAC800 default resolution can be changed from 8000 to 8192 by setting bit 21 to 0 in register 39 (HW\_SETUP). Default it is set to 1.

If the default has not been changed the 4 step procedure shown above can simply be used

If the default have been changed and the MAC800 is set to 8192 counts/rev. (bit 21 = 0)

1. Read register 226 which is the absolute encoder position value.
2. Register 225 =  $-(8192 * (\text{register } 226)) / 8000$ . Remember that the result must be negated before entering it into register 225.
3. Save the offset value permanently in the flash memory. This procedure is basically performed from the command register 211 by writing 211 = 2. When using a bus module please refer to the manual of actual type of bus module to do the save in flash operation. Please notice that if the value is not stored in the flash memory the zero point is lost after a power cycle.

## 2.12 Absolute Multiturn Encoder

Only MACxxx-yy-Fzzz

### 2.12.6 Extended encoder operation - detailed description.

As mentioned earlier in this chapter the encoder position is partly mechanical based and have a total resolution of  $\pm 2048$  mechanical revolutions.

When using the encoder in basic operation (default) the overall position counter will stay valid as long as the power is continuously applied to the motor and no reset is executed. If the power is cycled, the motor is reset or the parameters are saved in flash memory only position data in the range  $\pm 2048$  are kept valid.

When using the extended encoder operation any position outside the range  $\pm 2047$  will be saved in the flash memory before any event that will normally cause it to be lost. By doing this it is accomplished that the overall position counter is fully restored with the actual motor position after power up, reset or a save in flash operation.

Please notice that the position value can only be restored fully if the motor shaft has been moved less than  $\pm 2048$  revolutions during power off.

The full position range in the overall position counter is  $\pm 8192$  motor shaft revolutions. The resolution per revolution is default 8192 counts/rev.

### 2.12.7 Extended encoder operation - When using MacTalk.

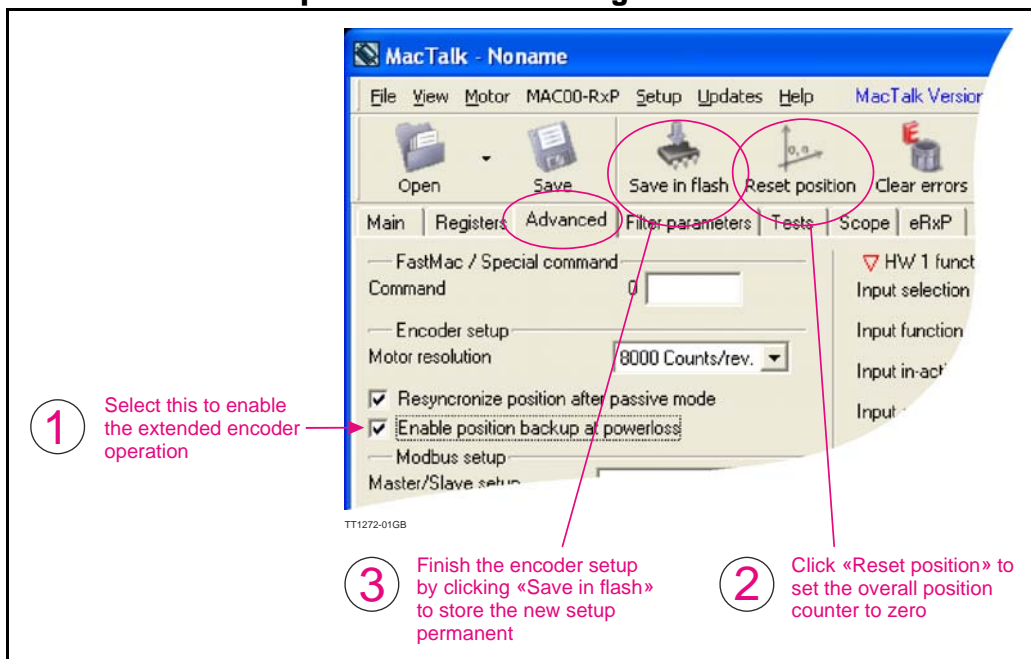

Following sequence is recommended for setup of the extended encoder operation.

1. Enable the extended encoder option at the “Advanced” tab.
2. Move the mechanics to the desired position where the zero point shall be and press “Reset position”. After doing this the actual motor position will be set to 0.
3. Finish the setup by pressing the “Save in flash” in order to store the settings permanently in the motor.

## 2.12

# Absolute Multiturn Encoder

Only MACxxx-yy-Fzzz

The actual position value of the motor can always be seen in the status area of MacTak as shown below.

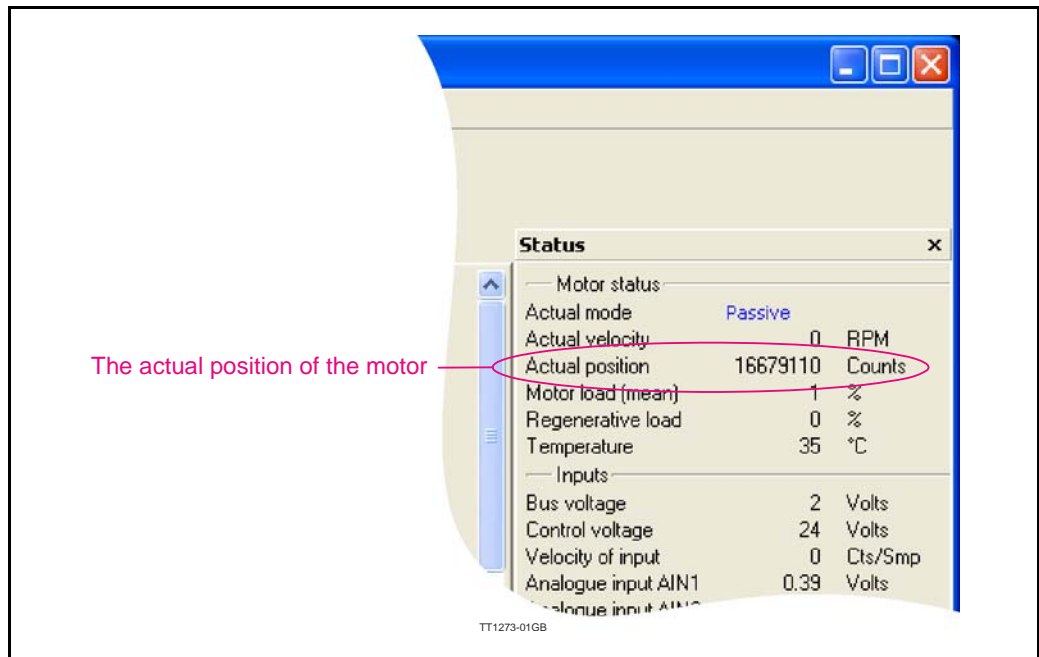

### 2.12.8 Extended encoder operation - When NOT using MacTalk.

The procedure for adjusting the an encoder offset and thereby resetting a certain motor position to be zero position (Actual position = 0) is basically described in 4 steps:

1. Set bit 7 in register 236 which will activate the extended encoder operation.
2. Write 0 or another position value to register 4 (P\_NEW). The actual motor position will preset to the value written here in the next steps of this sequence.
3. To actually preset the position value one of the following actions can be done  
Write 247 to register 211 (COMMAND) or alternatively set bit 6 in register 36 (CNTRL\_BITS) without changing the other bits.
4. Save the new settings permanently in the flash memory. This procedure is basically performed from the command register 211 by writing 211 = 2. When using a bus module please refer to the manual of actual type of bus module to do the save in flash operation.  
Please notice that if the value is not stored in the flash memory the zero point is lost after a power cycle and the extended encoder option will not be activated.

#### For MAC800 users:

The encoder resolution at the MAC800 with absolute multi-turn encoder is default 8192. The resolution can optionally be set to 8000 by setting bit 21 in register 39 (HW\_SETUP). Remember to save the change in flash memory according to step 4 shown above.

**2.12.9 Extended encoder operation - endless relative moves.**

In some applications the motor keeps moving in one direction with a certain length per move.

Since the position counter have a limited working range this kind of operation will sooner or later cause an overflow/wrap around situation.

To avoid the overflow/wrap around situation the actual motor position can be offset via a command. This offset can be done at any time without losing any position information. This feature is very helpful since the position counter will stay inside the working range.

Follow this setup sequence for doing a relative position offset:

1. To specify the offset distance write the desired offset distance (counts) to register 4 (P\_NEW).
2. To actually offset the position value, one of the following actions can be done
  - Write 248 to register 211 (COMMAND) or alternatively...
  - Set bits 6 and 8 in register 36 (CNTRL\_BITS) without changing the other bits. This will add the value given in point 1 above to both the actual position and the target position.

To actually perform a relative movement, there are two safe options and one not so safe/precise.

**Option 1, relative moves using P\_SOLL.**

1. Prepare for relative movements using register 3 (P\_SOLL) by executing FastMac command 117 (96+21). This only has to be done once after start up. It selects what will happen when a position register, one of P1 through P8, is activated by a FastMac command.
2. Prepare the relative distance to move by writing it to one of the general purpose P1 through P8 position registers.
3. Execute a FastMac command that 'activates' the Px register. See the section for your specific MAC00-xx interface module on how to execute FastMac commands.

This type of relative movement will set  $P\_SOLL$  (target position) =  $P\_IST$  (actual position) + Px in a safe way that avoids the type of error described in option 3 below. Note that P\_SOLL and P\_IST will sooner or later exceed the operating range if this method is used repeatedly, so you will need to use the relative position offset method described for the absolute encoder in Extended Encoder operation.

**Option 2, relative moves using P\_FNC.**

1. Prepare for relative movements using P\_FNC by executing FastMac command 118 (96+22). This only has to be done once after start up. It selects what will happen when a position register, one of P1 through P8, is activated by a FastMac command.
2. Prepare the relative distance to move by writing it to one of the general purpose P1 through P8 position registers.
3. Execute a FastMac command that 'activates' the Px register. See the section for your specific MAC00-xx interface module on how to execute FastMac commands.

This type of relative movement will not change PSOLL, so no wrap-around handling is needed.



## 2.12

# Absolute Multiturn Encoder

Only MACxxx-yy-Fzzz

### Option 3 (the unprecise one):

Write a value to the target position register 3 (P\_SOLL) that is the actual position plus/minus the distance to move. This is unsafe/inaccurate because the actual position may have changed in the time it took to read the value, do the calculation and write back the new target position. This may still work on some applications, or even be desirable, but note that a position error might accumulate over time.

In some applications, it may be useful to prepare several position distances in the different P1 through P8 registers, and then activate them using different FastMac commands.

### 2.12.10 RxP programing - Resetting the position to 0

If a RxP program is resetting the encoder zero point it must be done as follows.

When the “invert motor direction” **IS NOT** enabled the offset can be changed by this formular:  $\text{Abs.Enc.Offset} = 0 - \text{Abs.Enc.Pos.}$

When the “invert motor direction” **IS** enabled the offset can be changed by this formular:  $\text{Abs.Enc.Offset} = 0 + \text{Abs.Enc.Pos.}$

Following examples show how to make program commands for resetting the position. Please notice that the “Set special command to 2” (line 7 and line 12) will save the new encoder offset value in order to make it effective and the motor will be reset and restart.

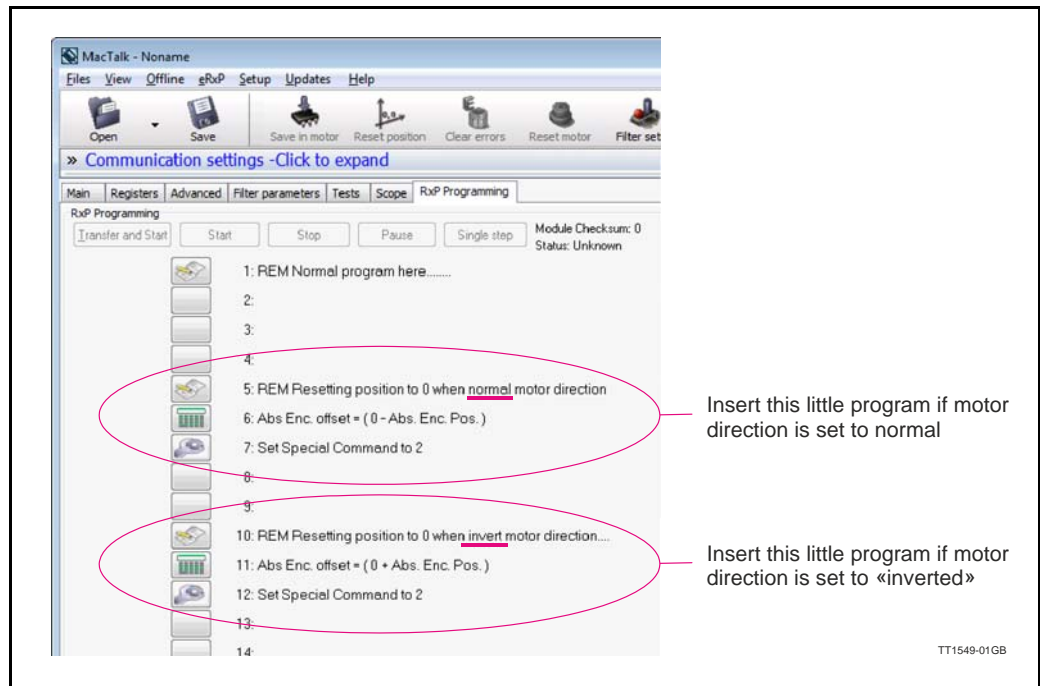

The screenshot shows the MacTalk software interface with the RxP Programming tab selected. The main window displays a list of 14 program lines. Two specific programs are highlighted with red ovals and annotated with text:

- Line 5: REM Resetting position to 0 when normal motor direction
- Line 6: Abs Enc. offset = ( 0 - Abs. Enc. Pos. )
- Line 7: Set Special Command to 2
- Line 10: REM Resetting position to 0 when invert motor direction...
- Line 11: Abs Enc. offset = ( 0 + Abs. Enc. Pos. )
- Line 12: Set Special Command to 2

Annotations on the right side of the screenshot:

- For lines 5-7: Insert this little program if motor direction is set to normal
- For lines 10-12: Insert this little program if motor direction is set to «inverted»

TT1549-01GB

## 2.13

# Rotary table option

---

### 2.13.1 General description

The Rotary table option, also sometimes called Dividing head, Indexing table or turntable option, makes the motor work in three different ways that limits the actual position and target position to a smaller position range than normal. This is useful for supporting some mechanical systems.

One of the strong features of this is the motor's ability to calculate the shortest movement to a new target position automatically.

The option can also be used to have the motor always move in the same direction for any target position value even if the new target position value is below the old position in this case the motor will turn in the configured CW or CCW direction until it returns to the lower target position.

The actual position will not overflow even when always running in the same position for any length of time.

The general idea is to define a range of positions by a Minimum and a Maximum value that can be freely selected within the normal position range of the motor (-67 million count to + 67 million counts). Whenever the actual position exceeds the maximum it will wrap around and continue from the minimum position while still running in the same direction.

Also when moving below the minimum position it will wrap around and continue to count down from the maximum position.

During operation the motors main operation mode is usually set to Position mode (MODE\_REG = 2), and the motor is commanded to a new target position by writing a new value to the Target Position, register 3, P\_SOLL. See also - *Modes other than Position mode, page 79*.







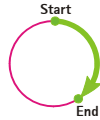
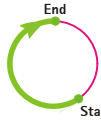

The value written to P\_SOLL should be within the rotary table position range. If the value is outside the working range specified by "Turn table pos. min." or "Turn table pos. max" it will be clipped to be within the values specified by "Turn table pos. min." or "Turn table pos. max". To make a full turn in CW or CCW mode, a multiturn operation is supported see following illustration. The registers normally used for software position limits are used to define the rotary table working range in rotary table operation.

(Continued next page)

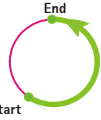
## 2.13

## Rotary table option

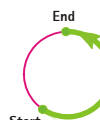
The 5 operation options for the Rotary Table operation are shown in the following scheme:

<b>Basic setup:</b> Working range min./max= 0 to 7999 counts equal to one revolution. Examples based on MAC800	<b>Situation 1</b>	<b>Situation 2</b>
<b>1</b> Singleturn CW rotation	 <p>Setup : Start position 0 Target position = 3000</p>	 <p>Setup : Start position 3000 Target position = 0</p>
<b>2</b> Singleturn CCW rotation	 <p>Setup : Start position 0 Target position = 5000</p>	 <p>Setup : Start position 5000 Target position = 0</p>
<b>3</b> Shortest path	 <p>Setup : Start position 0 Target position = 3000</p>	 <p>Setup : Start position 0 Target position = 5000</p>
<b>4</b> Multiturn CW rotation	 <p>Setup : Start position 0 Target position = 19000 Result: P_SOLL = 3000 since the remainder after 19000 / 8000 is 3000.</p>	 <p>Setup : Start position 3000 Target position = -1000 Result: Actual position (P_SOLL) = 0 since the value is limited to the working range minimum</p>
<b>5</b> Multiturn CCW rotation	 <p>Setup : Start position 5000 Target position = 12345 Result: Actual position (P_SOLL) = 7999 since the value is imited against the working range maximum</p>	 <p>Setup : Start position 0 Target position = -21000 Result: P_SOLL = 5000 since the remainder after 21000 / 8000 is 5000.</p>
<p>Note 1: In general, Actual position (P_SOLL) will be modified to be within the valid rotary table position working range if a value outside this range is written to the Actual position register (P_SOLL).</p> <p>Note 2: When using the multiturn options (4 and 5) the position is limited as follows:</p> <ul style="list-style-type: none"> <li>- Multiturn CW rotation (4). Values below working range minimum are limited to the minimum.</li> <li>- Multiturn CCW rotation (5). Values above working range maximum are limited to the maximum.</li> </ul> <p style="text-align: right;">TT1186GB</p>		

## 2.13 Rotary table option

### 2.13.2 Configuration via MacTalk.

When using MacTalk for configuration the following parameters are used:

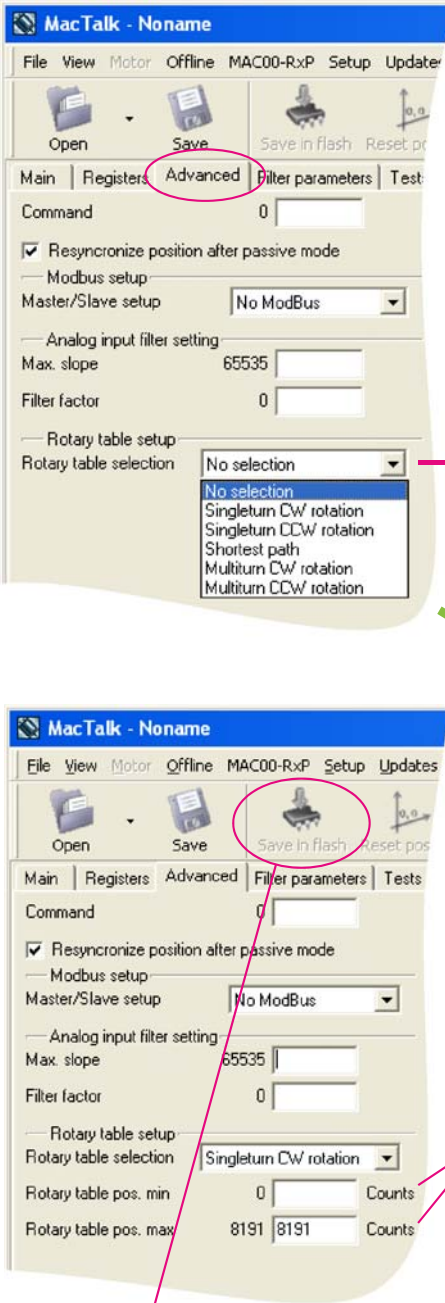

The image contains two screenshots of the MacTalk software interface. The top screenshot shows the 'Advanced' tab selected, with a dropdown menu for 'Rotary table selection' open, listing options like 'No selection', 'Singleturn CW rotation', 'Singleturn CCW rotation', 'Shortest path', 'Multiturn CW rotation', and 'Multiturn CCW rotation'. A pink arrow points to this menu with the text: 'The desired Turn Table Mode is selected here at the Advanced tab'. The bottom screenshot shows the 'Filter parameters' tab selected, with a pink circle around the 'Save in flash' button. A green arrow points from the top screenshot to this button. Below the screenshots, a pink arrow points to the 'Rotary table pos. min' and 'Rotary table pos. max' fields, which are set to 0 and 8191 respectively. A text box explains: 'The working range can be defined here after selecting the type of turn table mode. Minimum is the lowest position possible to reach and maximum is the highest position that can be reached. Both in encoder counts. Both values are referring to the zero position found during the optional zero search or alternatively the zero point defined if using an absolute multiturn encoder.'

After the setup is done please remember to save it in the permanent memory by pressing the *Save in motor* button.

TT1185GB

## 2.13

# Rotary table option

### 2.13.3 Configuration via motor registers.

When the configuration is done by channels other than MacTalk such as Ethernet, Profibus, CAN-open etc. or just a simple interface connection to the basic motor the following description must be followed.

The main rotary table operation is selected by bits 24 and 25 in Register 39, HW\_SETUP. An addition the option to support multiturn rotary table operation is selected by bit 26 in Register 39, HW\_SETUP.

#### Register 28, MIN\_P\_IST

Holds the minimum position for the rotary table working range.

#### Register 30, MAX\_P\_IST

Holds the maximum position for the rotary table working range.

Note that the firmware will swap the min. and max. values if the minimum is larger than the maximum at startup.

#### Register 39, HW\_SETUP

Bits 24, 25 and 26 only. The value of bits 25 and 24 define the rotary table options:

Bit 26	Bit 25	Bit 24	Operation selected
0	0	0	No Rotary table operation (normal motor operation with full position range)
0	0	1	Always CW rotary table operation.
0	1	0	Always CCW rotary table operation.
0	1	1	Shortest path rotary table operation.
1	0	0	Illegal setting.
1	0	1	Always CW rotary table operation with multiturn operation.
1	1	0	Always CCW rotary table operation with multiturn operation.
1	1	1	Illegal setting.

Bit 26 in register 39, HW\_SETUP, select the multiturn operation. This bit is used only with the CW and CCW operations and allows complete turns to end at the same mechanical position as it started from by specifying a target position, P\_SOLL, that lies outside the rotary table position range. For instance, if the working range is 0..7999 (a range of 800 valid positions, one full motor shaft revolution on the MAC800) and the current target position is at 3000 writing 11000 (3000 + 8000) will make the motor perform exactly one full turn and leave both P\_SOLL and P\_IST\_TURNTABLE at 300 afterwards.

In general, P\_SOLL will be modified to be within the valid rotary table position working range if a value outside this range is written to P\_SOLL.

**Important:** Please remember to save the setup in permanent memory (save in flash) before the setup is applied and used by the motor.

## 2.13

# Rotary table option

### 2.13.4 Status read out via MacTalk.

When status read out is done via the MacTalk program data is presented as follows:

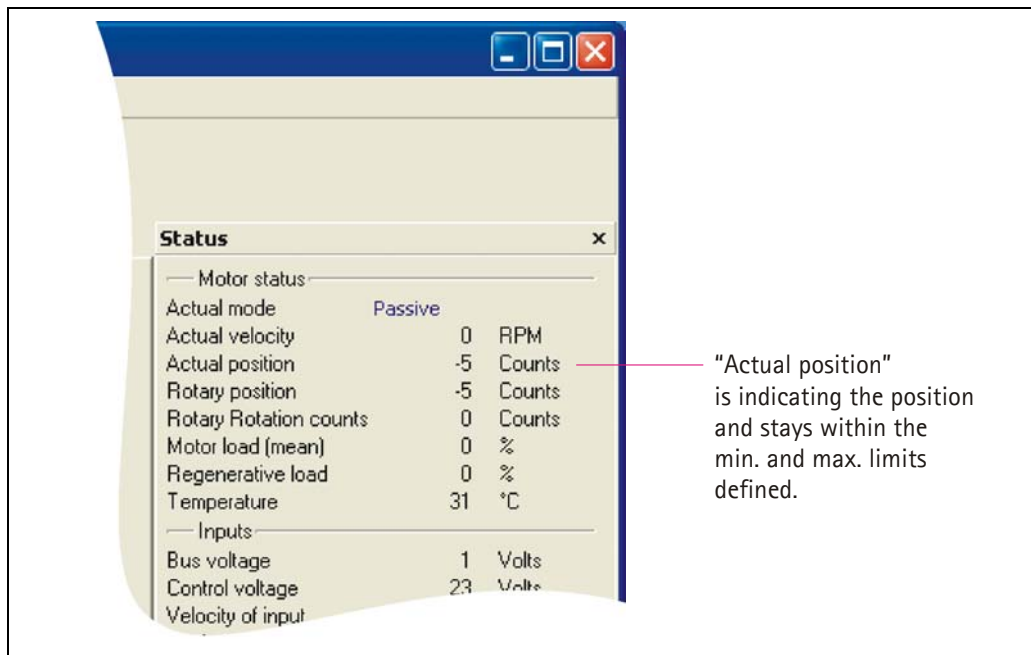

"Actual position" is indicating the position and stays within the min. and max. limits defined.

### 2.13.5 Status read out via motor registers.

When status read out is done by channels other than MacTalk such as Ethernet, Profibus, CAN-open etc. or just a simple interface connection to the basic motor the following description must be followed.

#### Register 25, P\_IST\_TURNTABLE

Holds the actual position within the rotary table working range.

#### Register 27, TURNTAB\_COUNT

Is a counter that keeps track of wrap-arounds since the last reset of the motor. This register can be written to another value by the user at any time.

#### Register 10, P\_IST

Is still the 'real' actual position 'inside' the motor but should generally not be used in rotary table operation. P\_IST will be modified by the firmware as a result of writes to P\_SOLL.

### 2.13.6 Rotary table notes

#### - Start up positions.

Normally the motors will start up with a zero value in P\_IST and P\_SOLL when using a standard encoder or with the position read from an absolute encoder (possibly offset by the P\_OFFSET register).

In case the rotary table position range does not include the start up value, the start up value is modified by adding or subtracting N times the number of valid position in the rotary table position range until it is inside this range.

### - Valid position range.

Whenever the motor needs to perform a wrap-around it moves the value of P\_IST outside the valid rotary table position range.

For normal operation, without multi-turn:

When operation “Always CW” is selected P-IST can temporarily be moved up to one full working range below MIN\_P\_IST.

When operation “Always CCW” is selected P-IST can temporarily be moved up to one full working range above MAX\_P\_IST.

With Shortest Path, P\_IST can be moved both one full working range above MAX\_P\_IST or below MIN\_P\_IST.

When setup for operation as either “Multiturn CW rotation” or “Multiturn CCW rotation” the number of ranges P\_IST can temporarily move outside the working range depends on the value written to P\_SOLL and will be the number of full turns required plus one. This is important to keep in mind if it causes P\_IST to exceed the motors absolute position working range of -67 million to + 67 million.

### - Modes other than Position mode

With the HW\_SETUP bits 24 and/or 25 set main motor modes other than Position mode also work slightly different.

The software position limits do not cause the motor to go into Passive mode if/when P\_IST exceeds any of these limits.

Register 25, P\_IST\_TURNTAB is still updated to show the actual position relative to the rotary table position range - even while P\_IST gets outside MIN\_P\_IST or MAX\_P\_IST.

One common way to do manual adjustment of the motor is to make a JOG function by using Velocity mode. After a JOG function the P\_IST may be left outside the rotary table position range, so switching back to Position mode may cause the motor to move 'unexpectedly'. It is generally recommended to set the maximum velocity V\_SOLL, to zero when exiting a JOG operation and update P\_IST and P\_SOLL to desired values before setting V\_SOLL back to a non-zero value.

### 2.14.1 Power Save

The MAC50-I4I firmware supports a function to save power in Position mode and Analogue bi-position mode that can automatically set the motor into Passive mode during pauses in movements, and restore the original mode when a new movement is required.

This can be useful for battery powered applications as well as general power and cost savings and to reduce audible and electrical noise.

The power save function is enabled when bit 0 in register I80, SETUP\_BITS, is set to one.

When Power Save is enabled, the motor is set into Passive mode after the actual position has been within the In Position Window for one second. This position, where Passive mode was entered, is then remembered, and as soon as the actual position gets farther from the remembered position than the value in the In Position Window register, the motor is set back into the original Position or Analogue bi-position mode.

#### **Cautions.**

When Power Save is enabled, some functions may work differently from what is expected. For instance, in Analogue bi-position mode, changing the Low or High Position values will not have effect until the motor is set back into active mode by turning the axis or re-selecting the active mode.

Also with under-voltage conditions, where the motor is set to enter Passive mode and restore the original mode when the voltage gets back to normal, can leave the motor in Passive mode, so in this case under-voltage handling should rather set an error bit that should be monitored.

In some tricky cases, when the motor is Power Saved and the axis turns very slowly away from the saved position, the motor will stay in Passive mode until the actual position has moved twice the distance that is stored in the In Position window register. This happens because the motor initially wakes up at the correct distance, but will re-enter Passive mode immediately because it was not outside the In Position window long enough to resume the original active mode. This issue can be reduced by selecting a better value for the In Position window register.



## 2.15

# Scope Function

### 2.15.1 Scope Function

Preliminary - this function is still under development.

The Scope function is a 4 channel oscilloscope that is, a very good and necessary function for testing a new application or finding errors in an existing system.

The Setup has to be selected to set up the Scope function correctly before use. Most registers in the MAC motors can be chosen for viewing, different trigger functions can be selected, saving and loading scope pictures are possible etc.

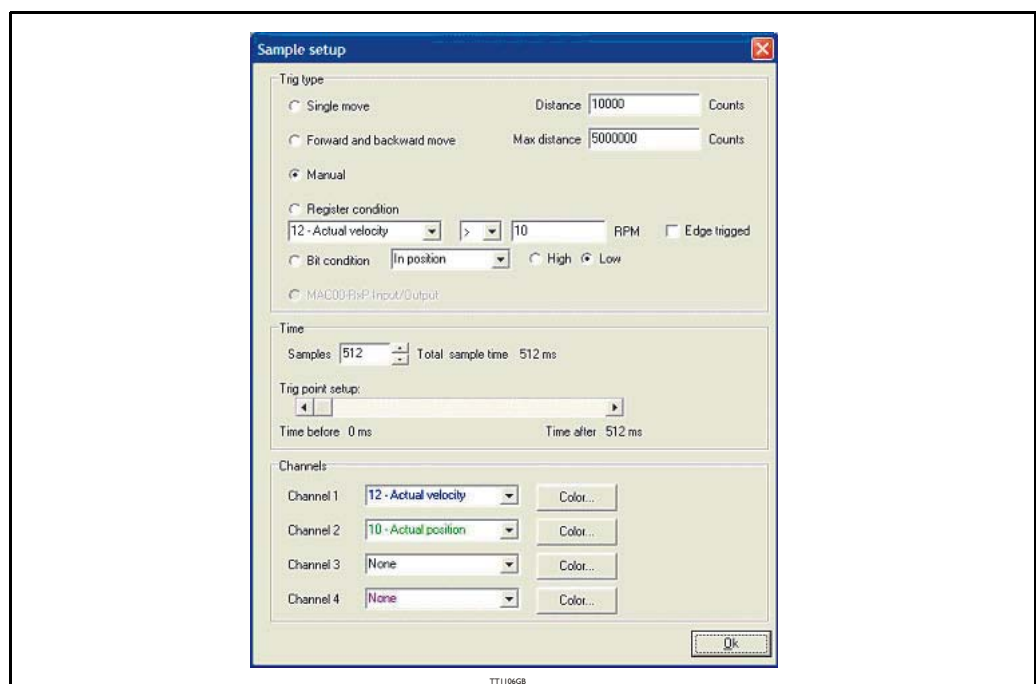
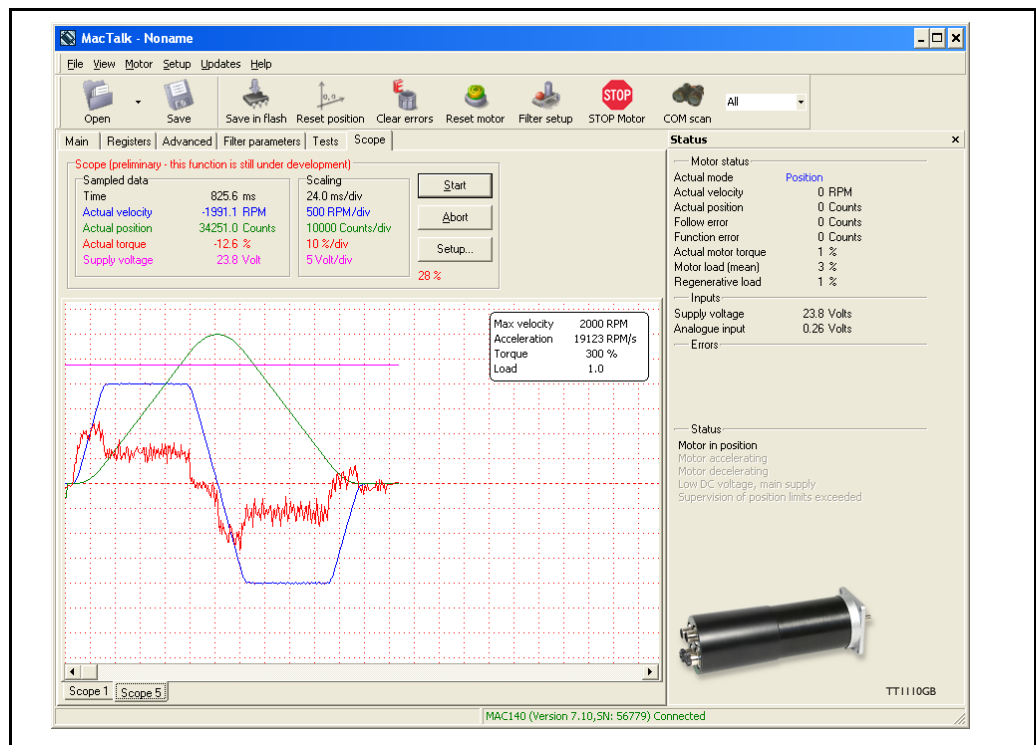

### 2.16.1 Introduction to the STO function.

The STO function can be used for disabling the energy to the motor. The motor will thereby be set in a state where it produces no torque.

The STO function have its own input connector mounted at the front of the motor. It is a 2 input system and it is required that both inputs are activated (applied with a voltage) before the motor is energized and can operate normally.

The STO is only available on following products MAC400, MAC I 500, MAC3000 in the standard versions.

The STO input connector is placed as shown below. The illustration is based on the MAC400 motor but the STO connector is placed similar at the MAC I 500 and MAC3000.



#### Important general information:

- The STO function is not approved by any third party laboratory (only pending)
- Please notice that removing the energy from the motor by use of the STO function do not necessarily stop the motor rotation since any attached load inertia will have an influence when the movement is stopped fully.
- The person that install and service the motor must have a general knowledge concerning electrical equipment and safety functions.
- The STO function is considered as functional and reliable for 20 years.

## 2.16

# Safe Torque Off (STO)

Only MAC400,1500&3000

### 2.16.2 How to connect and use the STO function.

The STO connector contains the 2 enable inputs STOA and STOB. Both inputs must be applied nominal +24VDC in order to energize the motor and make any motor movement possible.

If only one of the inputs is not applied +24VDC the internal STO circuit will remove the energy from the motor.

The illustration below shows the pinout of the connector.

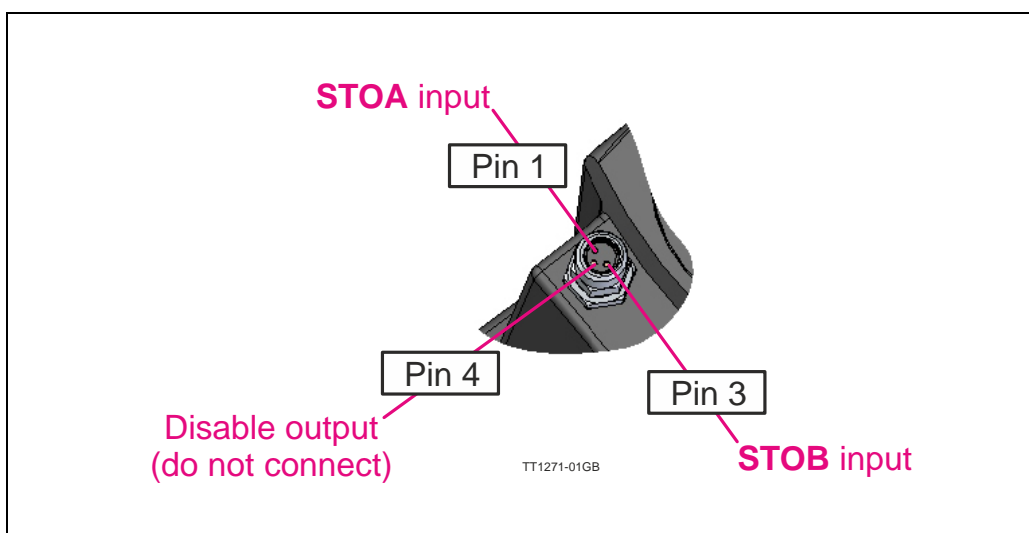

### 2.16.3 Disabling the STO function.

If the STO function is not needed the plug JVL type **W11010-M08M3SSTO** must be inserted in the STO connector.

The need of this external plug to disable the STO function is to obtain a high safety level and make sure that no misunderstandings will occur concerning whether the STO function is active or not.

### 2.16.4 STO cabling.

JVL offers a standard 5m long cable with 3 pin M8 connector in one end and flying leads in the other end.

The part no. is **W11010-M08M3T05P**.

### 2.16.5 Behaviour of the motor operation if STO is activated

When one or both of the STO signals are removed it will force the motor in passive mode and an STO error will be shown.

Also the busvoltage readout will show a bus voltage of exactly 100VDC which indicates that the STO has been activated.





## 3.1

# Connector overview

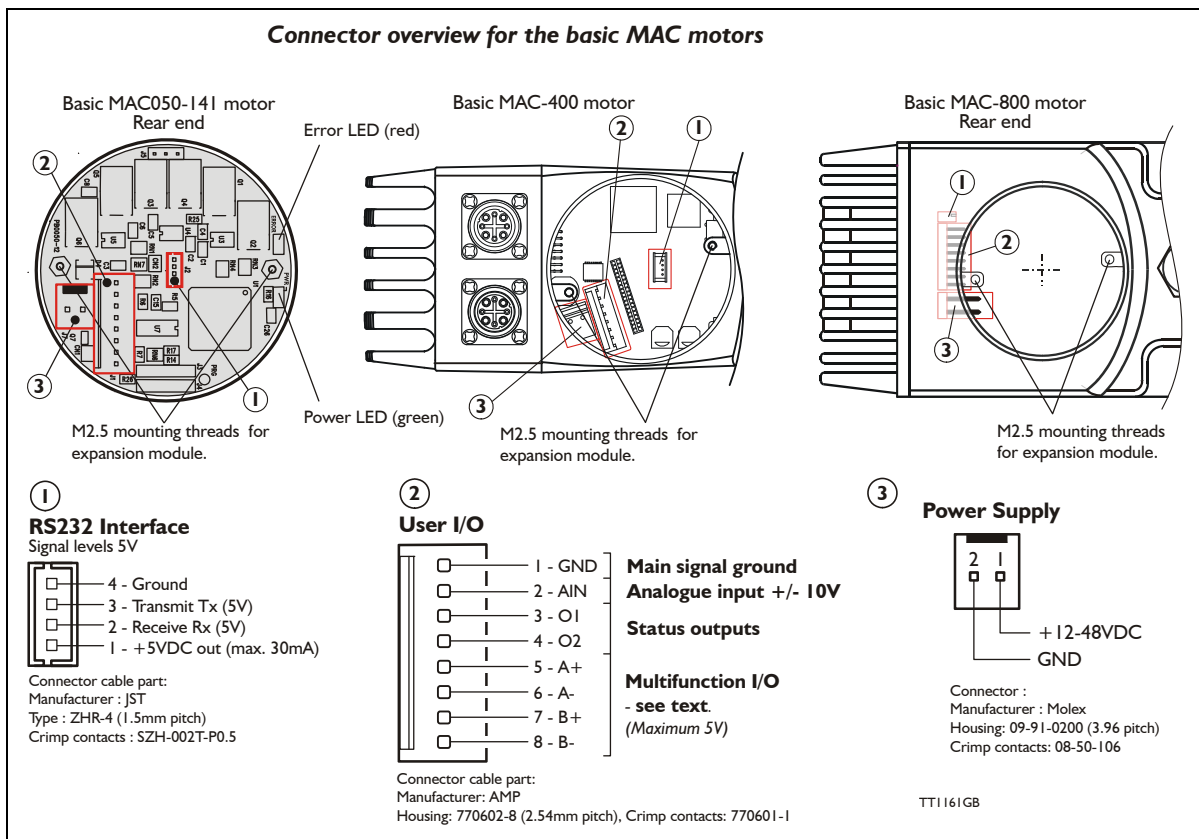

### 3.1.1 Connector description

The basic MAC motor is equipped with 3 connectors.

#### - RS232 Interface

The motor setup and monitoring is done via this interface. The windows-based *MacTalk* software must be installed on a computer and used for this purpose. It is also possible to send position, velocity and other commands from, for example, a PLC if *MacTalk* is not used.

#### - User I/O

This connector includes all the main I/O necessary to run the motor in gear mode, velocity mode, etc. An analogue input ( $\pm 10V$ ) can be used for velocity or torque control or it can be used for a *Zero search* sensor. 2 Status outputs are also available to show the actual status of the motor. Terminals 5 to 8 are multifunction terminals, where the specific function of the terminals depends on the motor setup.

The functions can be *only one* of following:

1. Pulse outputs. The internal encoder-pulses are output as a quadrature signal.
2. Pulse inputs. e.g. an external encoder can be connected for gearing applications.
3. RS422 communication. This interface is intended for permanent connection.

#### - Power Supply

Connect the main supply to this connector. The voltage must be within the range 12 to 48VDC nominal. Please note that the MAC400 and 800 only accepts +18 to 30 VDC. For further information about the MAC400 and 800 main supply, See *How to connect power supply (only MAC400)*, page 91 and *How to connect the power supply (only MAC800)*, page 100.

A connector kit is available "MAC00-CONKIT1". See *Accessories*, page 415.

## 3.2

# Power Supply

Only MAC050 to 141

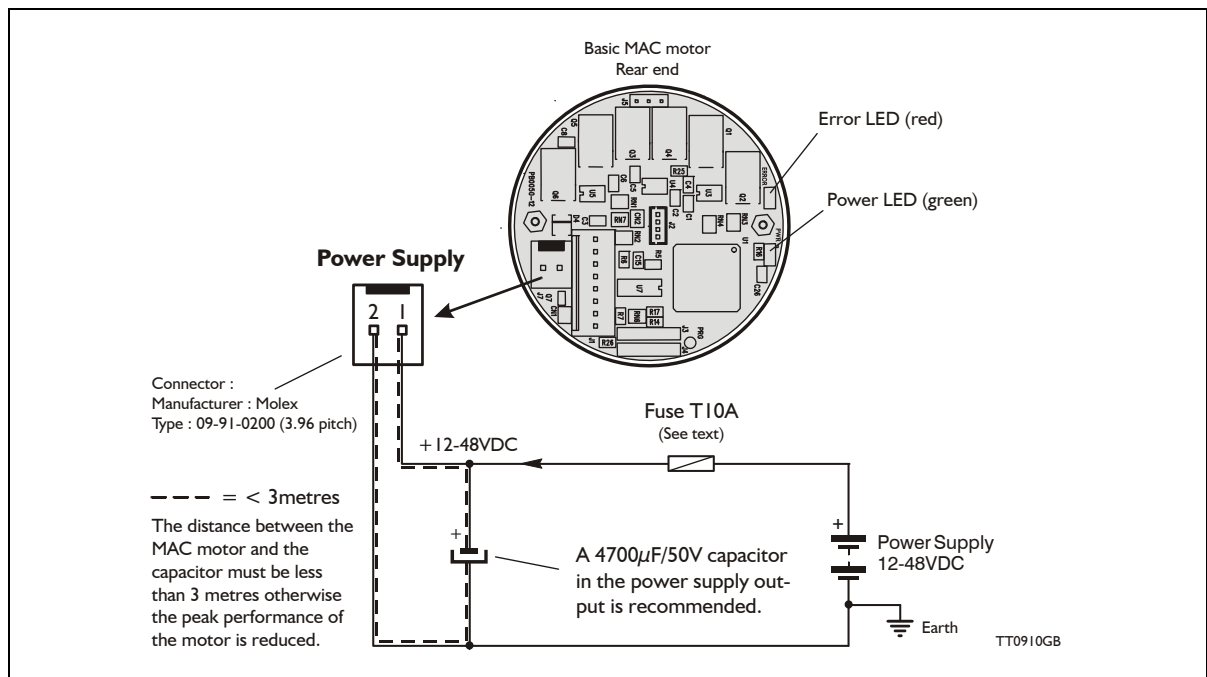

### 3.2.1 Power supply (only MAC050 to 141)

The power supply must be connected to the terminals marked +48V and GND. The supply voltage can be in the range 12VDC up to 48VDC; however the maximum speed of the motor (4000 RPM) is based on 48VDC. A lower voltage will decrease speed performance.

This curve below shows the relationship between voltage and recommended speed.

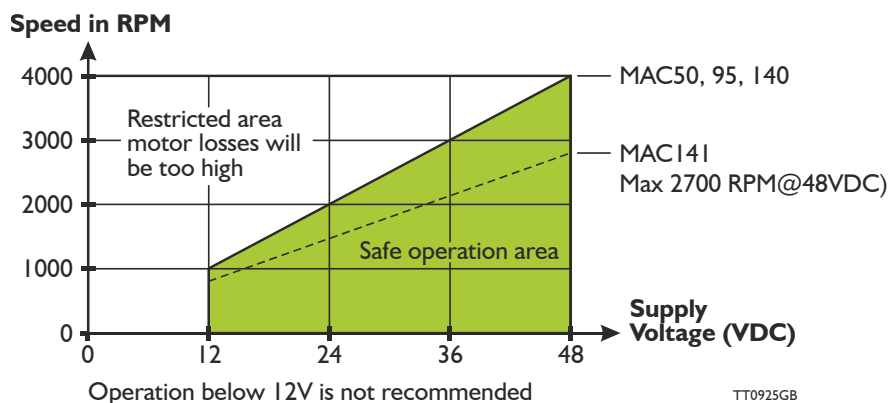

If a supply voltage lower than 48VDC is used, it will not influence the motor torque unless the corresponding speed at this voltage is overridden. The MAC motor continuously measures the actual supply voltage and optimises the current control filter. This feature ensures that the motor always produces full torque within the safe area of operation.

### 3.2.2 Power supply grounding (only MAC050 to 141)

No additional grounding/earthing of the motor is necessary since the complete motor housing is connected directly to pin 2 of the Power Supply connector. The overall earthing of the system must be done at a central point close to the power supply.

## 3.2

# Power Supply

Only MAC050 to 141

### 3.2.3 Dimensioning power supply and fuse (Only MAC050 to 141)

The power supply must be dimensioned according to the actual motor size (MAC050, 95, or 140/141).

The size of the pre-fuse also depends on the actual model of the MAC motor.

Use the following table to select the power supply and fuse ratings.

Desired voltage	MAC050		MAC095		MAC140 or 141	
	Supply rating	Fuse size	Supply rating	Fuse size	Supply rating	Fuse size
-	20W	T4A	40W	T6.3A	60W	T10A
12VDC	20W	T4A	40W	T6.3A	60W	T10A
24VDC	40W	T4A	80W	T6.3A	160W	T10A
48VDC	80W	T4A	160W	T6.3A	320W	T10A

See also *Power Supplies, page 416* in the appendix which shows the standard power supplies that JVL can offer.

### 3.2.4 Emergency stop

Please consult the chapter: *Emergency stop considerations, page 360*



## 3.2

# Power Supply

Only MAC050 to I41

### 3.2.5 Estimating the peak current from the supply.

The peak current drawn from the DC power supply is dependant on the following parameters:

- Maximum motor speed
- Maximum load torque
- Supply voltage used

The calculation is done as follows:

**Conditions** (example)

Maximum speed = 2500 RPM = 262 Radians/sec.

Maximum torque = 0.9 Nm (peak torque) @ MAC I40 is used with 300% (full torque)

Supply voltage = 24VDC nominal

Worst case efficiency of the MAC50-I41 motors = 0.8 (80%)

**Power calculation:**

Power = (speed x torque)/efficiency =  $(262 \times 0.9)/0.8 = 295\text{W}$

**Current calculation:**

Current at peak torque = power / supply voltage =  $295/24 = 12.3\text{Amp.}$

Please note that the peak current is only at maximum during for example an acceleration or deceleration. The peak current can be reduced if the "Torque" setting is lowered. The peak current will decrease proportionally with the Torque setting.

Example : Half torque = half peak current.

The below curve shows how the power and current are behaving as a function of the motor speed during acceleration, constant speed and deceleration.

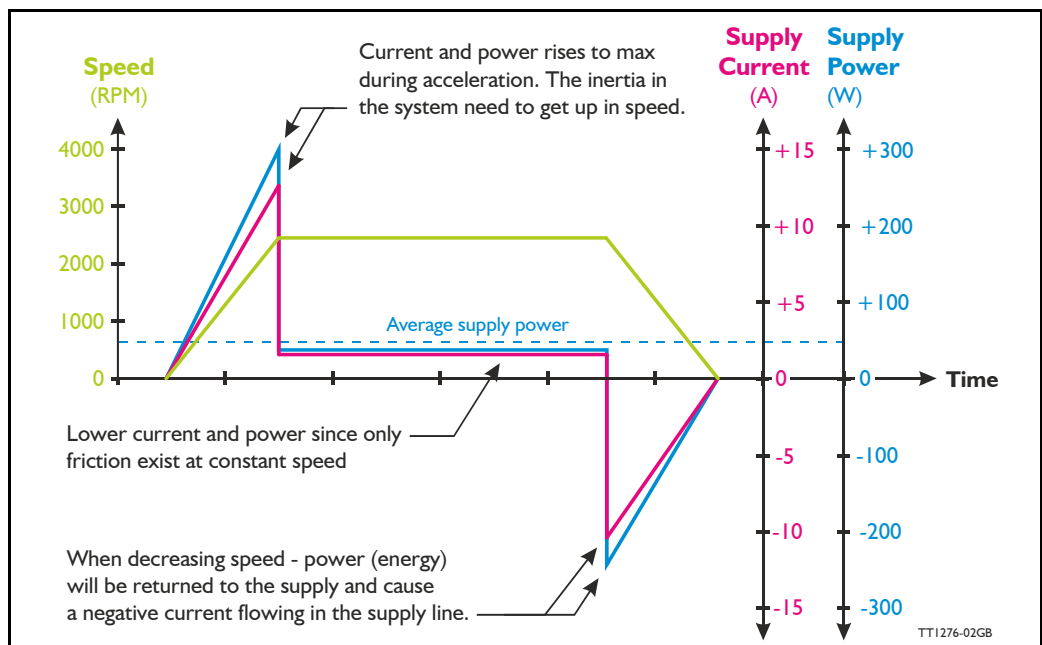

## 3.2

# Power Supply

Only MAC400

### 3.2.6 Power supply circuitry (only MAC400)

The MAC400 supply is split into 2 individual circuits with full galvanic isolation between the circuits. The control circuitry requires a voltage in the range 18 to 30VDC and the power circuitry must be supplied with 90 to 240VAC. Having 2 independent supply circuits offers the feature that the supply voltage for the power circuitry (90-240VAC) can be removed for safety reasons, while the control circuitry can continue operating and thus keep the position counter updated and keep other vital functions such as communication active.

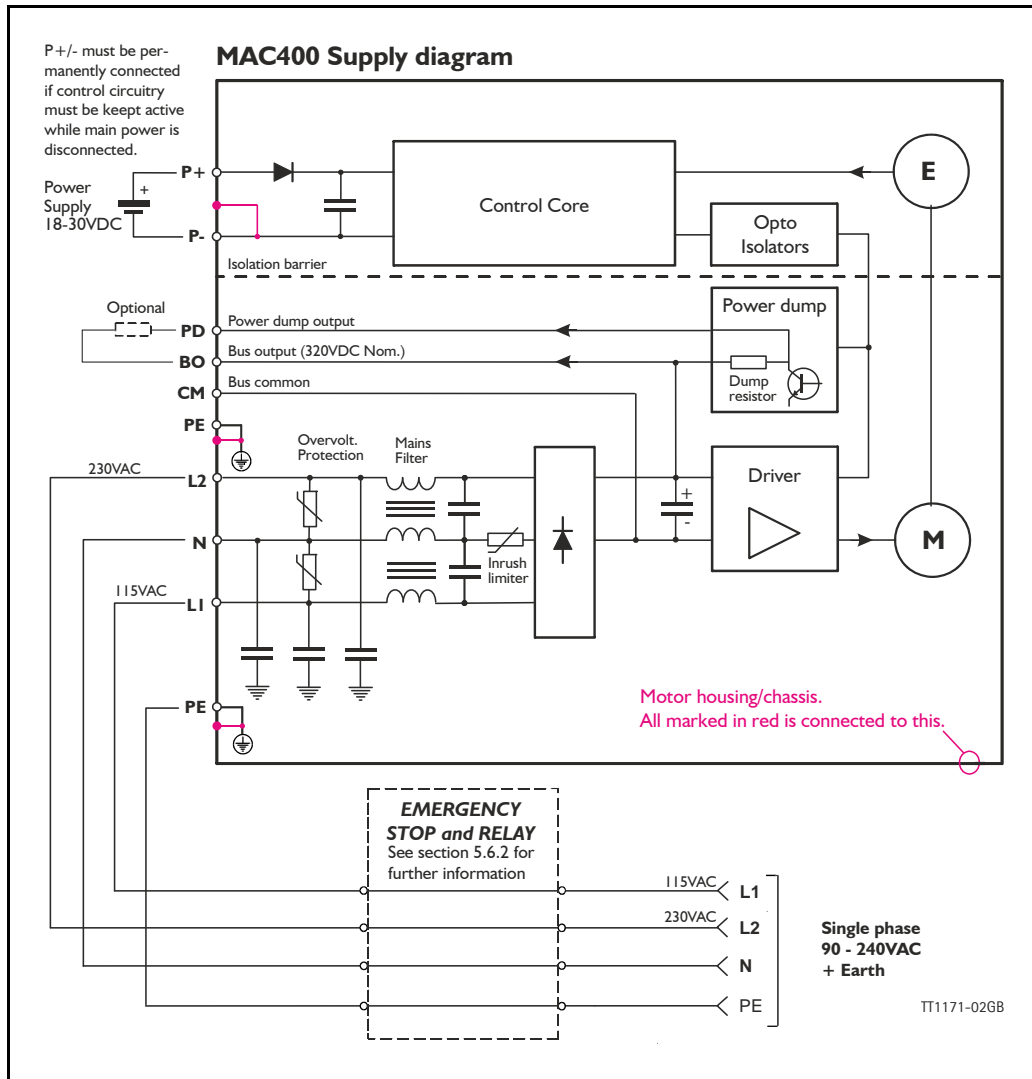

The circuit above is shown with an emergency relay (box) which can be omitted if the application does not require this safety feature. There are shown examples of Emergency stop and relay in section 5.6.2

The internal power dump is intended to cover 90% of all applications but if the error message “overvoltage” is monitored, an external power dump resistor must be connected between the terminals PD and BO.

### 3.2.7 Emergency stop

Please consult the chapter: *Emergency stop considerations*, page 360

## 3.2

# Power Supply

Only MAC400

### 3.2.8 How to connect power supply (only MAC400)

The power supply for the control circuitry is connected through the expansion module at the terminals called P+ and P- or directly at the internal power supply connector. The power circuitry must be applied according to the illustration below.

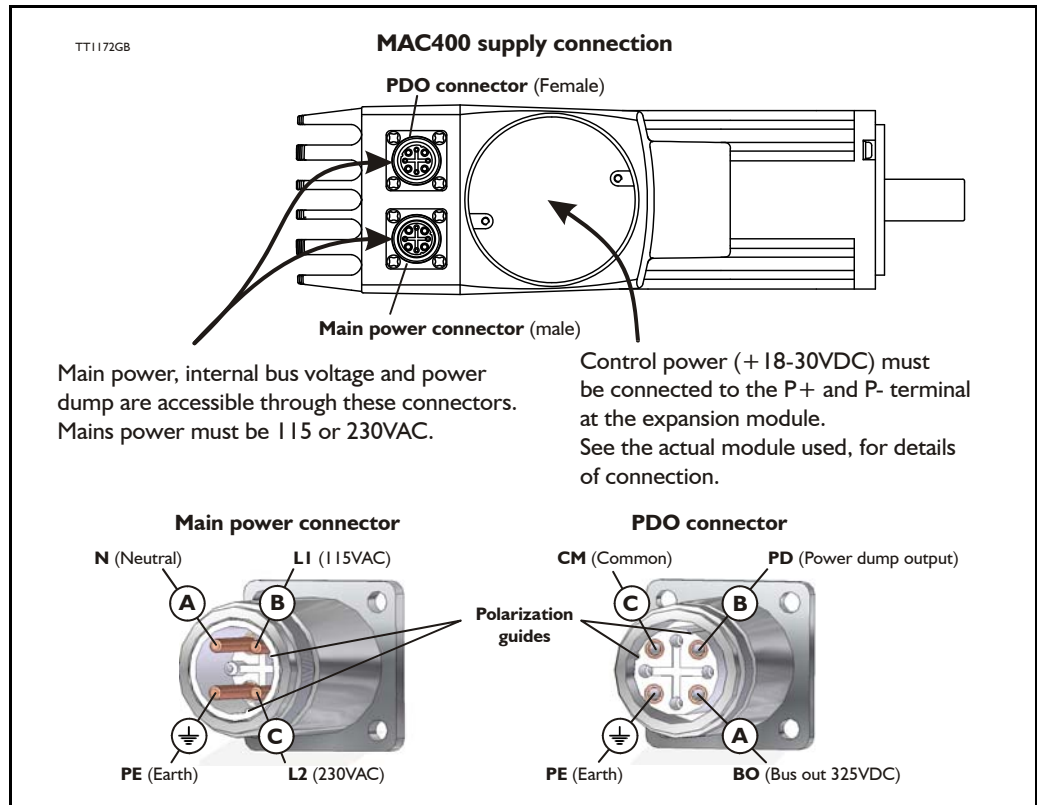

#### Terminal descriptions:

- L1 115VAC input (phase) **WARNING:** Please be aware that high voltage is present also when terminal is unconnected !.
- L2 230VAC input (phase) **WARNING:** Please be aware that high voltage is present also when terminal is unconnected !.
- N 115/230VAC input (neutral).
- PE Earth must be used with the DC-bus and the PD terminals.
- PD Power dump out - see also *Connecting an external power dump resistor, page 102.*
- BO Bus output (nom. 325VDC).
- CM Common. Ground for the internal DC-bus.

.....  
**Note:** Please use screened cables only. The screen must be connected to the metal connector housing which is also internally connected to the earth terminal.



### 3.2.9 MAC400 Grounding

Make sure that the machine part on which the MAC400 is mounted is properly grounded to the main part (body) of the machine in order to avoid major ground/earth current to flow through the motor and cause interference to other signal groups.

## 3.2

# Power Supply

Only MAC400

### 3.2.10 Sizing the external fuse (Prefuse).

When using **115V** supply voltage:

To met UL requirements, the prefuse must be a class RK5 such as the type FRN-R-10 (10Amp.) from manufacturer: Cooper Bussmann INC.

When using **230V** supply voltage:

Prefuse T6.3A@230VAC type gG, Do or Dz in the phase line Rated for600V/150kA.

### 3.2.11 Connecting an external power dump resistor

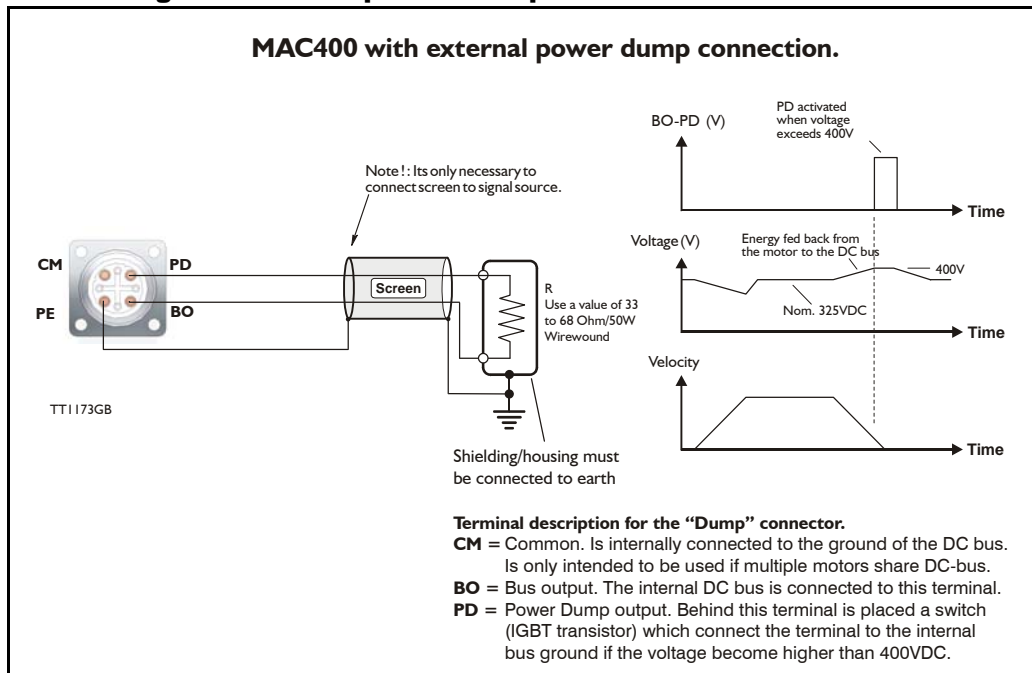

The internal power dump can absorb up to 6W continuously and 1.4kW peak, which is considered as appropriate for most applications.

However should a situation occur in which the connected load inertia is too large or the deceleration too fast, the internal power dump will not be able to absorb all the returned energy and will report the error message "regenerative overload".

In this situation the only possible solutions are as follows:

1. Decrease the acceleration/deceleration parameter.
2. Lower the attached load inertia.
3. Connect an external power resistor.

The drawing above shows how to connect an external power resistor. A wirewound type is recommended since it will be able to absorb higher peak power than other types of resistors.

**Warnings:** Ensure that the resistor value is between 33 to 68 Ohm/50W since the output otherwise can be damaged. Also avoid short-circuit of the output.



**CAUTION** - Risk of electric shock. Disconnect all power and wait 5 min. before servicing

## 3.2

# Power Supply

Only MAC400

### 3.2.12 Power cable accessories for MAC400

The following standard cables can be supplied by JVL

JVL no.	Type	Description
WP0002	MAC400	115/230VAC power cable 2 m. Straight M16 conn and free end. Female
WP0005	MAC400	115/230VAC power cable 5 m. Straight M16 conn and free end. Female
WP0020	MAC400	115/230VAC power cable 20 m. Straight M16 conn and free end. Female
WP0102	MAC400	Brake resistor cable 2 m. Straight M16 conn and free end. Male
WP0105	MAC400	Brake resistor cable 5 m. Straight M16 conn and free end. Male
WP0120	MAC400	Brake resistor cable 20 m. Straight M16 conn and free end. Male
WP0402	MAC400	230V power cable with earth 2m. Straight M16 conn and free end. Female
WP0405	MAC400	230V power cable with earth 5m. Straight M16 conn and free end. Female
WP0420	MAC400	230V power cable with earth 20m. Straight M16 conn and free end. Female

Please use the illustration below when connecting the cables.

**Warning:** Please notice that it can be fatal connecting 230V to the 115V input.

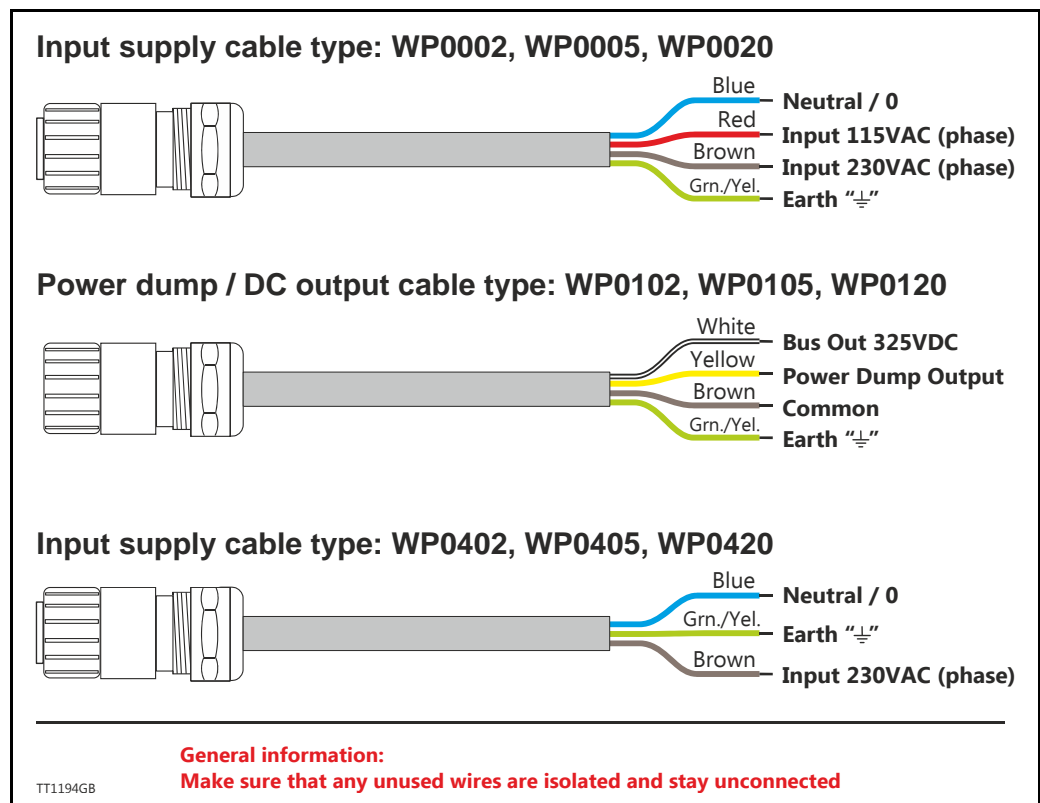

## 3.2

# Power Supply

Only MAC400

### 3.2.13 Power connector parts for MAC400

Manufacturer : Hummel AG - Germany.

General web: <http://www.hummel-group.com>

US web: <http://www.sealconusa.com>

Used for	Part description	Hummel part no.	JVL part no.
Power 115/230VAC	Connector kit with all necessary connector parts. Contains: 1pcs. WG0227 4pcs. WG0229, 1pcs. WG0230		MAC400-CONKIT1-PWR
Brake resistor/DC bus	Connector kit with all necessary connector parts. Contains: 1pcs. WG0226 4pcs. WG0228, 1pcs. WG0230		MAC400-CONKIT1-DCPD
Individual connector components:			
Power 115/230VAC	M16 Female conn insert nylon Accepts 3 + PE crimp sockets <b>Use 1 pcs. per connector.</b>	7003.9431.02	WG0227
Power 115/230VAC	M16 Crimp socket (female) Accepts 0.34 to 1.5mm <sup>2</sup> wires / AWG16 to AWG22. <b>Use 4 pcs. per connector.</b>	7010.9816.02	WG0229
Power 115/230VAC	M16 Straight metal housing Accepts cable with outer dia. 5.0 to 9.0mm / 0.2" to 0.53" <b>Use 1 pcs. per connector.</b>	7810.4000.00	WG0230
Power 115/230VAC	Optional - same as above but 90 degree housing.	7830.4000.00	WG0231
Brake resistor/DC bus	M16 Male conn insert nylon. Accepts 3 + PE crimp pins. <b>Use 1 pcs. per connector.</b>	7003.9431.01	WG0226
Brake resistor/DC bus	M16 Crimp pin (male) Accepts 0.34 to 1.5mm <sup>2</sup> wires / AWG16 to AWG22. <b>Use 4 pcs. per connector.</b>	7010.9816.01	WG0228
Brake resistor/DC bus	M16 Straight metal housing Accepts cable with outer dia. 5.0 to 9.0mm / 0.2" to 0.53" <b>Use 1 pcs. per connector.</b>	7810.4000.00	WG0230
Brake resistor/DC bus	Optional - same as above but 90 degree housing.	7830.4000.00	WG0231
Brake resistor/DC bus	Metal protection cap. Mounted if connector is not in use	7010.9001.62	WG0224
-	Crimp tool	7.000.900.904	Not for sale

## 3.2

# Power Supply

Only MAC402

### 3.2.14 Power supply circuitry (only MAC402)

The MAC402 supply is split into 2 individual circuits with no galvanic isolation in between the circuits. The control circuitry requires a voltage (P+ and P- terminals) in the range 18 to 30VDC and the main power circuitry (M+ and M- terminals) must be supplied with +12 to 48VDC nominal. Having 2 independent supply circuits offers the feature that the supply voltage for the power circuitry (+12-48VDC) can be removed for safety reasons, while the control circuitry can continue operating and thus keep the position counter updated and keep other vital functions such as communication active.

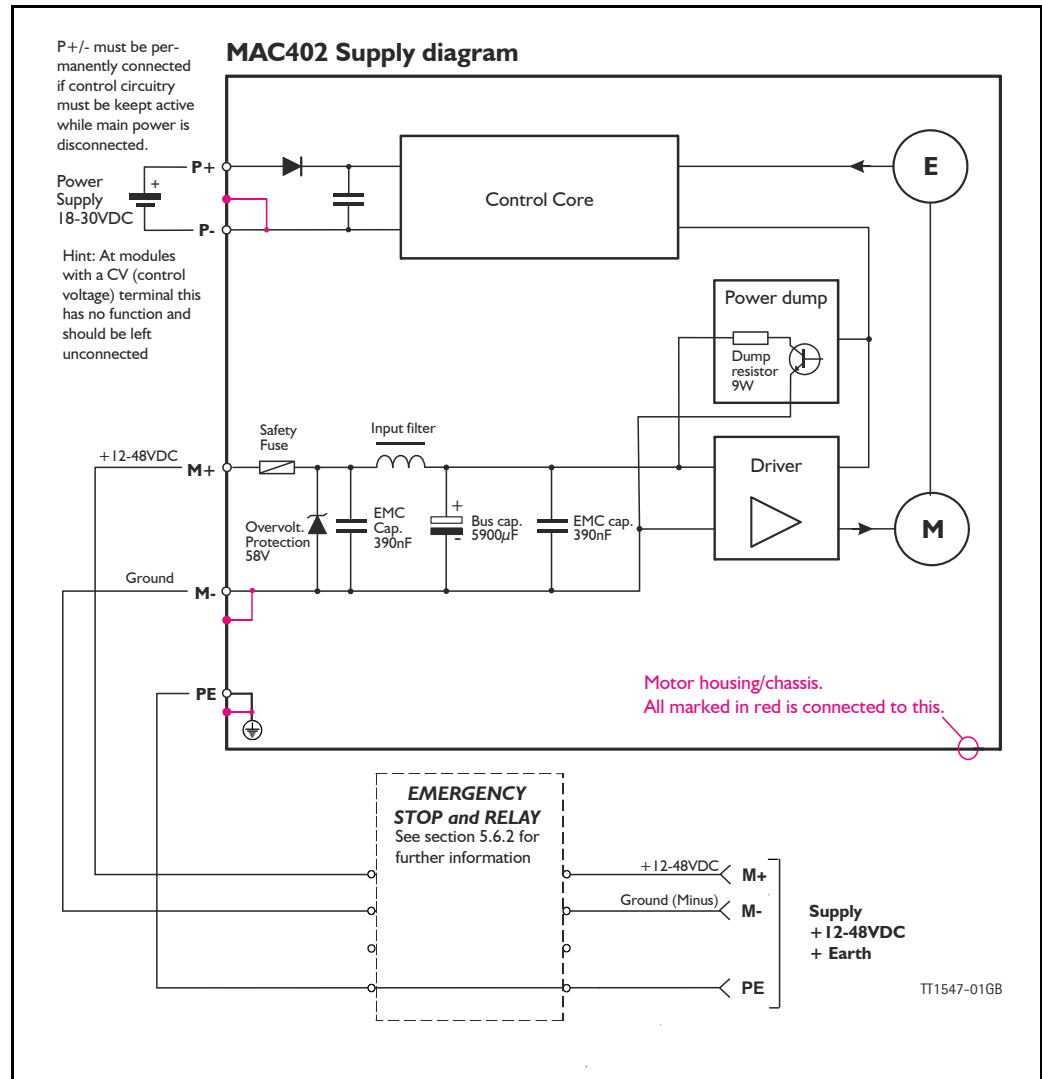

The circuit above is shown with an emergency relay (box) which can be omitted if the application does not require this safety feature. There are shown examples of Emergency stop and relay in section 5.6.2

The internal power dump is intended to cover 90% of all applications but if the error message "overvoltage" is monitored, an external power dump unit must be connected such as the JVL type PSU00-PDI. See also [Power Supplies, page 416](#).

### 3.2.15 Emergency stop

Please consult the chapter: *Emergency stop considerations, page 360*

### 3.2.16 How to connect power supply (only MAC402)

The power supply for the control circuitry is connected through the expansion module at the terminals called P+ and P- or directly at the internal power supply connector. The power circuitry must be applied according to the illustration below.

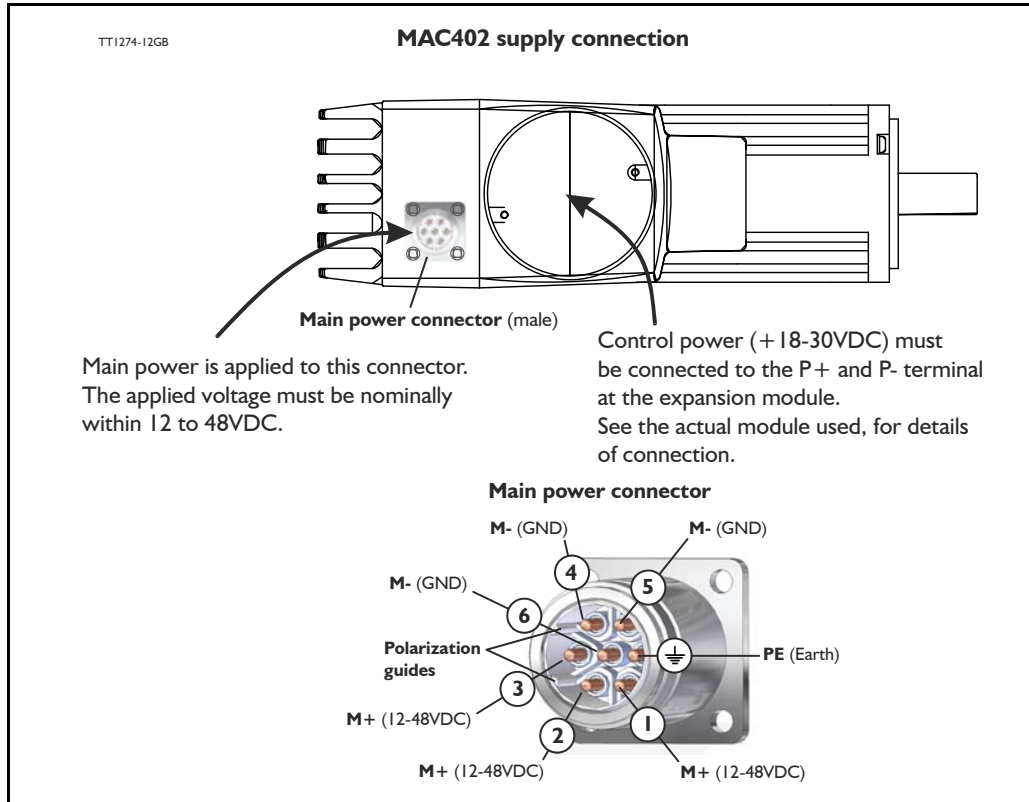

#### Terminal descriptions:

**M+** 12-48VDC nominal  
(Pin 1, 2 and 3)

**WARNING:** Please use connections from all 3 indicated pins in order to spread the current over all pins in the connector. This will extend the lifetime of the contacts.

**M-** GND  
(Pin 4, 5 and 6)

**WARNING:** Please use connections from all 3 indicated pins in order to spread the current over all pins in the connector. This will extend the lifetime of the contacts.

**PE** Earth  
(Pin PE)

Connect to machine ground to assure that the potential of the motor is earthed. Notice that PE internally in the motor is connected directly to the motor housing/body.

.....

**Note:** Please use screened cables only. The screen must be connected to the metal connector housing which is also internally connected to the earth terminal.

### 3.2.17 MAC402 Grounding

Make sure that the machine part on which the MAC402 is mounted is properly grounded to the main part (body) of the machine in order to avoid major ground/earth current to flow through the motor and cause interference to other signal groups such as interface cables.



## 3.2

# Power Supply

Only MAC402

### 3.2.18 Power cable accessories for MAC402

The following standard cables can be supplied by JVL

JVL no.	Type	Description
WP0502	MAC402	12-48VDC power cable 2 m. Straight M16 conn and flying end. Female
WP0505	MAC402	12-48VDC power cable 5 m. Straight M16 conn and flying end. Female
WP0520	MAC402	12-48VDC power cable 20 m. Straight M16 conn and flying end. Female

Please use the illustration below when connecting the cables.

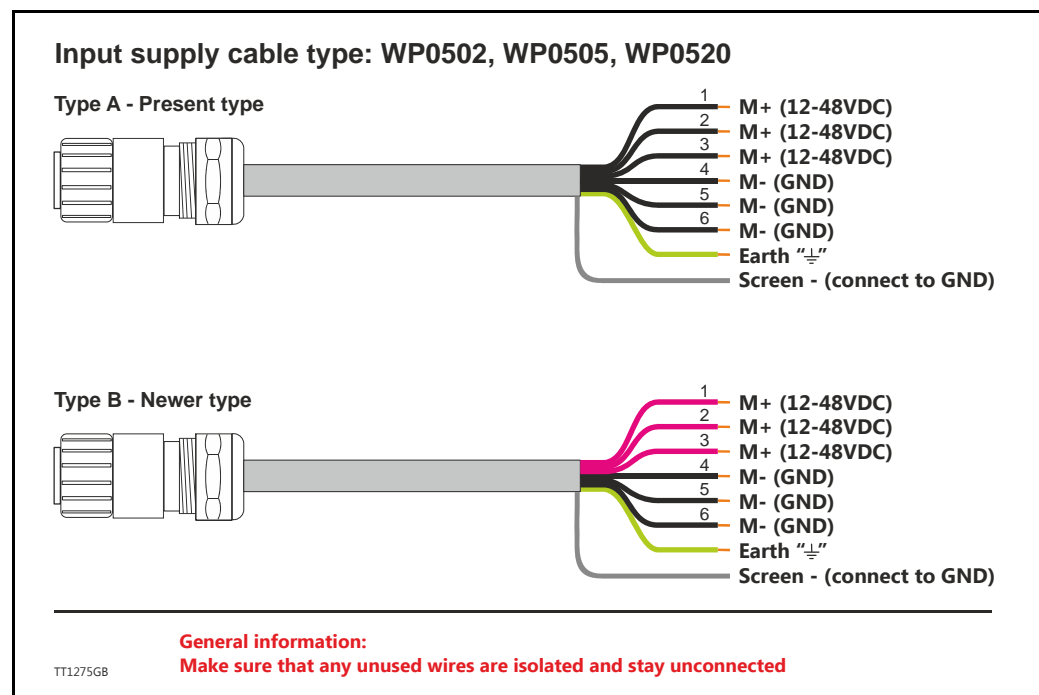

## 3.2

# Power Supply

Only MAC402

### 3.2.19 Power connector parts for MAC402

Manufacturer : Hummel AG - Germany.

General web: <http://www.hummel-group.com>

US web: <http://www.sealconusa.com>

Used for	Part description	Hummel part no.	JVL part no.
Power 12-48VDC	Connector kit with all necessary connector parts. Contains: 1pcs. WG0253 7pcs. WG0254, 1pcs. WG0230		MAC402-CONKIT1-PWR
Individual connector components:			
Power 12-48VDC	M16 Female conn insert nylon Accepts 6+ PE crimp sockets <b>Use 1 pcs. per connector.</b>	7.003.961.102	WG0253
Power 12-48VDC	M16 Crimp socket (female) Accepts 0.34 to 1.5mm <sup>2</sup> wires / AWG16 to AWG22. <b>Use 7pcs. per connector.</b>	7.010.981.212	WG0254
Power 12-48VDC	M16 Straigth metal housing Accepts cable with outer dia. 5.0 to 9.0mm / 0.2" to 0.53" <b>Use 1 pcs. per connector.</b>	7810.4000.00	WG0230
Power 12-48VDC	Optional - same as above but 90 degree housing.	7830.4000.00	WG0231
-	Crimp tool	7000.9009.04	Not for sale

## 3.2

# Power Supply

Only MAC800

### 3.2.20 Power supply circuitry (only MAC800)

The MAC800 supply is split into 2 individual circuits with full galvanic isolation between the circuits. The control circuitry requires a voltage in the range 18 to 30VDC and the power circuitry must be supplied with 90 to 240VAC (Set by solder jumper *Using 115V supply voltage (only MAC800), page 101*). Having 2 independent supply circuits offers the feature that the supply voltage for the power circuitry (90-240VAC) can be removed for safety reasons, while the control circuitry can continue operating and thus keep the position counter updated and keep other vital functions such as communication active.

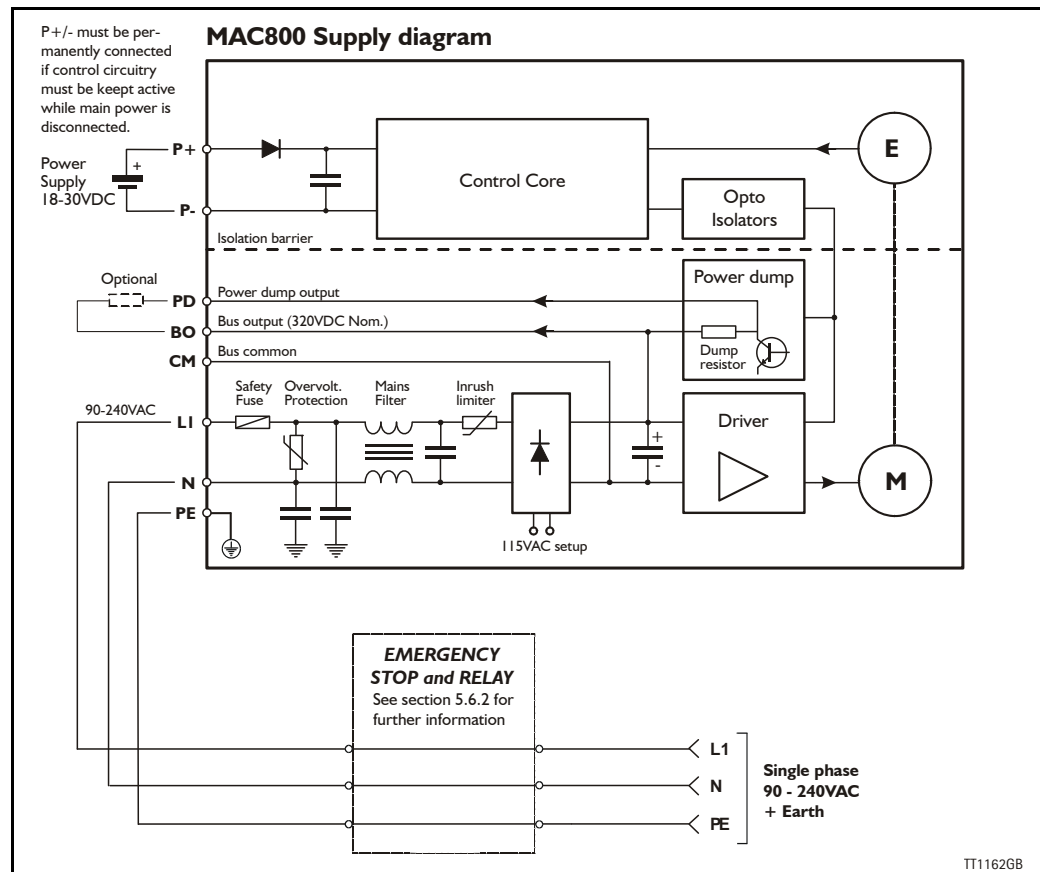

The circuit above is shown with an emergency relay (box) which can be omitted if the application does not require this safety feature. There are shown examples of Emergency stop and relay in section 5.6.2. The internal power dump is intended to cover 90% of all applications but if the error message "overvoltage" is monitored, an external power dump resistor must be connected between the terminals PD and BO.

### 3.2.21 Emergency stop

Please consult the chapter: *Emergency stop considerations, page 360*.

### 3.2.22 Sizing the external fuse (Prefuse).

When using **115V** supply voltage:

To met UL requirements, the prefuse must be a class RK5 such as the type FRN-R-15 (15Amp.) from manufacturer: Cooper Bussmann INC.

When using **230V** supply voltage:

Prefuse T10A@230VAC type gG, Do or Dz in the phase line Rated for 600V/150kA.

**3.2.23 How to connect the power supply (only MAC800)**

The power supply for the control circuitry is connected through the expansion module at the terminals called P+ and P- or directly at the internal power supply connector. The power circuitry must be applied according to the illustration below.

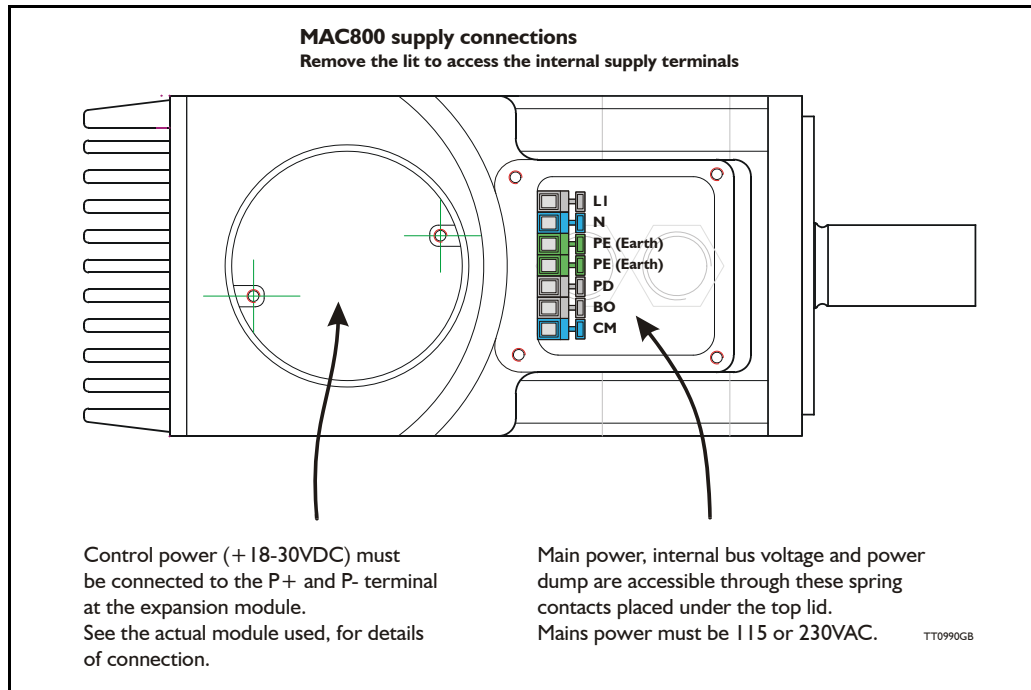
**Terminal descriptions:**

- LI 115/230VAC input (phase). (The voltage range is set by solder jumper)
- N 115/230VAC input (neutral). (The voltage range is set by solder jumper)  
See *Using 115V supply voltage (only MAC800)*, page 101.
- PE Earth must be used with the DC-bus and the PD terminals.
- PD Power dump output - see also *Connecting an external power dump resistor*, page 102.
- BO Bus output (nom. 325VDC).
- CM Common. Ground for the internal DC-bus.

**Important notes:**

- If 115VAC is used as supply voltage the MAC800 must be set up for this. See *Using 115V supply voltage (only MAC800)*, page 101.
- Screened cables is recommended.

**3.2.24 MAC800 Grounding**

Make sure that the machine part on which the MAC800 is mounted is properly grounded to the main part (body) of the machine in order to avoid major ground/earth current to flow through the motor and cause interference to other signal groups such as interface cables.

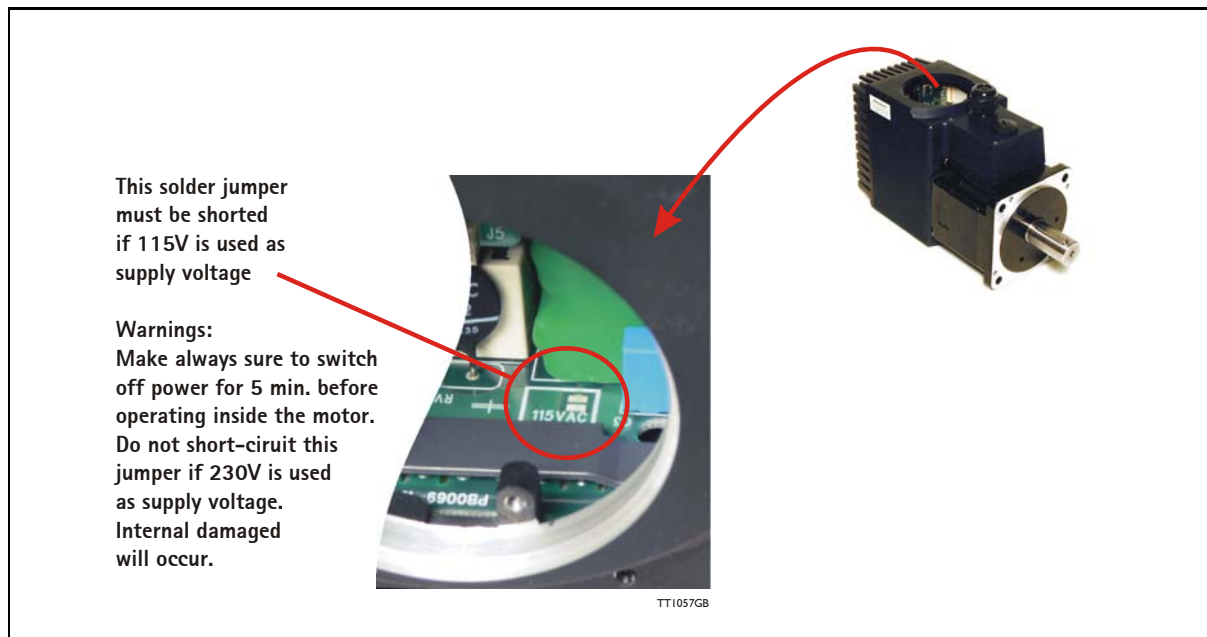

### 3.2.25 Using 115V supply voltage (only MAC800)

Supplying the MAC800 with 115 VAC, it can run with the same performance as when supplied with 230 VAC – provided you solder the jumper as shown in the drawing. Then the internal bus voltage will remain at the nominal value of 325 VDC even though 115 VAC is applied.

It is possible to supply the MAC800 with 115 VAC without using the jumper, but then the MAC800 will only be able to operate within a limited speed range and the motor efficiency and dynamic response will also not be optimal.

Therefore it is recommended to use 115 VAC with the jumper is soldered correctly.

To check that the jumper is set properly, the bus voltage displayed in the MacTalk main screen must show approximately 325 VDC. If the jumper is not set correctly, the voltage shown will only be half of this value (160-170 VDC).

#### Important !:

Make sure that the jumper is not short-circuited if 230VAC is applied since this will cause fatal damage to internal components.

The MAC800 motor is configured by default for 230VAC supply (jumper not short-circuited) on delivery.



### 3.2.26 Prefuse when using 115V supply (only MAC800)

To fulfil UL requirements, the prefuse must be a class RK5 such as the type FRN-R-15 (15Amp.) from manufacturer: Cooper Bussmann INC.

See also *Power supply circuitry (only MAC800)*, page 99

## 3.2

# Power Supply

Only MAC800

### 3.2.27 Connecting an external power dump resistor

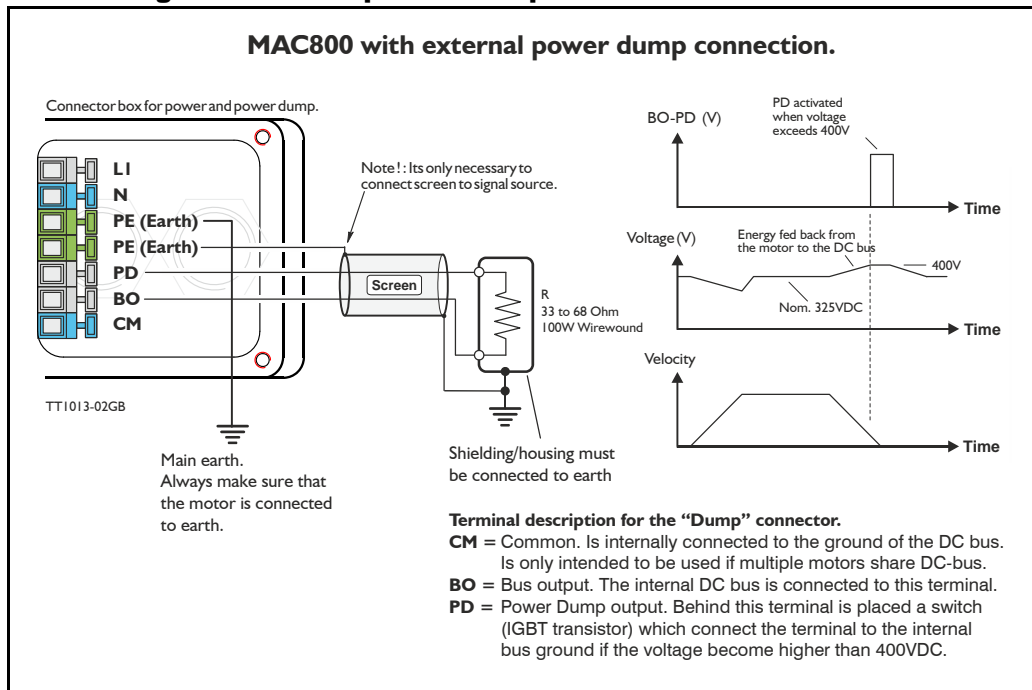

The internal power dump can absorb up to 9W continuously and 2.5kW peak, which is considered as appropriate for most applications.

However should a situation occur in which the connected load inertia is too large or the deceleration too fast, the internal power dump will not be able to absorb all the returned energy and will report the error message "regenerative overload".

In this situation the only possible solutions are as follows:

1. Decrease the acceleration/deceleration parameter.
2. Lower the attached load inertia.
3. Connect an external power resistor.

The drawing above shows how to connect an external power resistor. A wirewound type is recommended since it will be able to absorb higher peak power than other types of resistors. A wirewound resistor with the value 33 Ohm or 47 Ohm is the optimum.

**Warnings:** Ensure that the resistor value is not lower than 33 Ohm since the output can be damaged. Also avoid short-circuit of the output.



**CAUTION** - Risk of electric shock. Disconnect all power and wait 5 min. before servicing

## 3.2

# Power Supply

Only MAC1500/3000

### 3.2.28 Power supply circuitry (only MAC1500 & 3000)

The MAC1500 & MAC3000 supply is split into 2 individual circuits with full galvanic isolation between the circuits. The control circuitry requires a voltage in the range 18 to 30VDC and the power circuitry must be supplied with 3phase 400 to 480VAC. Having 2 independent supply circuits offers the feature that the supply voltage for the power circuitry (400-480VAC) can be removed for safety reasons, while the control circuitry can continue operating and thus keep the position counter updated and keep other vital functions such as communication active.

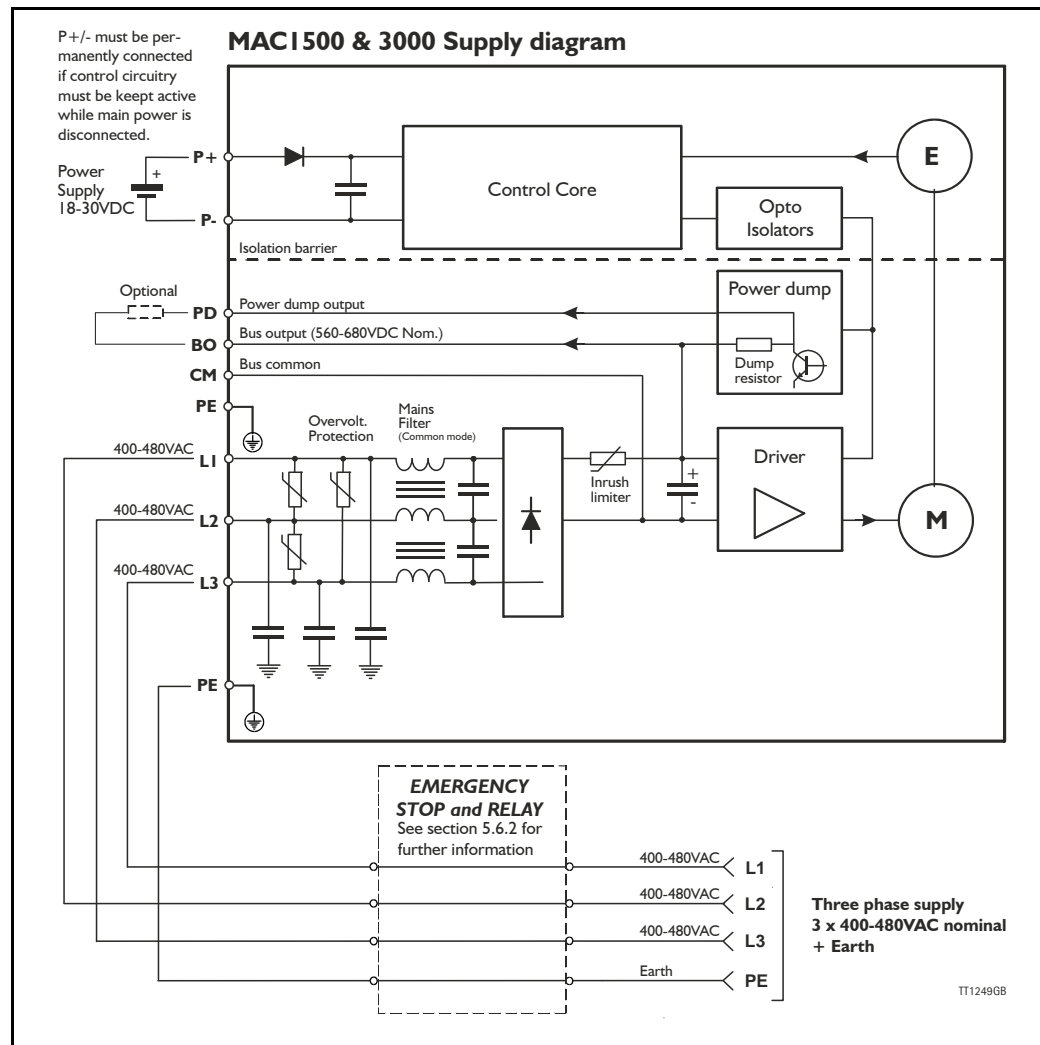

The circuit above is shown with an emergency relay (box) which can be omitted if the application does not require this safety feature. There are shown examples of Emergency stop and relay in section 5.6.2

The internal power dump is intended to cover 90% of all applications but if the error message "overvoltage" is monitored, an external power dump resistor must be connected between the terminals PD and BO.

## 3.2

## Power Supply

Only MAC1500/3000

### 3.2.29 Current consumption

The supply current measured in each of the 3 supply phases is as follows:

<b>MAC1500 at nominal shaft load (at 3000RPM)</b>		
@400VAC	@460VAC	@480VAC
2.53 ARMS	2.17 ARMS	2.08 ARMS
<b>MAC1500 at peak shaft load (at 3000RPM)</b>		
@400VAC	@460VAC	@480VAC
7.59 ARMS	6.50 ARMS	6.24 ARMS

<b>MAC3000 at nominal shaft load (at 3000RPM)</b>		
@400VAC	@460VAC	@480VAC
5.06 ARMS	4.34 ARMS	4.16 ARMS
<b>MAC3000 at peak shaft load (at 3000RPM)</b>		
@400VAC	@460VAC	@480VAC
15.18 ARMS	13.00 ARMS	12.48 ARMS

Please notice that the current values shown above is nominal values. Higher values may appear depending on the quality of the supply.

### 3.2.30 Emergency stop

Please consult the chapter: *Emergency stop considerations, page 360*



## 3.2

# Power Supply

Only MAC1500 & 3000

### 3.2.31 How to connect power supply (only MAC1500 & MAC3000)

The low voltage (24VDC) power supply for the control circuitry is connected through the expansion module at the terminals called P+ and P- or directly at the internal power supply connector. The Main power (400-480VAC nom.) must be applied according to the illustration below.

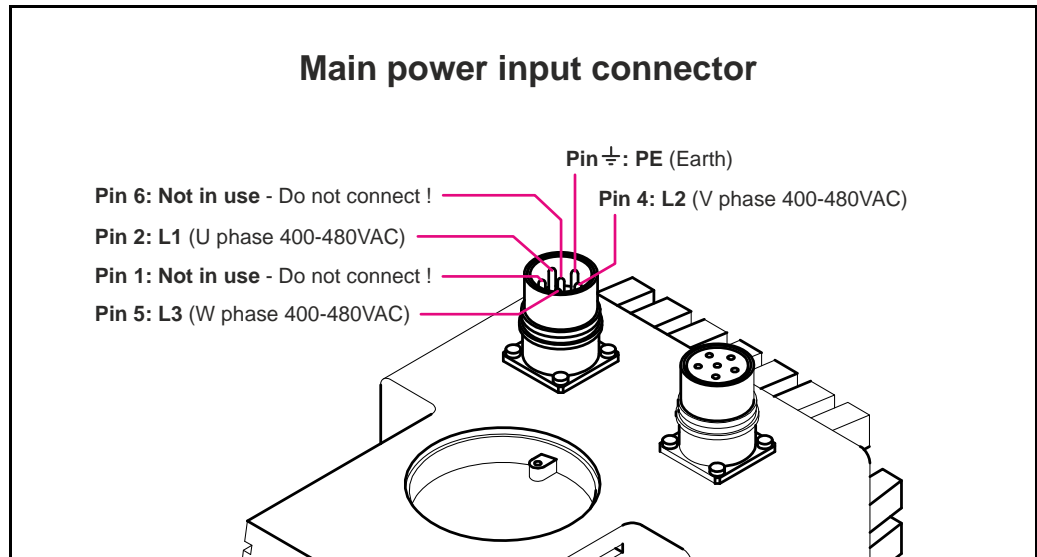

#### Terminal descriptions:

- L1 400-480VAC input (U phase) **WARNING:** Please be aware that high voltage can be present also when the terminal is unconnected !
- L2 400-480VAC input (V phase) **WARNING:** Please be aware that high voltage can be present also when the terminal is unconnected !
- L3 400-480VAC input (W phase) **WARNING:** Please be aware that high voltage can be present also when the terminal is unconnected !
- PE Earth - make sure to connect this terminal to a proper ground in order to avoid electrical shock.

.....  
**Note:** Please use screened cables only. The screen must be connected to the metal connector housing which is also internally connected to the earth terminal.



### 3.2.32 Sizing the external fuse (Prefuse).

To meet UL requirements, the prefuse must be a class RK5 such as the type FRN-R-8 (8Amp.) for MAC1500 and FRN-R-15 (15Amp.) for MAC3000 from manufacturer: Cooper Bussmann INC.

### 3.2.33 MAC1500 & 3000 Grounding

Make sure that the machine part on which the MAC1500 or 3000 is mounted is properly grounded to the main part (body) of the machine in order to avoid major ground/earth current to flow through the motor and cause interference to other signal groups such as interface cables.

## 3.2

## Power Supply

Only MAC1500 & 3000

### 3.2.34 Power dump connector

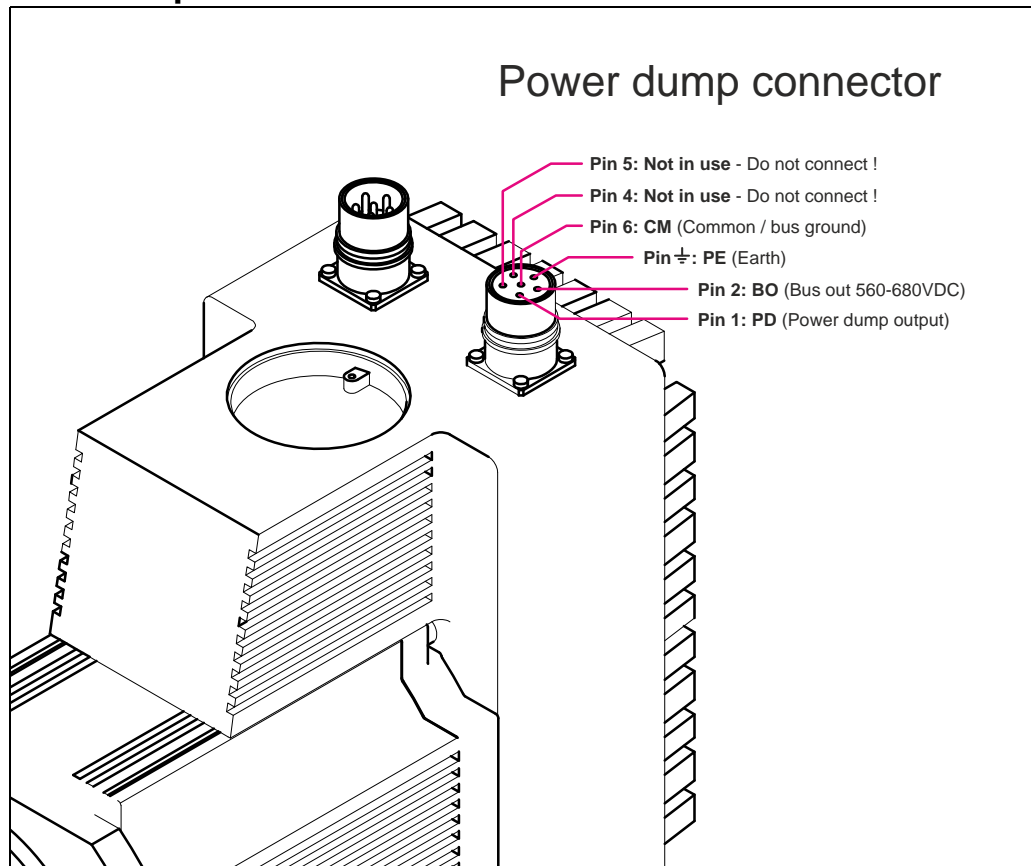

## 3.2

# Power Supply

Only MAC1500 & 3000

### 3.2.35 Power connector parts for MAC1500 & 3000

Manufacturer : Hummel AG - Germany.

General web: <http://www.hummel-group.com>

US web: <http://www.sealconusa.com>

Used for	Part description	Hummel part no.	JVL part no.
Power 3 phase 400-480VAC	Connector kit with all necessary connector parts. Contains: 1pcs. WG0241 4pcs. WG0243, 1pcs. WG0245		MAC1530-CONKIT1-PWR
Brake resistor/ DC bus	Connector kit with all necessary connector parts. Contains: 1pcs. WG0240 4pcs. WG0242, 1pcs. WG0245		MAC1530-CONKIT1-DCPD
Individual connector components:			
Power 3 phase 400-480VAC	M23 Female conn insert nylon Accepts 3 + PE crimp sockets <b>Use 1 pcs. per connector.</b>	7.084.951.102	WG0241
Power 3 phase 400-480VAC	M23 Crimp socket (female) Accepts 0.75-2.5mm <sup>2</sup> wires / AWG14 to AWG18. <b>Use 4 pcs. per connector.</b>	7.010.942.002	WG0243
Power 3 phase 400-480VAC	M23 Straight metal housing Accepts cable with outer dia. 7.0 to 12.0mm / 0.28" to 0.47" <b>Use 1 pcs. per connector.</b>	7.550.500.000	WG0245
Brake resistor/ DC bus	M23 Male conn insert nylon. Accepts 3 + PE crimp pins. <b>Use 1 pcs. per connector.</b>	7.084.951.101	WG0240
Brake resistor/ DC bus	M23 Crimp pin (male) Accepts 0.75-2.5mm <sup>2</sup> wires / AWG14 to AWG18. <b>Use 4 pcs. per connector.</b>	7.010.942.001	WG0242
Brake resistor/ DC bus	M23 Straight metal housing Accepts cable with outer dia. 7.0 to 12.0mm / 0.28" to 0.47" <b>Use 1 pcs. per connector.</b>	7.550.500.000	WG0245
Brake resistor/ DC bus	Metal protection cap. Mounted if connector is not in use	7.010.908.102	WG0252
-	Crimp tool	7.000.900.901	Not for sale

## 3.2

# Power Supply

Only MAC1500 & 3000

### 3.2.36 Power cable accessories for MAC1500 & 3000

The following standard cables can be supplied by JVL

JVL no.	Type	Description
WP3405	MAC1500/3000	400 to 480VAC 3-phase power cable 5 m. Straight M23 conn and free end. Female

Please use the illustration below when connecting the cables.

#### Input supply cable type: WP3405

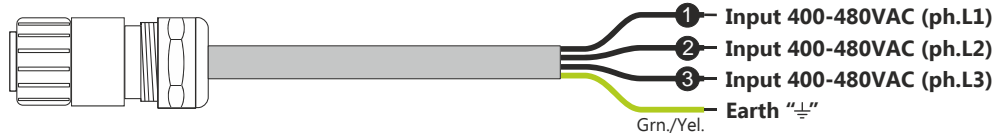

TT1250GB

**General information:**

**Make sure that any unused wires are isolated and stay unconnected**

## 3.3

# Serial interface

### 3.3.1 Interface Connection

The Controller Interface is based on an asynchronous serial interface.

3 interface signals, Rx, Tx and ground are used. The interface can be used directly with the serial COM port of any standard PC or PLC by using the optional cable type RS232-9-I-MAC which has an integrated RS232 converter. Another possibility is to use one of the expansion modules for the MAC motor which also include an RS232 and RS485 converter. See also *Accessories*, page 415.

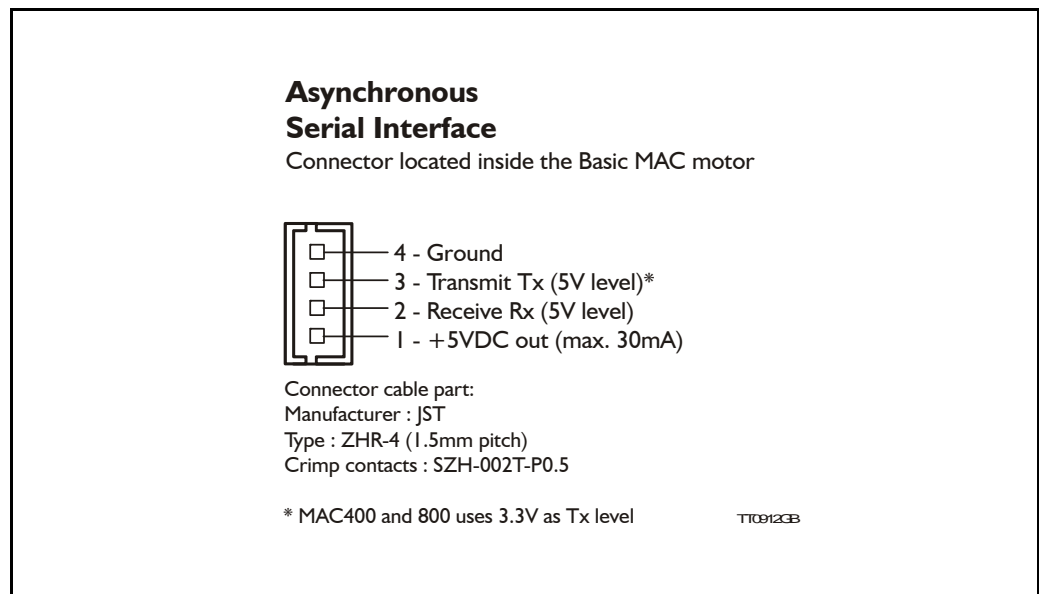

### 3.3.2 RS232 Interface signal levels

**Please note** that the signal levels are 0 to +5V(3.3V)DC and are thus not according to the RS232 standard which requires +/-12V nominal at the RX and TX signals. However the protocol used is equivalent to the RS232 protocol.

If the Basic MAC motor is implemented in an OEM application where an internal processor communicates with the MAC motor, the TX and RX terminals can normally interface directly.

## 3.4

## User I/O

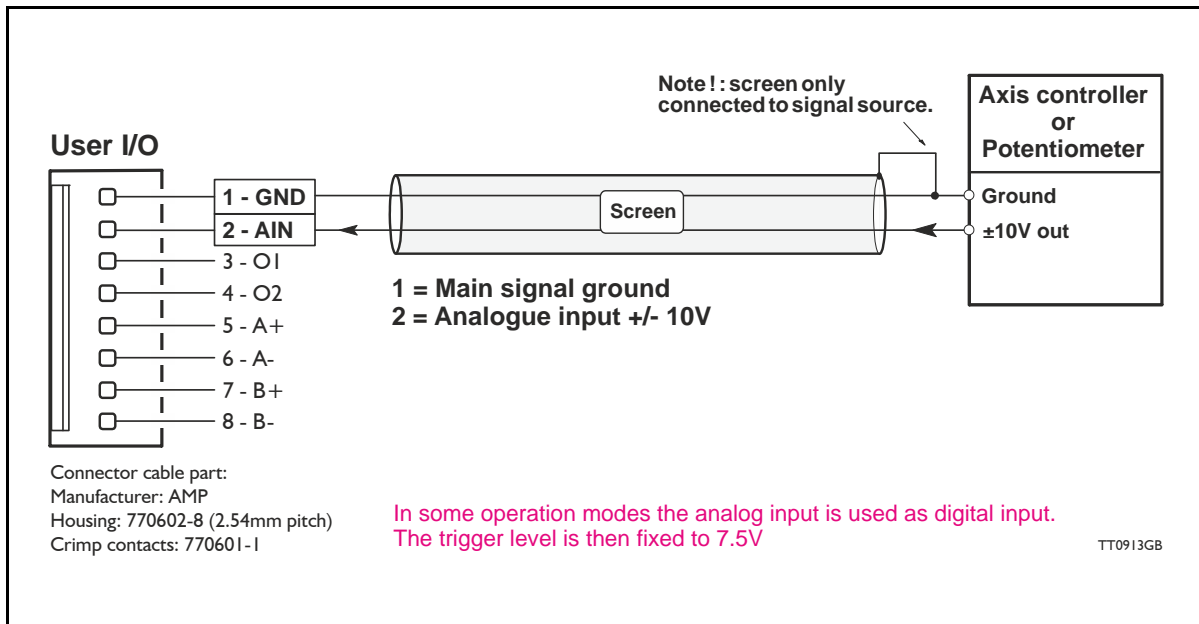

### 3.4.1 Analogue input

The analogue input can be used for two purposes in the basic MAC motor.

1. As an analogue control input when the MAC motor is used for either velocity control or torque control.
2. As a Zero Sensor input when the MAC motor is used in position or gear mode.  
For further information see *Mechanical Zero search*, page 32

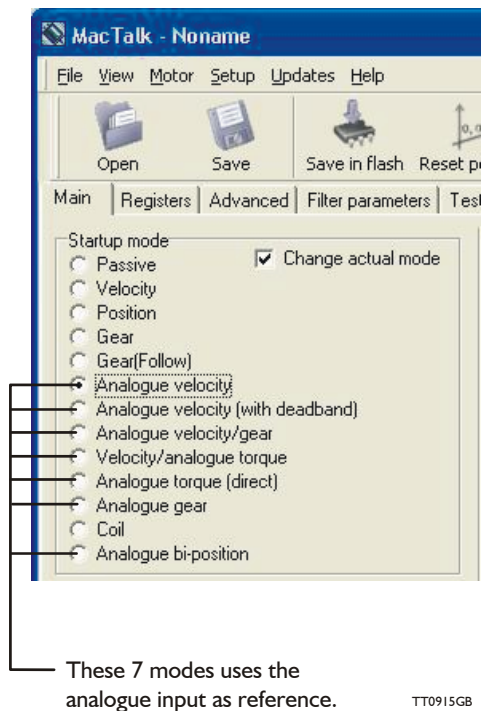

The input is automatically used as an analogue  $\pm 10V$  input when the Start-up mode in the MacTalk main window is set to one of the 7 modes such as Analogue Torque, Velocity or Velocity/Gear as shown in the accompanying illustration.

## 3.4

# User I/O

### 3.4.2 Analogue input used as digital input

The analogue input is used as digital input in some modes.

This can for example be in zero search mode where the input can be connected to an external sensor that detects when the motor have reached the mechanical zero point.

The default trigger level is 7.5V meaning that a voltage above 7.5V is seen as logic high (active) and a voltage below 7.5V is seen as logic low (passive).

#### Changing the input trigger level

The trigger level can be changed by inserting an offset voltage in the offset field/register.

#### Example:

If 5V is desired as trigger level an offset voltage of  $7.5V - 5V = +2.5$  must be inserted in the offset register.

Below is shown how this is done in MacTalk.

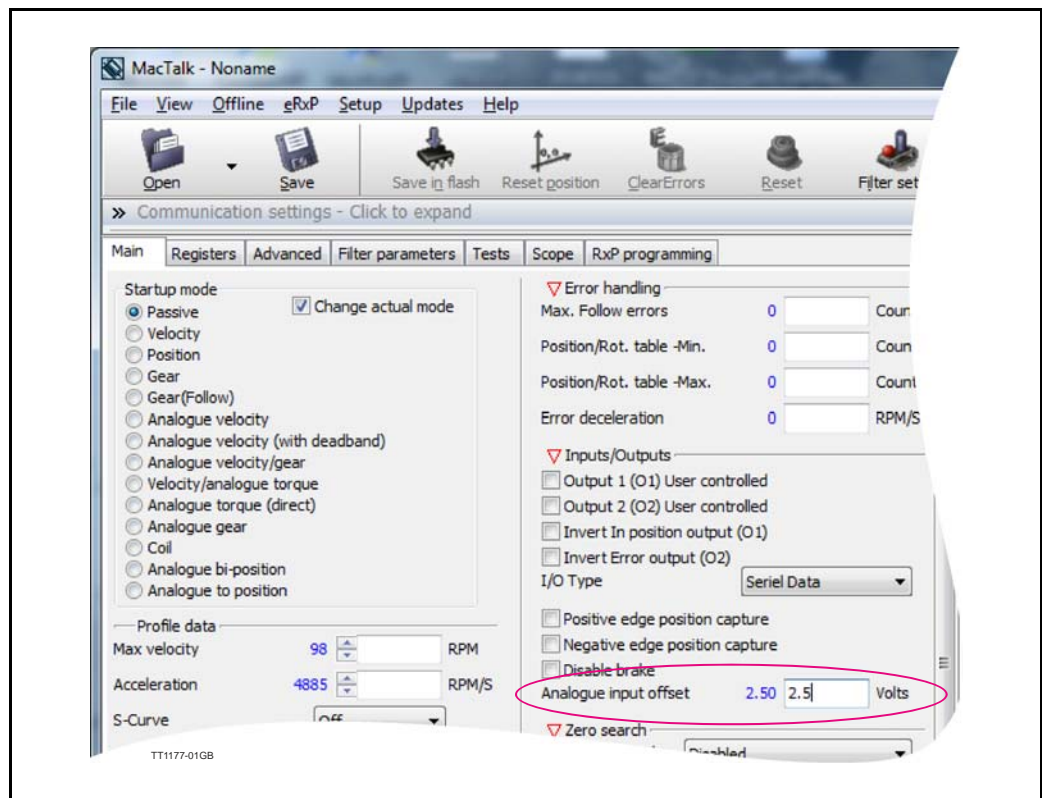

## 3.4

## User I/O

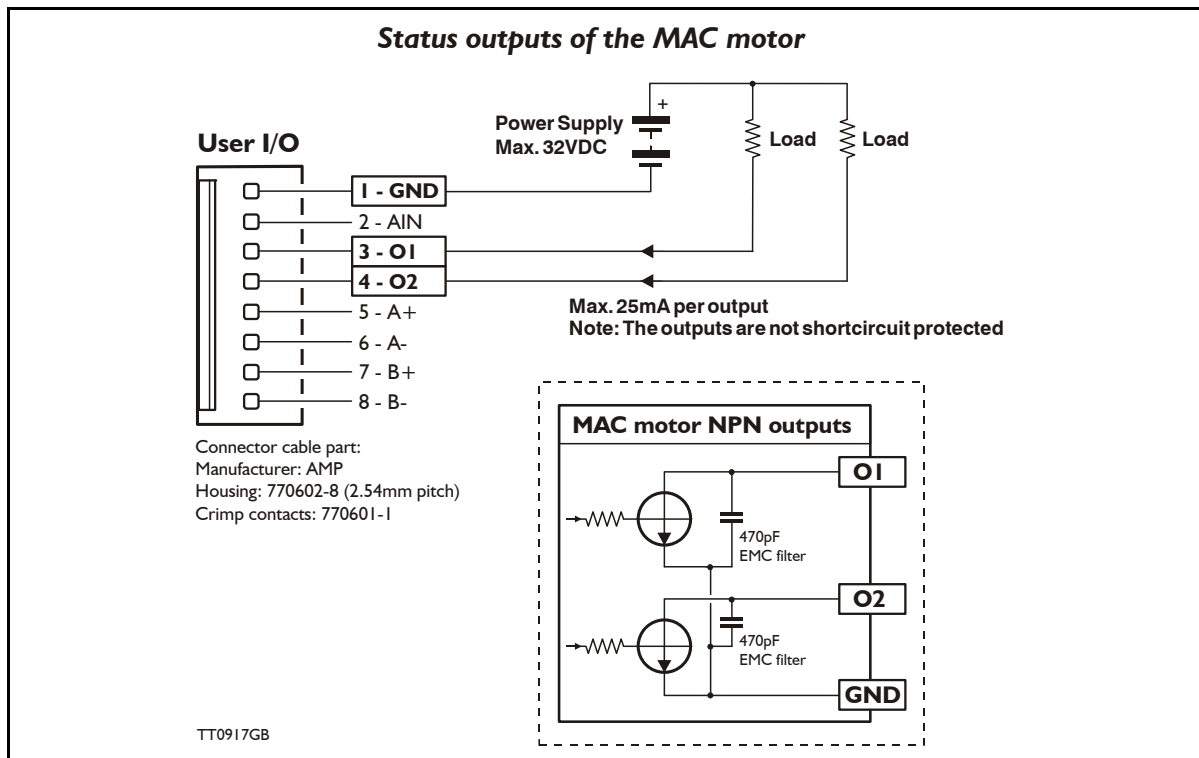

### 3.4.3 Status Outputs

The status outputs O1 and O2 indicate the actual status of the MAC motor. Each output is an NPN (!) type, which means that the load must be placed between the output and a positive supply. Note that several of the expansion modules for the MAC motor offer PNP output (source output). For further details about a specific expansion module, please see other sections of this manual.

- O1** This output functions as an “In Position” or “at velocity” output depending on which mode is selected. The position interval can be setup using the MacTalk program.
  - O2** This output is normally passive but if an unrecoverable error occurs, it will be activated to indicate that normal operation of the motor has been interrupted and no further operation is possible until a reset or power down has been made. An unrecoverable error can be one of the following conditions:
- (!) : Please note that when mounting an expansion module in the motor the output type and performance may change. Please check the description of the actual module to make sure how the outputs are configured.



## 3.4

## User I/O

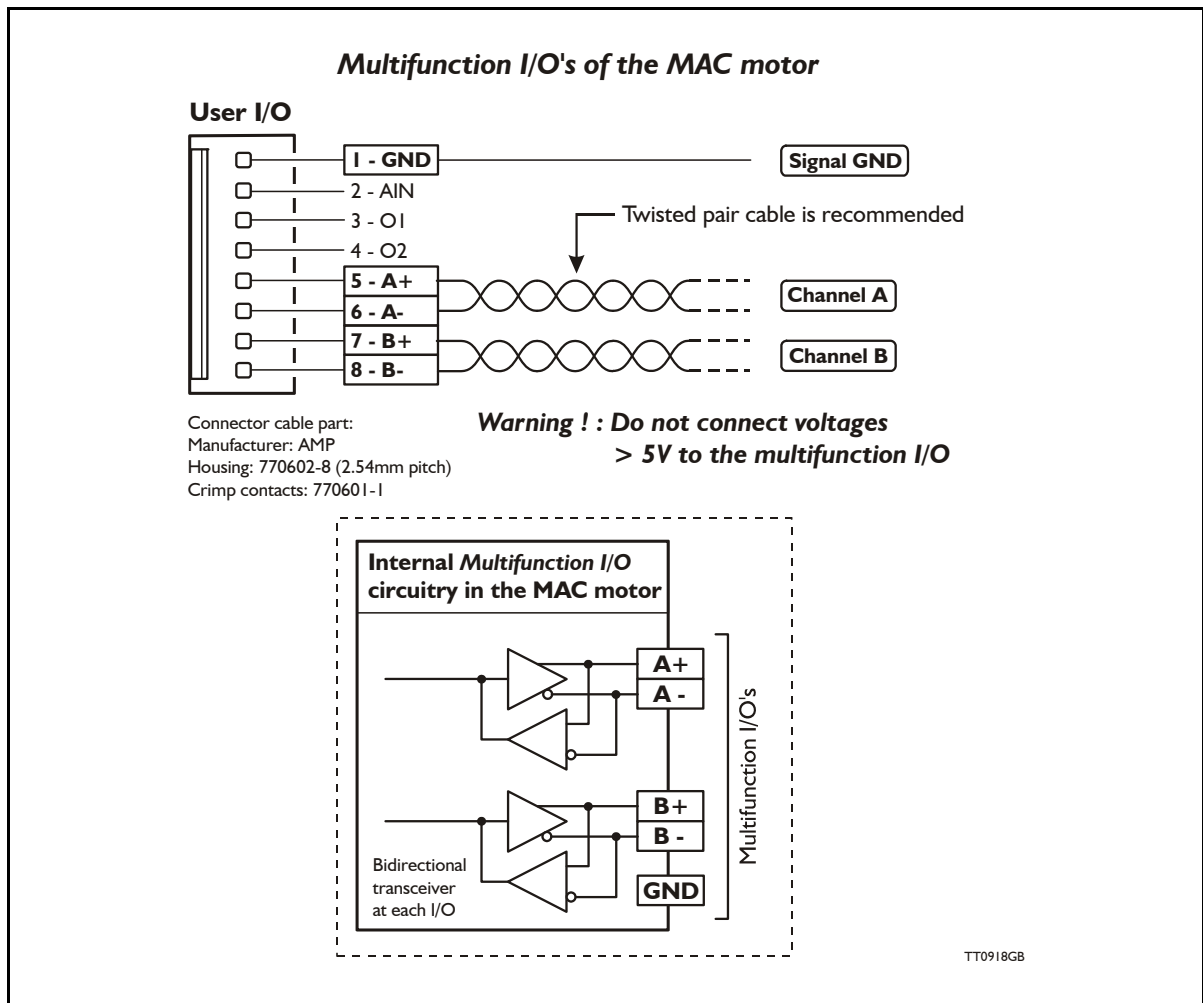

### 3.4.4 Multifunction I/O general description

The Multifunction I/O can be set up for different purposes depending on the actual mode of operation of the MAC motor.

- Pulse inputs  
When the motor is set to Gear mode, it will follow pulses at the A and B inputs. 2 input formats can be selected: pulse and direction or quadrature.
- Encoder output  
The internal encoder-pulses are output as a quadrature signal.
- RS422 communication  
A master controller can send commands, for example velocity or position commands. This interface is intended for permanent connection.

## 3.4

# User I/O

### 3.4.5 Multifunction I/O used as pulse inputs

The Multifunction I/O can be set up as pulse inputs, which is necessary to run the MAC motor in *Gear mode* or *Analogue velocity/gear mode*.

When the motor is set to Gear mode, it will follow pulses at the A and B inputs.

2 input formats can be selected.

Pulse and direction. The A input must be applied with the pulses and the B input must be applied with the direction signal.

Quadrature. Also called encoder format. The pulses at the A and B channel are 90 degree phase-shifted to determine direction.

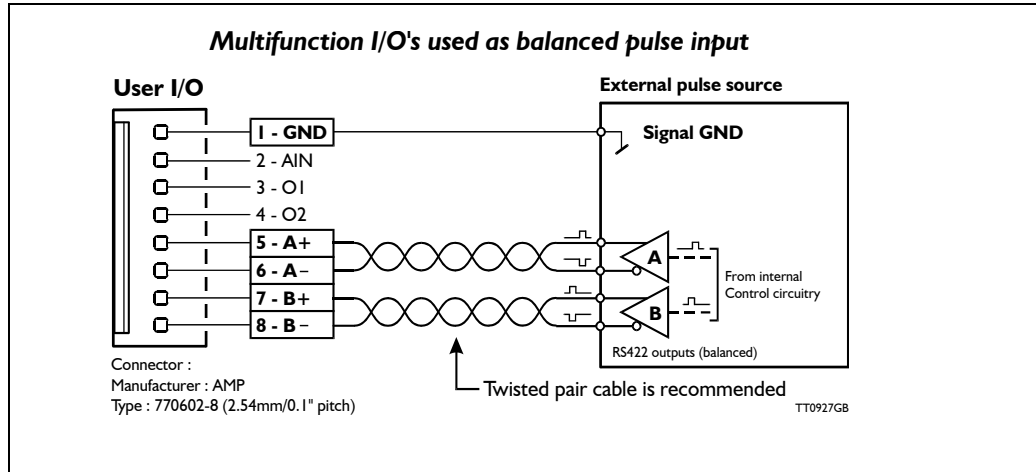

The Multifunction I/O's must be set up in MAC-Talk to function as inputs. Also, an input filter and the preferred direction of movement can be selected.

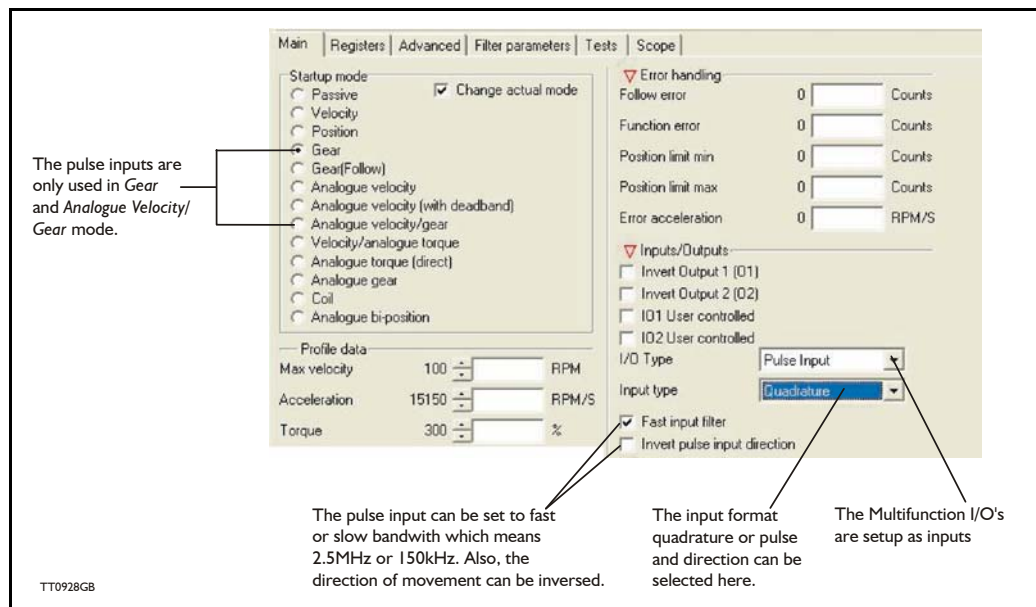

See also the descriptions of *Gear* and *Analogue Velocity/Gear* modes for further details about functionality.

## 3.4

# User I/O

### 3.4.6 Multifunction I/O used as pulse outputs

The Multifunction I/O can be set up as pulse outputs. When this configuration is selected, the internal encoder signal will be available at the outputs.

This can be useful in modes in which the internal encoder signal must be used as feedback to external electronics for monitoring the real-time position, or as a part of a closed-loop regulation.

This feature is especially relevant in the following 4 modes: *Velocity*, *Position*, *Analogue Torque* and *Analogue Velocity*.

A quadrature signal will appear at the A and B channel. Quadrature means that the two channels are 90 degree phase shifted either positively or negatively, which determines the actual direction of movement of the motor.

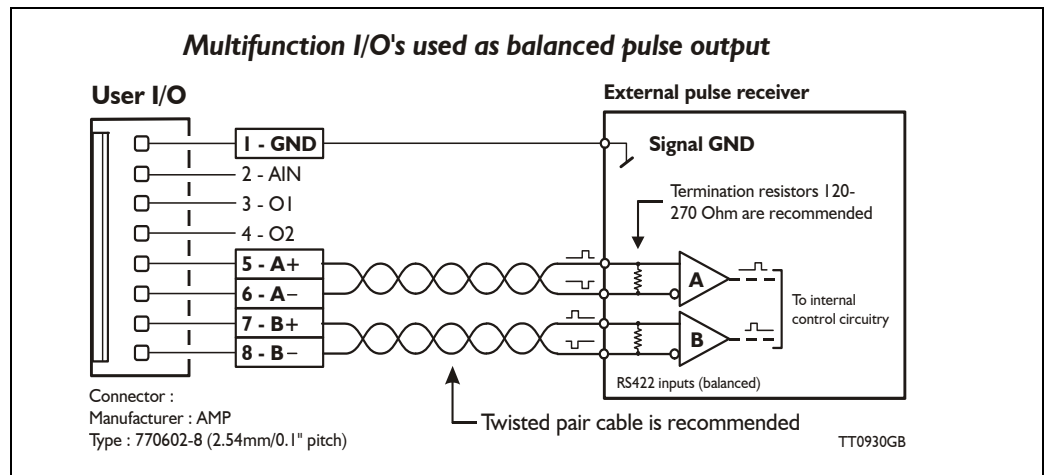

The Multifunction I/O's must be set up in MAC-Talk to function as pulse outputs.

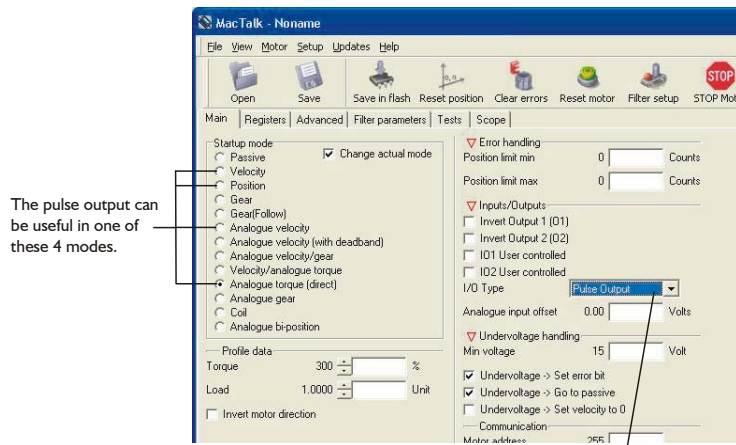

TT0929GB

The Multifunction I/O's are setup as outputs in this field

See also the respective mode descriptions for further details about functionality.

## 3.4

# User I/O

### 3.4.7 Multifunction I/O used as serial communication interface

The Multifunction I/O can be set up as a serial communication interface. When this configuration of the Multifunction I/O is selected, the A and B channels function as a receive and transmit channel via which commands to the MAC motor can be transmitted from, for example, a PC or PLC.

This feature can be used in all modes of operation.

The communication protocol is described in the MAC motor *Technical Reference Guide*, which must be requested separately and is not part of this user manual. See also *MacTalk communication*, page 378.

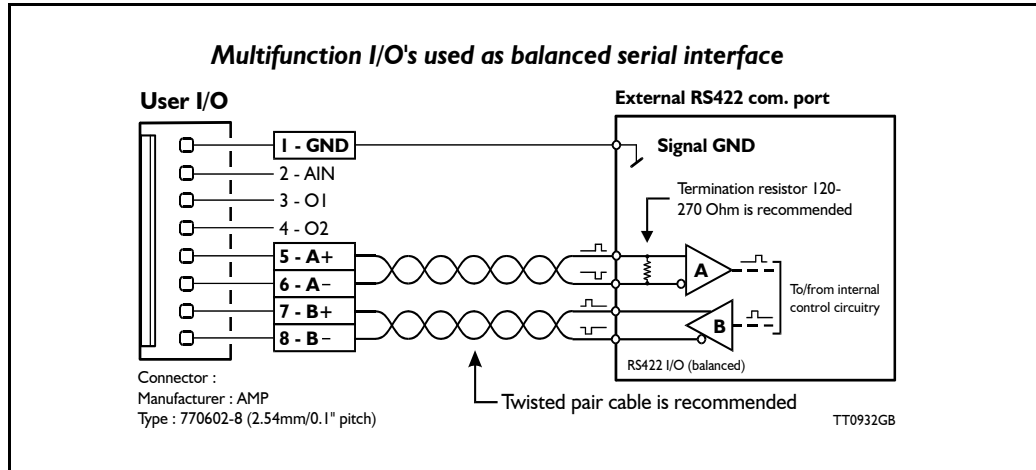

The Multifunction I/O's must be set up in MacTalk to function as a serial communication interface.

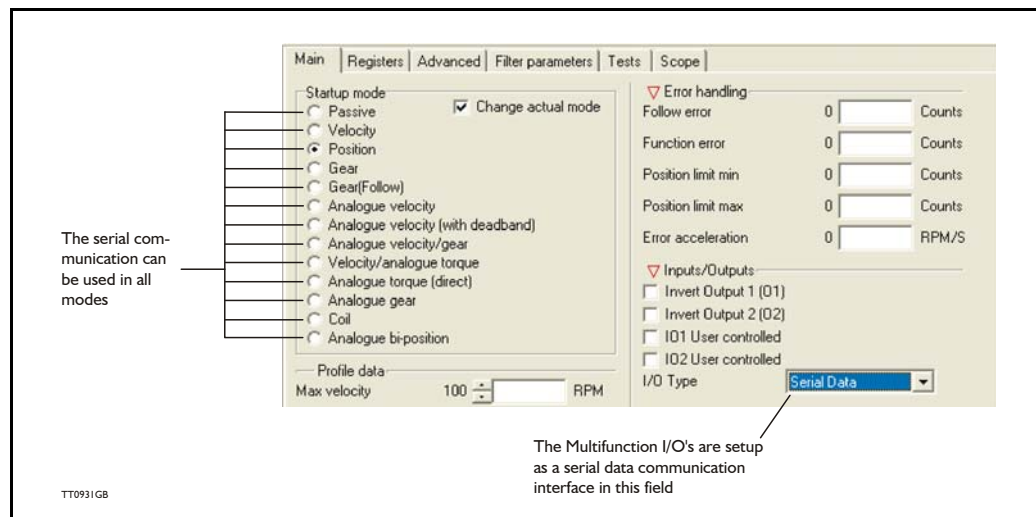



## 4.1 Expansion Module MAC00-CS



### 4.1.1 Expansion module MAC00-CS — overall description

The MAC00-CS module is the simplest expansion module in the series of modules since no electronics are included. The MAC00-CS is simply a rear plate rated for IP67, but includes cables for power and I/O signals. The MAC00-CS connects directly into the basic MAC motor with all connectors available except for the serial communication (asynchronous com port).

Applications:

- Closed loop operation with a master controller.
- “Stand alone” axis with pulse and direction input.
- Simple speed control of conveyor system or feeding mechanism.
- Dispenser systems.
- .....and many more.

MAC00-CS is available in following versions:

Type	Cable length
MAC00-CS-02	2m / 79"
MAC00-CS-10	10m / 394"
MAC00-CS-20	20m / 787"

The cable connections are as follows:

Power cable		I/O cable		
“Power supply” connector in basic motor	Wire colour	“I/O” connector in basic motor	Function	Wire colour
“P+” (Main PWR) / pin 1	Red	“GND” / pin 1	Signal ground	White/Orange
“P-” (GND) / pin 2	Black	“AIN” / pin 2	Analogue input	Orange
	Screen	“O1” / pin 3	Output 1	White/Green
		“O2” / pin 4	Output 2	Green
		“A+” / pin 5	Multifunction I/O “A+” Max 5V !	White/Blue
		“A-” / pin 6	Multifunction I/O “A-” max 5V !	Blue
		“B+” / pin 7	Multifunction I/O “B+” max 5V !	White/Brown
		“B-” / pin 8	Multifunction I/O “B-” max 5V !	Brown
The housing (GND) of the motor is connected to the cable screen				

For details of the description of each signal and how to connect and use these, please refer to the description of the basic motor: section 3

## 4.2 Expansion Module MAC00-B1/B2/B4

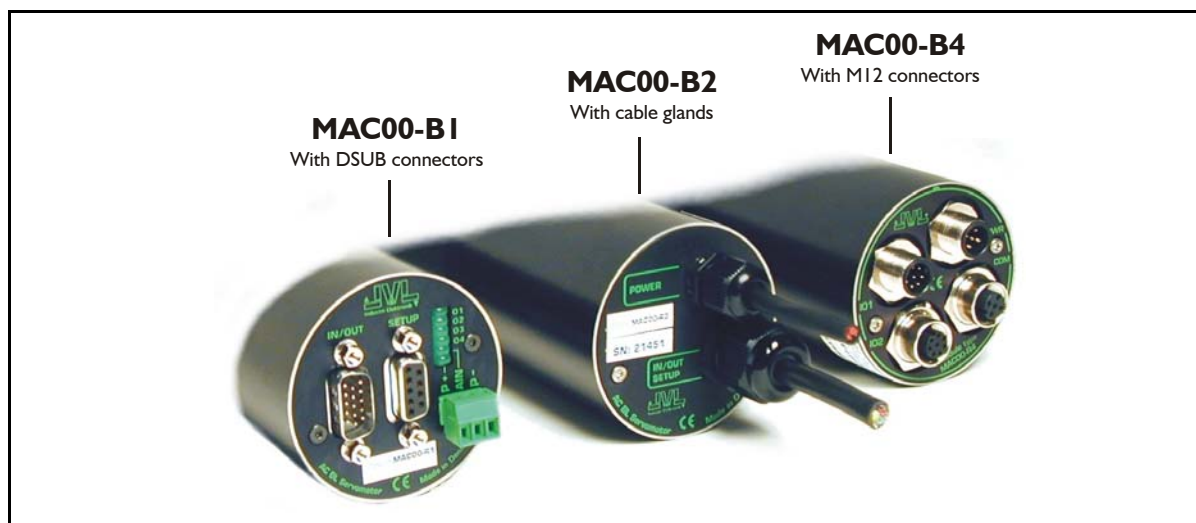

### 4.2.1 Expansion modules MAC00-B1, B2 and B4 — overall description

The expansion modules MAC00-B1, B2 and B4 can be mounted in all the standard MAC motors up to MAC3000. These modules are among the simplest and lowest cost modules in the product range. The modules contain no intelligence (microprocessor). The MAC00-B1, B2 or B4 expansion module offers an industrial interface that mates with the standard MAC motor and offers a number of feature enhancements, including:

- Different kinds of connectors for more reliability (compared to the basic motor itself).
- Full RS232 protocol support for use with standard serial cable.
- Full RS485 protocol support for multipoint communication up to 100m.
- Sourcing (PNP) outputs for status signals O1 and O2 instead of sinking (NPN).
- Only MAC00-B1: LEDs to indicate: O1, O2 output status. Zero switch (analogue input) status and Input power status.
- Only MAC00-B2 and B4: Dual supply. The main supply can be removed but the control circuitry is kept active and position data and communication are still functional.

Typical applications for these expansion modules are:

- Closed loop systems with an overall controller involved.
- Replacement for pneumatic cylinders using the “Air Cylinder mode”
- Dispenser systems
- Simple velocity or torque control via +/-10V input.
- Machine adjustment/setup by sending RS232 or RS485 commands.

The B1, B2 and B4 are equivalent except for the following hardware differences:

Type	Protection Class	Connectors			Dual Supply
		I/O and interface	Power supply	LEDs at I/O	
<b>MAC00-B1</b>	IP42	DSUB 9 pole	3 pole Phoenix	Yes	No
<b>MAC00-B2</b>	IP67/IP65*	Cable glands	Cable glands	No	Yes
<b>MAC00-B4</b>	IP67/IP65*	M12	M12	No	Yes

Note\*: IP65 on MAC400-800

## 4.2 Expansion Module MAC00-B1/B2/B4

### 4.2.2 General hardware aspects

All internal and external main connections can be seen in the illustration below. Please note that a few features are only available in MAC00-B4 and partly in B2.

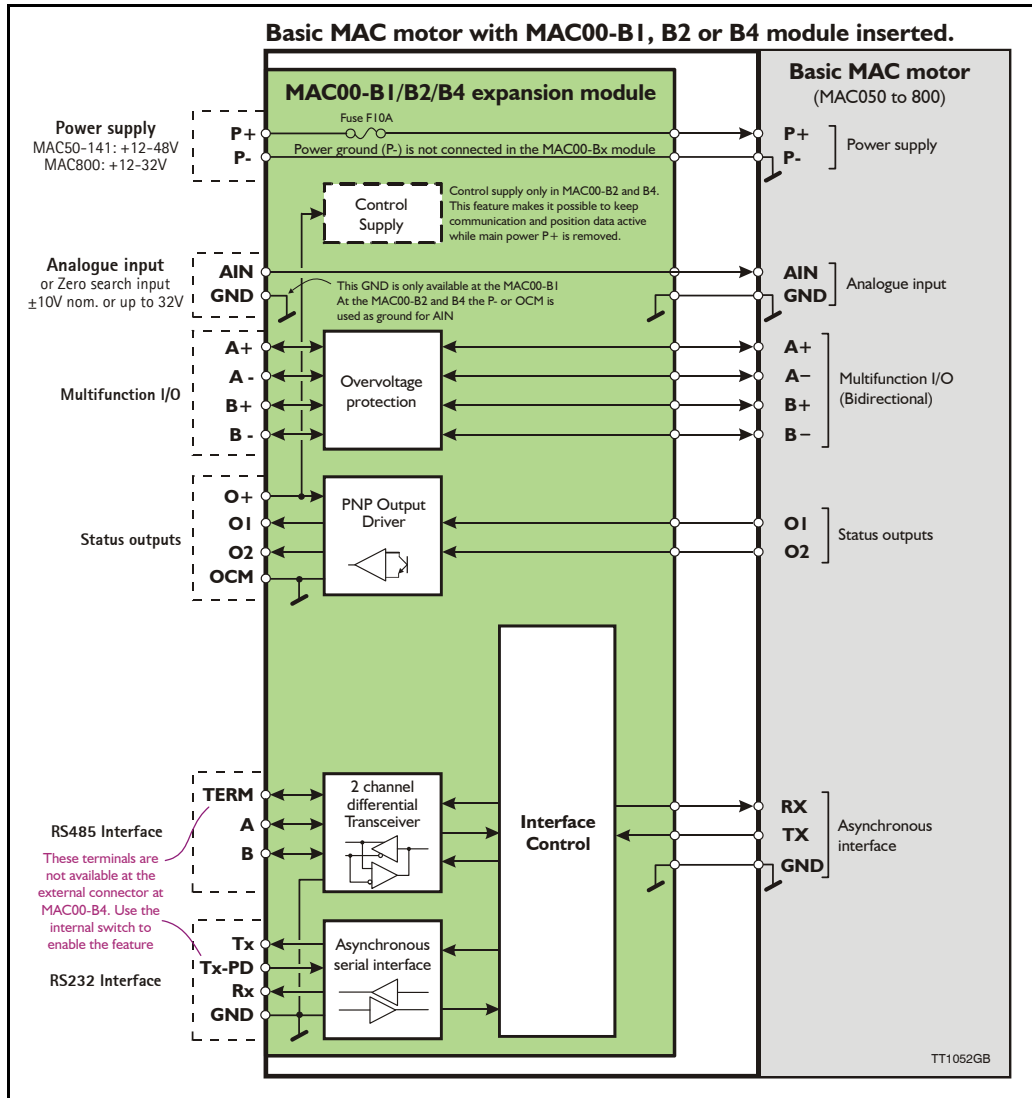

### 4.2.3 General hardware description

The MAC00-B1, B2 and B4 modules offer the following external connections.

- **Power supply (P+/P-)**  
These terminals are used for the main supply of the motor. A voltage between +12 and 48VDC (MAC50-141) and +12-32VDC (MAC400-800) must be connected.
- **Analogue input (AIN)**  
The analogue input is used either as an analogue input or digital input. When used as an analogue input, it can control velocity, torque or position depending on which mode is set for motor operation. When used for digital input, it can be used in position-related modes for the external zero-search sensor. Also in "Air Cylinder Mode" the analogue input is used as a trigger input.  
For a functional description, please refer to *General Analogue input (AIN) description when using MAC00-Bx*, page 123.  
(continued)



## 4.2 Expansion Module MAC00-B1/B2/B4

---

- **Multifunction I/O (A+,A- , B+ and B-)**

The functionality of these terminals is the same as for the basic MAC motor. They can be set up in 3 different configurations.

  - Pulse inputs - for functional description please refer to *Multifunction I/O used as pulse inputs, page 114* and *General description: "General description: "Multifunction I/O" when using a Bx module, page 126*
  - Pulse outputs - for functional description please refer to *Multifunction I/O used as pulse outputs, page 115* and
  - RS422 interface - for functional description please refer to *Multifunction I/O general description, page 113*.

**Important !:**  
Remember to configure "I/O type" as "Pulse Input" in MacTalk if none of the 4 terminals A+, A-, B+ and B- is used (the multifunction I/O's). This must be done to avoid random function of the motor since the multifunction I/Os are defined as "Serial data" as default.
- **Status outputs (O1, O2, O+, and OCM)**

The status outputs O1 and O2 (PNP outputs) indicate the actual status of the MAC motor.

  - O1** This output functions as an "In Position" or "at velocity" output depending on which operating mode is selected. The position interval can be set up using the MacTalk program.
  - O2** This output is normally passive but if an unrecoverable error occurs, it will be activated to indicate that normal operation of the motor has been interrupted and no further operation is possible until a reset or power down has been made.
- **RS485 Interface (A-, B+ and GND)**

Serial balanced interface for connection to a PC or a controller. The protocol is similar to the RS232 or USB interface, which means that all registers/parameters in the motor can be monitored or changed. The RS485 is recommended for longer distances or in noisy environments.
- **RS232 Interface (Rx, Tx and GND)**

Serial unbalanced interface for connection to a PC or a controller. The protocol is similar to the USB or RS485 interface, which means that all registers/parameters in the motor can be monitored or changed. RS232 is not recommended for long distances (> 10m).

The MAC motor uses "binary" communication protocol which makes it possible to access all the internal registers. Please consult *MacTalk communication, page 378* for further details.

## 4.2 Expansion Module MAC00-B1/B2/B4

### 4.2.4 General power supply description

The power supply must be connected to the terminals marked P+ and P-.

#### MAC50, 95, 140 or 141:

A supply voltage in the range 12VDC to 48VDC can be used. However the maximum speed of the motor (4000 RPM) is based on 48VDC. A lower voltage will decrease the speed/torque performance, and in general it is not recommended to run the motor at more than 2000 RPM if, for example, 24VDC is used as the supply.

Optionally, the MAC00-B2 and B4 modules also offer a control voltage input (O+) which means that the internal control circuitry will be kept powered when the main supply (P+) is removed. See also the description: *Power supply (only MAC050 to 141)*, page 87.

#### MAC400 or 800

For the MAC400-800, the main supply is 115/230VAC connected at separate terminals. The P+ power supply terminal only serves as a supply to the internal control circuitry. The voltage must stay in the range +12-32VDC. See also the *How to connect the power supply (only MAC800)*, page 100 or *Power supply circuitry (only MAC800)*, page 99.

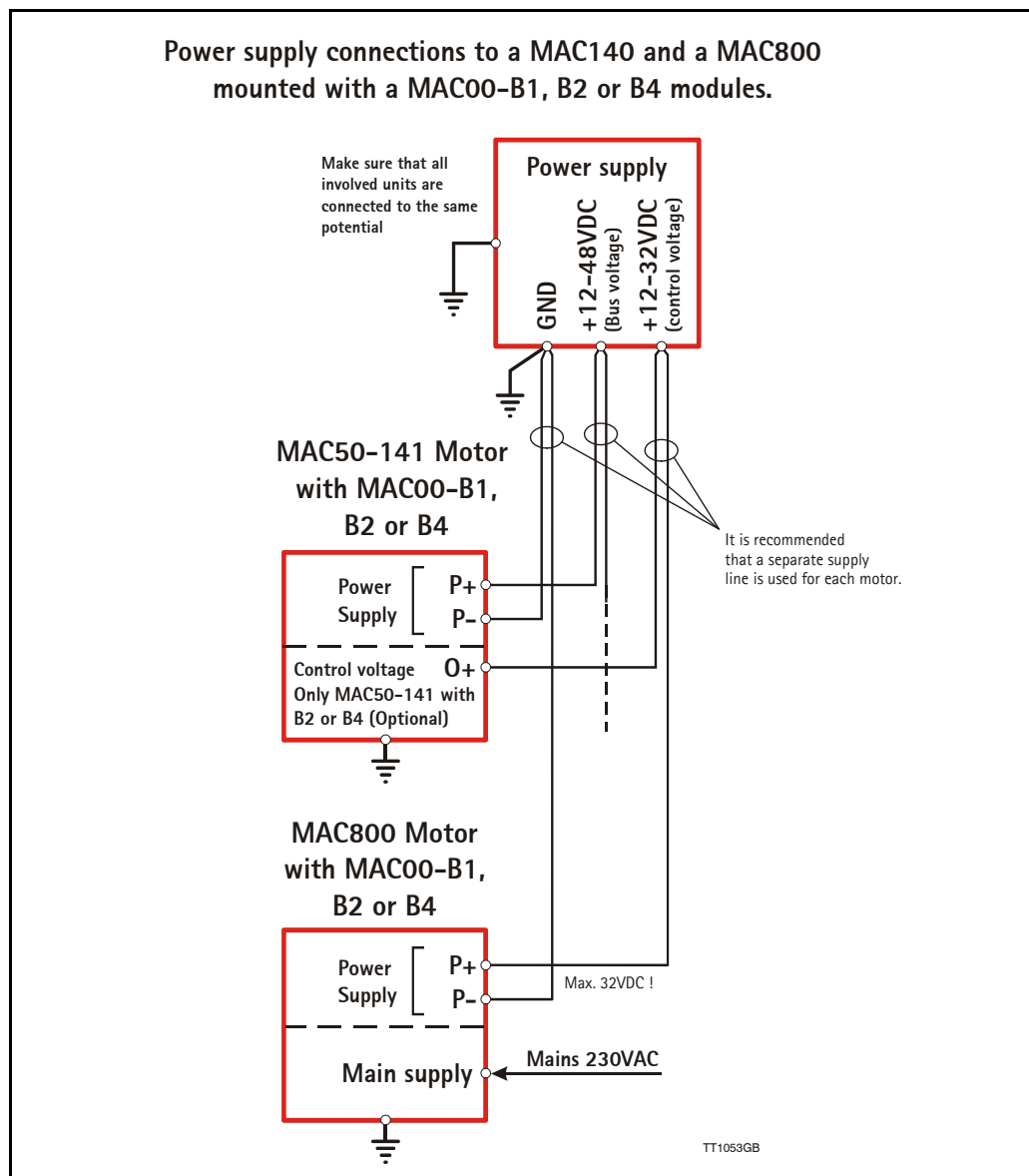

## 4.2 Expansion Module MAC00-B1/B2/B4

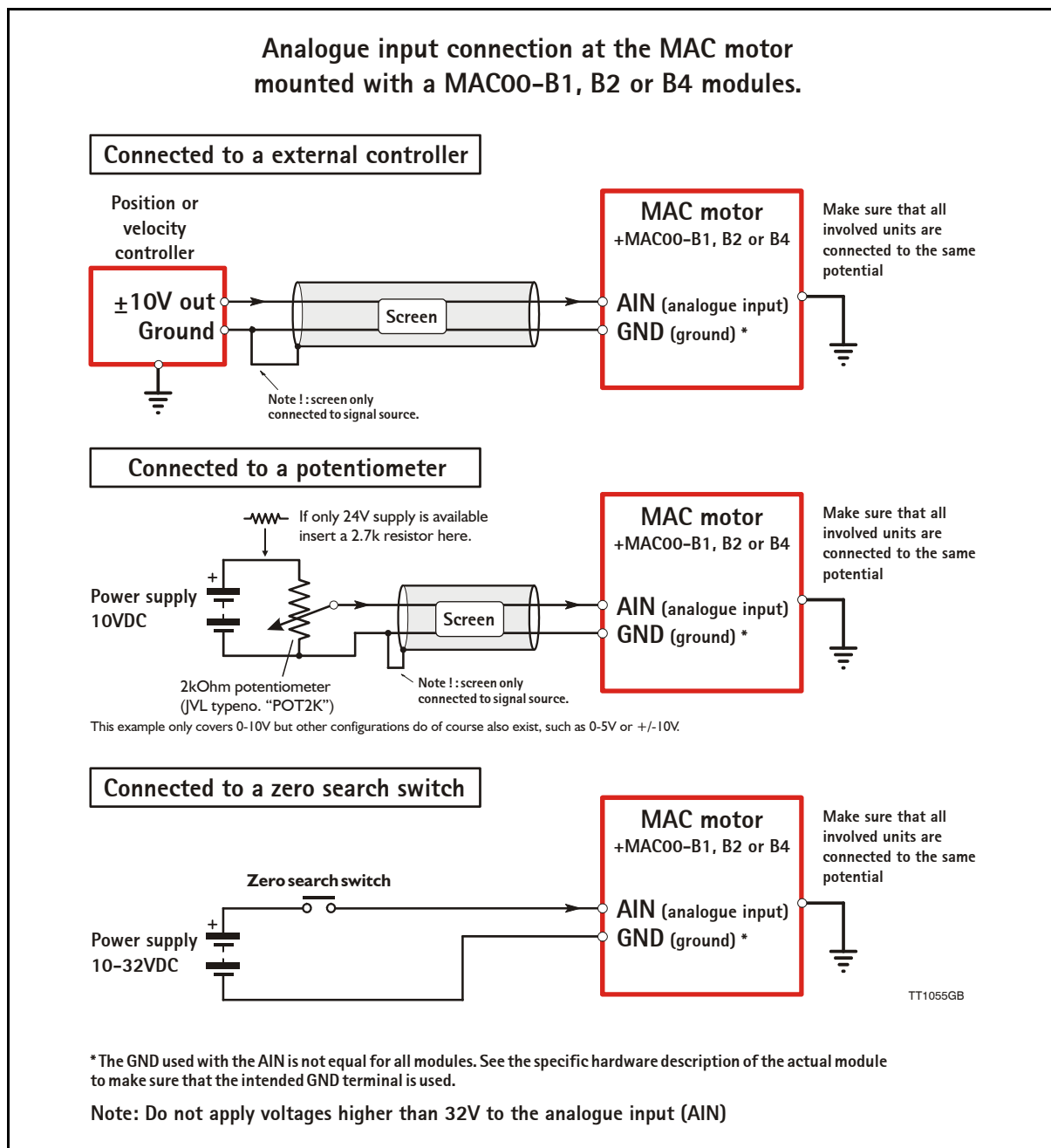

### 4.2.5 General Analogue input (AIN) description when using MAC00-Bx

When a MAC00-B1, B2 or B4 module is mounted in the MAC motor, the analogue input is available in the same manner as in the basic motor itself.

The analogue input can be used for several applications and the function of the analogue input is determined by the mode in which the motor is set to operate.

Typically the input is used for controlling the velocity, torque or position of the motor but the input is also used as digital input for *Zero search* or in "Air Cylinder Mode" where it is used as trigger input for the movement done by the motor.

For further information concerning physical connections, see the individual chapters for each module type: *General description MAC00-B1*, page 128, *General description MAC00-B2*, page 129, or *General description MAC00-B4*, page 131.

## 4.2 Expansion Module MAC00-B1/B2/B4

### 4.2.6 RS232 - General description when using a MAC00-Bx module

The RS232 interface is considered the main interface to the motor when the motor is set up using the MacTalk windows software from a PC or from any kind of controller using a RS232 interface.

*Note: The basic MAC motor does not fully support RS232 since the interface signals are only 5V levels. See also the basic description - Serial interface, page 109.*

When connecting the RS232 interface to a PC or controller, the following rules must be followed:

- 1 Ensure that Tx-PD is connected to TX on one of the units in the system. Note that the B1, B2 and B4 modules all contain a termination resistor which can be activated.
- 2 Use screened cable.
- 3 Ensure that GND is also connected.
- 4 Ensure that all units have a proper connection to safety ground (earth) in order to refer to the same potential.
- 5 Ensure that the supply lines are connected individually in order to minimise the voltage drop between the motors.
- 6 Master Controller RS485 interface:  
If available, it is strongly recommended a type with optical isolation is used.
- 7 The interface cable length should not exceed 10 metres.

#### Connectors:

Please read the individual description for the MAC00-B1, B2 or B4 to see the RS232 connector layout.

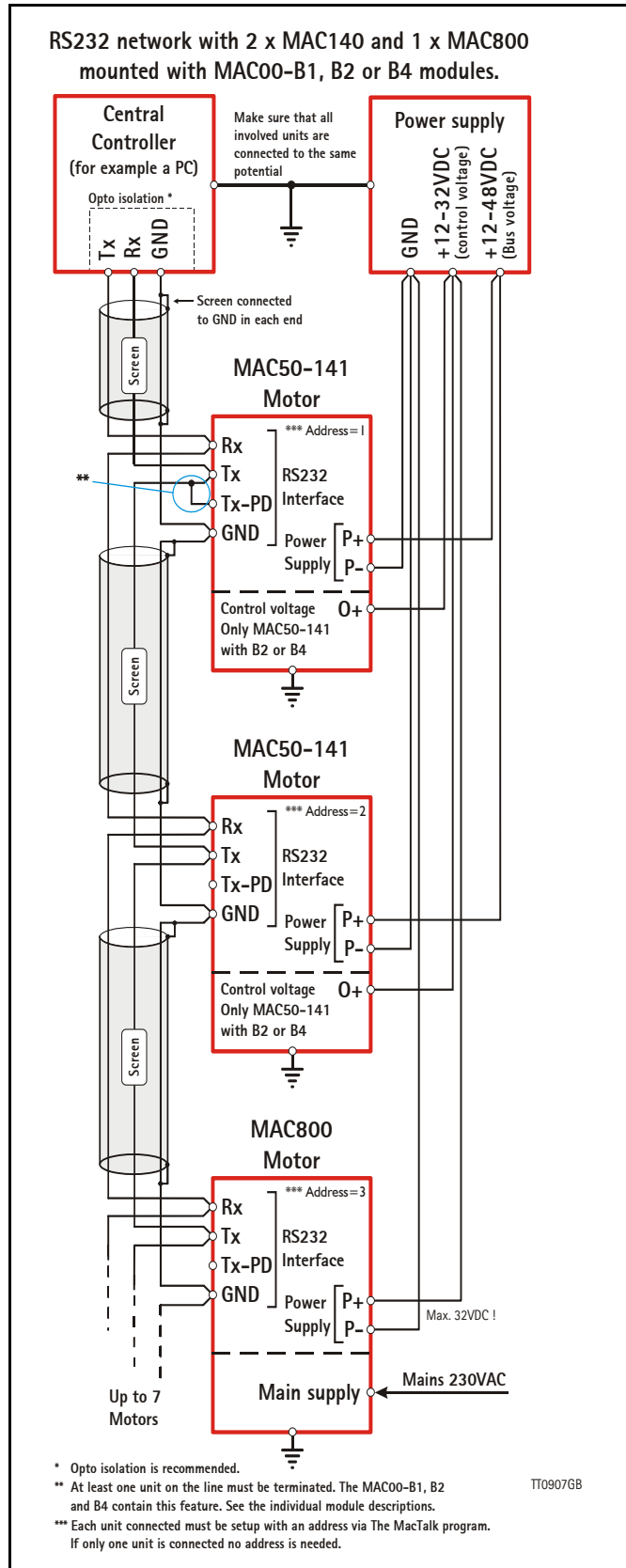

## 4.2 Expansion Module MAC00-B1/B2/B4

### 4.2.7 RS485 - General description when using a MAC00-Bx module

The RS485 offers more noise-immune communication compared to the RS232 interface. Up to 32 motors can be connected to the same line.

When connecting the RS485 interface to a central controller, the following rules must be followed:

- 1 Use twisted-pair cable
- 2 Use screened cable
- 3 Ensure that GND is also connected.
- 4 Ensure that all units have a proper connection to safety ground (earth) in order to refer to the same potential.
- 5 The last unit in each end of the network must be terminated. Note that the B1, B2 and B4 modules all contain a termination resistor which can be activated.
- 6 Ensure that the supply lines are connected individually in order to minimise the voltage drop between the motors.
- 7 Master Controller RS485 interface:  
If available, it is strongly recommended a type with optical isolation is used.

#### Connectors:

Please read the individual description for the MAC00-B1, B2 or B4 to see the connector layout.

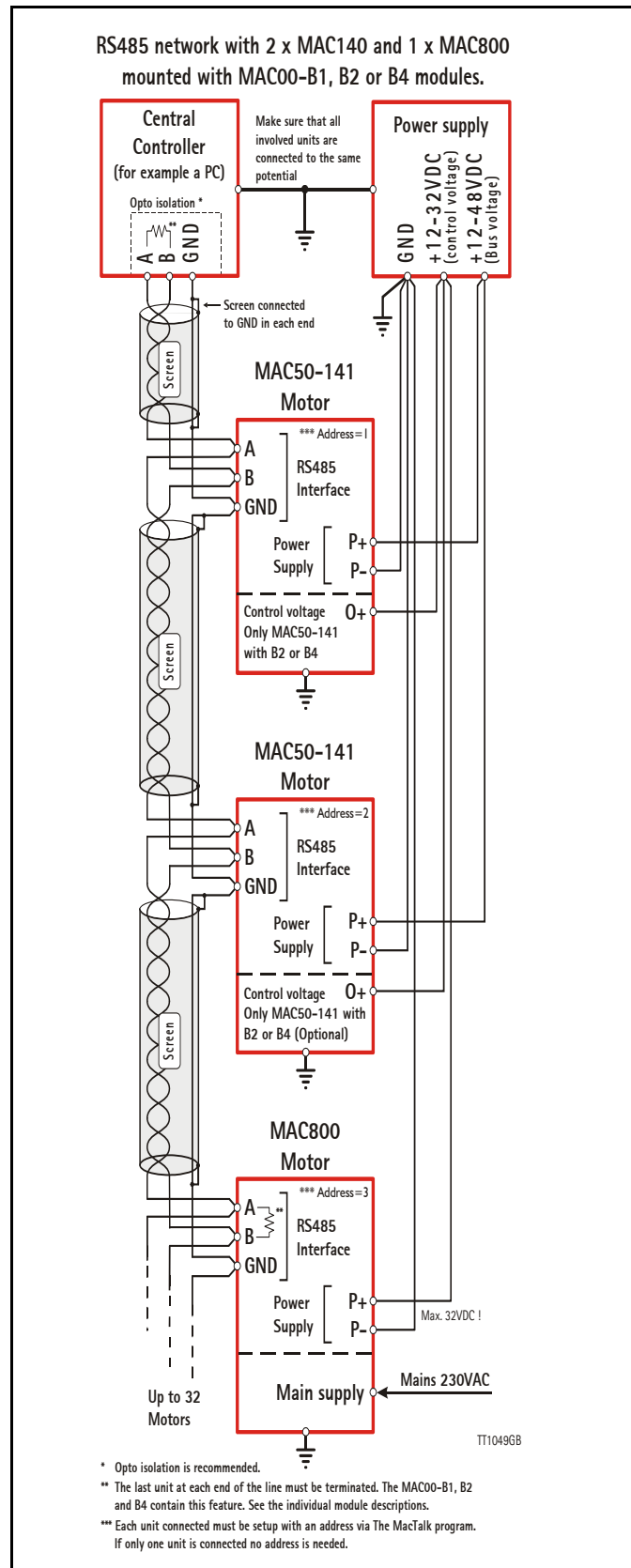

## 4.2 Expansion Module MAC00-B1/B2/B4

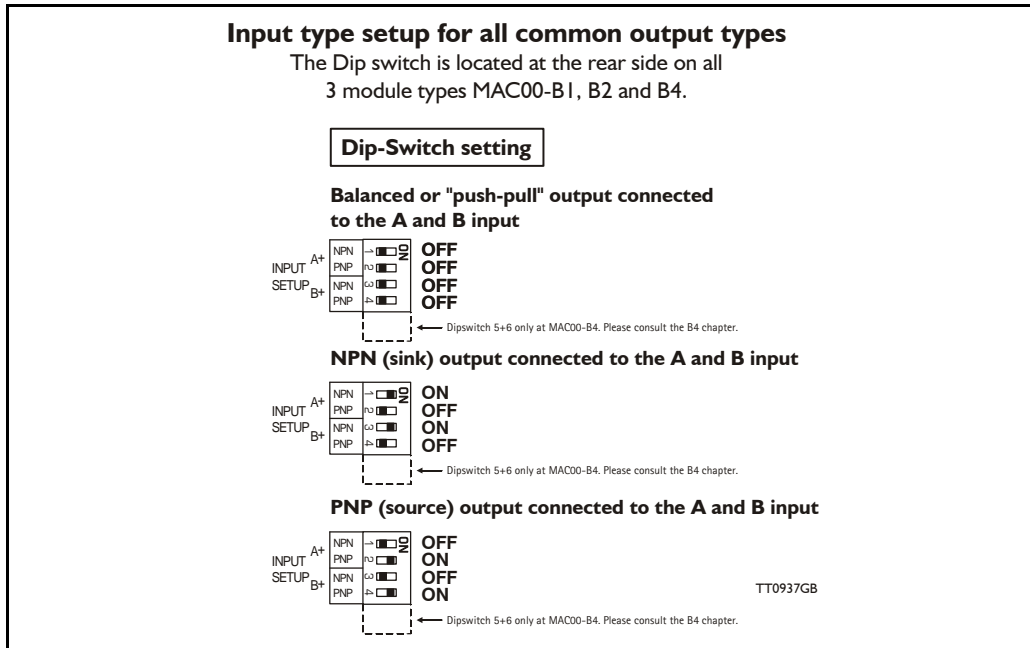

### 4.2.8 General description: "Multifunction I/O" when using a Bx module

The function of the Multifunction I/O is equal to that of the basic motor with the exception that the B1, B2 or B4 modules include an overvoltage protection and a dip-switch to set up what kind of signal source feeds the input (if the Multifunction I/O is set up as inputs).

The illustration above shows how to set up the Multifunction I/O terminals as balanced/push pull, NPN or PNP input. The illustrations below show examples of connections for each of these signal types.

### 4.2.9 Connecting an NPN signal source to the Multifunction I/O

The drawing below shows how to connect an NPN source to the MAC00-B1, B2 or B4 multifunction I/Os. The diagram shows the A channel. The B channel must be connected in the same manner. Ensure that the A- and B- terminals are unconnected in order to maintain proper function.

**Warning:** Voltages higher than 5V must under no circumstance be connected directly to the input since this will damage the input permanently.

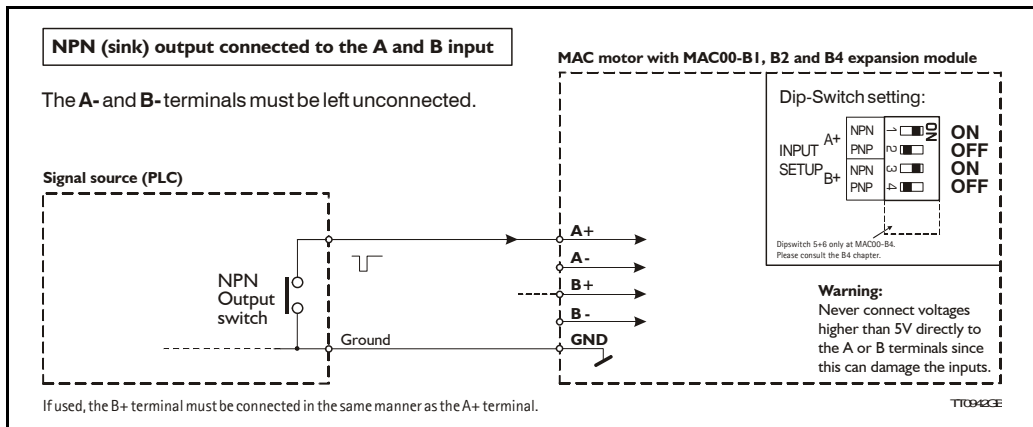

## 4.2 Expansion Module MAC00-B1/B2/B4

### 4.2.10 Connecting a PNP signal source to the Multifunction I/O

The drawing below shows how to connect a PNP source to the MAC00-B1, B2 or B4 multifunction I/Os. The diagram shows the A channel. The B channel must be connected in the same manner.

Ensure that the A- and B- terminals are unconnected in order to maintain proper function.

**Warning:** Voltages higher than 5V must under no circumstance be connected directly to the input since this will damage the input permanently. Use a proper resistor as indicated in the table below.

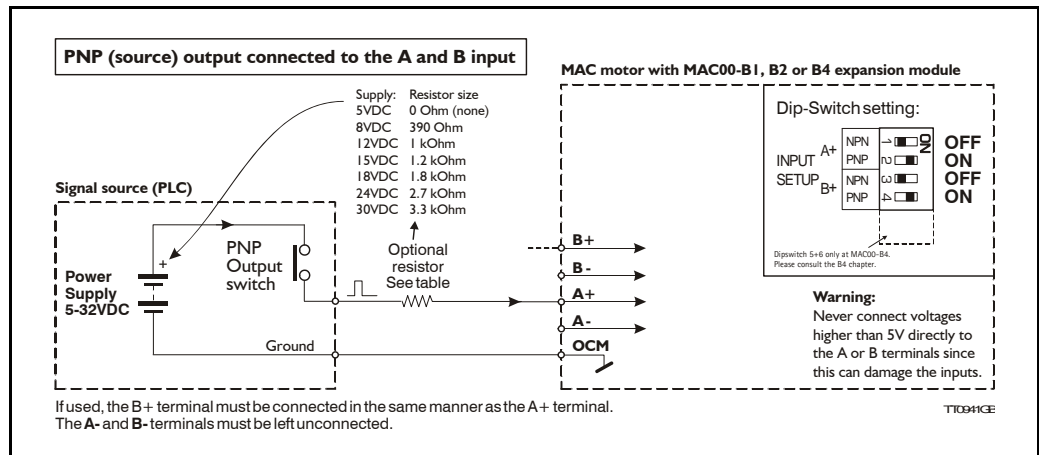

### 4.2.11 Connecting a balanced/push-pull signal to the Multifunction I/O

The drawing below shows how to connect a balanced or push-pull signal source to the MAC00-B1, B2 or B4 multifunction I/Os. Use twisted-pair cable for the balanced signals in order to ensure noise immunity.

**Note:** If inputs are used in pulse-direction format input A (A+/A-) is pulse input and input B (B+/B-) is direction input.

**Warning:** Voltages higher than 5V must under no circumstance be connected directly to the input since this will damage the input permanently. Use a proper resistor as indicated in the table below.

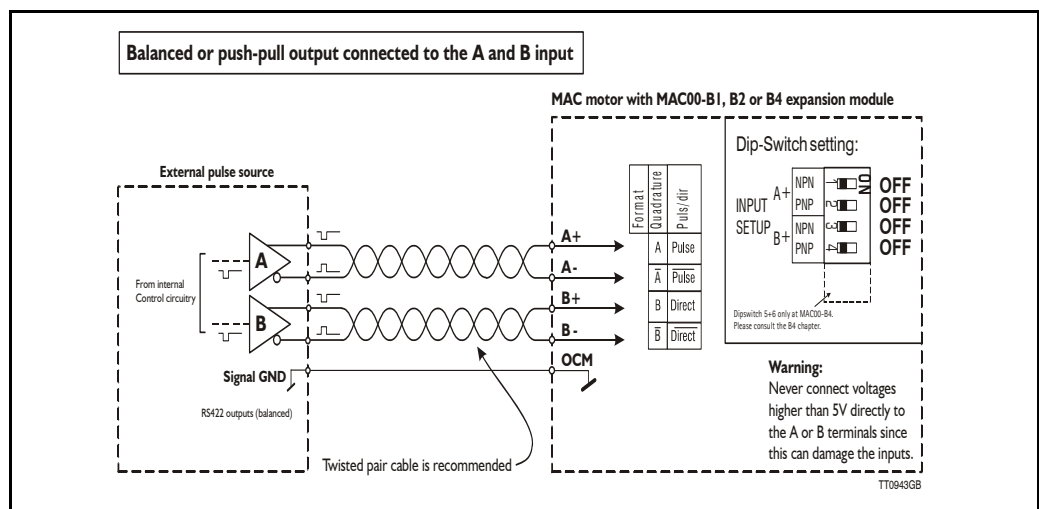

# 4.2 Expansion Module MAC00-B1/B2/B4

## 4.2.12 General description MAC00-B1

The MAC00-B1 expansion module is an industrial interface that mates with the standard MAC motor and offers a number of feature enhancements, including:

- Standard 9-pin D-SUB connectors for additional reliability.
- Addition of a Zero switch input for locating a mechanical zero point of the actuator when used in position-related modes.
- Pluggable screw terminal connector for power supply and Zero switch.
- LEDs to indicate: O1 and O2 output status, Zero switch (analogue input) status. Input power status.
- Full RS232 and RS485 protocol support for use with standard 9-pin DSUB.
- Sourcing (PNP) outputs for status signals O1 and O2 instead of sinking (NPN).

The following illustration shows all the connectors on the MAC00-B1 module.

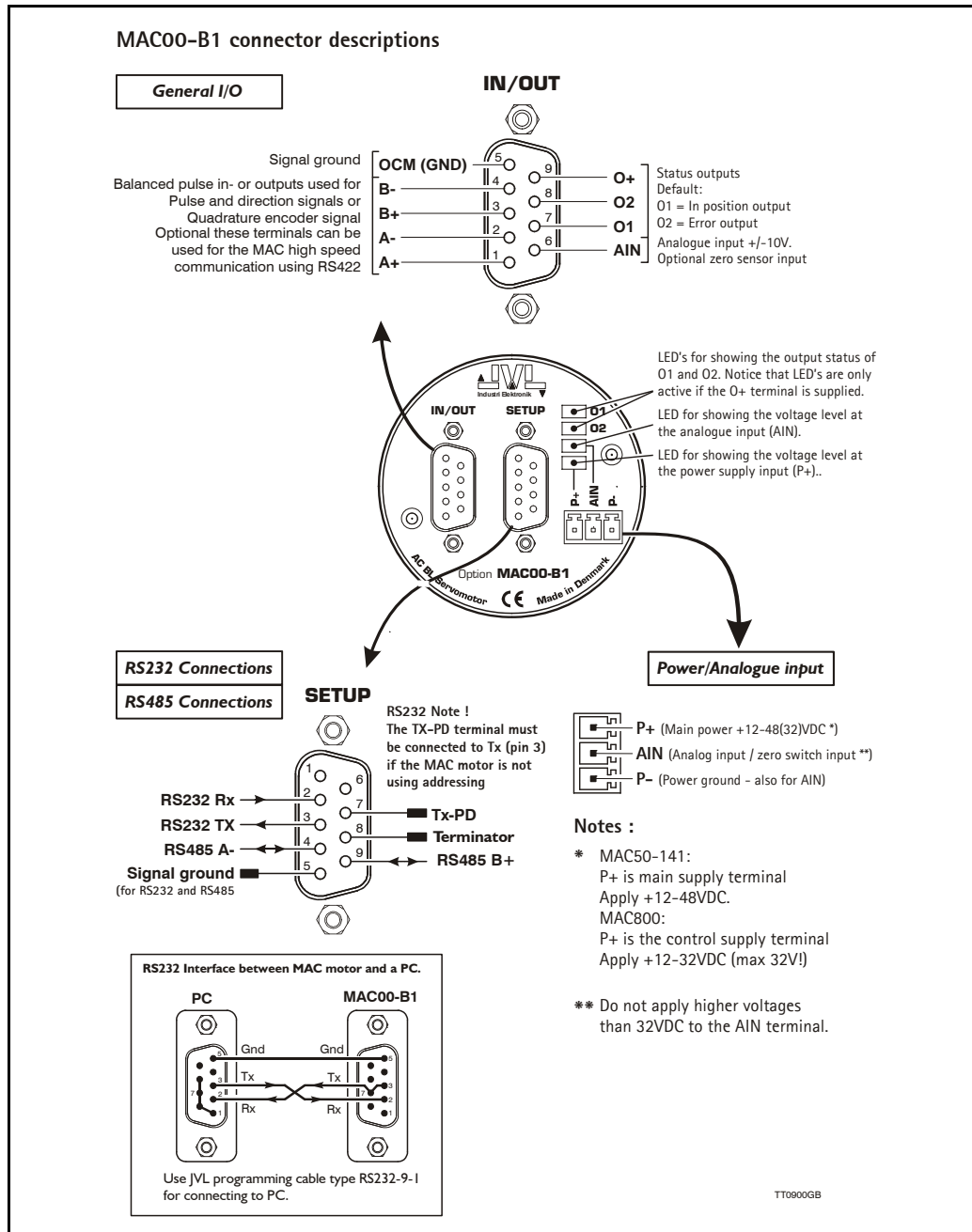



## 4.2 Expansion Module MAC00-B1/B2/B4

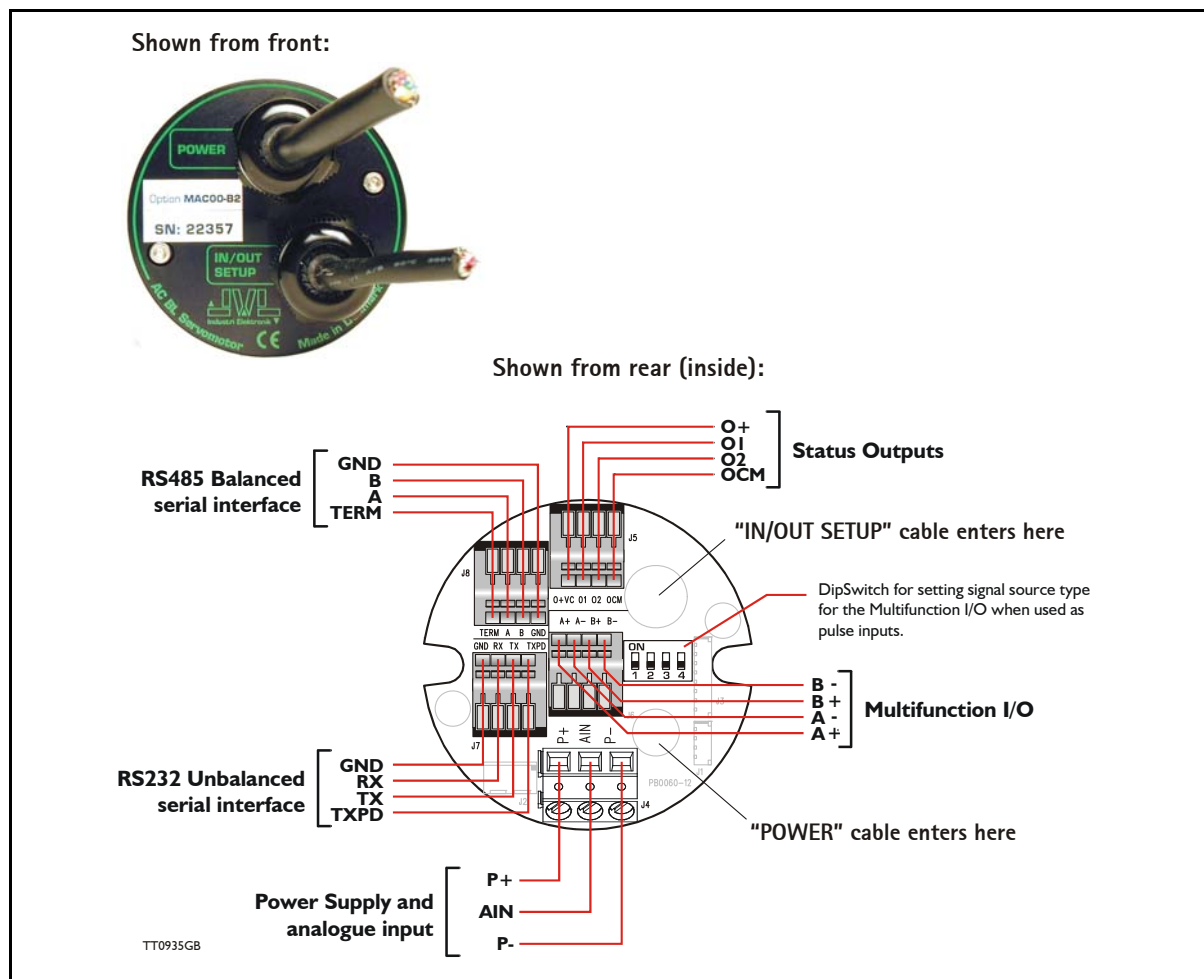

### 4.2.13 General description MAC00-B2

The MAC00-B2 expansion module is an industrial interface that mates with the standard MAC motors and offers a number of feature enhancements, including:

- IP67 protection if mounted on basic MAC050-141 motor with the IP67 option, and IP65 on MAC400-600
- Direct cable connection through sealed compression cable glands.
- Addition of a Zero switch input for locating a mechanical zero point of the actuator when used in position-related modes.
- Screw terminals (internal) for all signal lines, power supply and Zero switch.
- Full RS232 protocol support  
Note: The basic MAC motor is only equipped with a low-voltage serial interface that requires the use of the RS232-9-1-MAC option cable which has integrated electronics to boost the voltage levels.
- Full RS485 protocol support for multipoint communication up to 100m.
- Sourcing (PNP) outputs for status signals O1 and O2. The basic MAC motors offers sinking (NPN).

## 4.2 Expansion Module MAC00-B1/B2/B4

### 4.2.14 MAC00-B2 option with cables

The 'MAC00-B2' type number designation only covers the basic module without any cables.

If a number is added after the basic type number, for example MAC00-B2-10, this suffix indicates that the module is fitted with 2x10m of cable. One cable is used for the power supply and analogue input, and the other cable covers all the signal lines, i.e. RS232, RS485, status outputs and multifunction I/O. See the following tables.

Power cable (Cable 1) - Internal connector J4			
Signal name	Pin no.	Description	Wire colour
P-	3	Power supply ground	White
AIN	2	Analogue input (AIN)	Green
P+	1	Power supply +12-48VDC Nom.	Yellow / Brown

Signal cable (Cable 2) - Internal connectors J5-8			
Signal name	Pin no.	Description	Wire colour
O+	J5/1	Status Outputs. Positive supply - Max. 30VDC	Red
O1	J5/2	Status Outputs. Output 1 - PNP(sourcing) max. 25mA	Grey
O2	J5/3	Status Outputs. Output 2 - PNP(sourcing) max. 25mA	Pink
OCM	J5/4	Status Outputs. Output ground	Blue
B-	J6/1	Multifunction I/O. Terminal B-.	Brown/Green
B+	J6/2	Multifunction I/O. Terminal B+. Connect to ground (GND J7/4 or J8/4) if not used ***	White/Green
A-	J6/3	Multifunction I/O. Terminal A-.	Grey/Pink
A+	J6/4	Multifunction I/O. Terminal A+. Connect to ground (GND J7/4 or J8/4) if not used ***	Red/Blue
TXPD *	J7/1	RS232 Interface. Transmit pull-down (Connect to TX if addressing is not used).	Green
TX	J7/2	RS232 Interface. Transmit (Connect to TXPD if addressing is not used).	Yellow
RX	J7/3	RS232 Interface. Receive. Connect to ground if not used.	White
GND	J7/4	RS232 Interface. Ground for RS232	Brown
TERM **	J8/1	RS485 Interface. Terminator. Connect to "A" (J8/2) if MAC motor is the last node on the interface bus. Important: Do not connect if not used.	Purple
A-	J8/2	RS485 Interface. A terminal. Important: Do not connect if not used.	Yellow/Brown
B+	J8/3	RS485 Interface. B terminal Important: Do not connect if not used.	White/Yellow
GND	J8/4	RS485 Interface. Signal ground.	Black
Cable Screen			
The cable-screen is internally connected to motor housing. Externally it must be connected to earth.			

\* Connect to the TX terminal if the module is the **only** or the **last** node on the line in order to terminate the line.

\*\* Connect to the A terminal if the module is the **only** or the **last** node on the line in order to terminate the line.

\*\*\* Remember to configure "I/O type" as "Pulse Input" in MacTalk if none of the 4 terminals A+, A-, B+ and B- are used (the multifunction I/Os). This must be done to avoid random function of the motor since the multifunction I/Os are defined as "Serial data" by default.

**Important:** Please note that the cables are a standard type. They are not recommended for use in cable chains or where the cable is repeatedly bent. If this is required, use a special robot cable (2D or 3D cable).

## 4.2 Expansion Module MAC00-B1/B2/B4

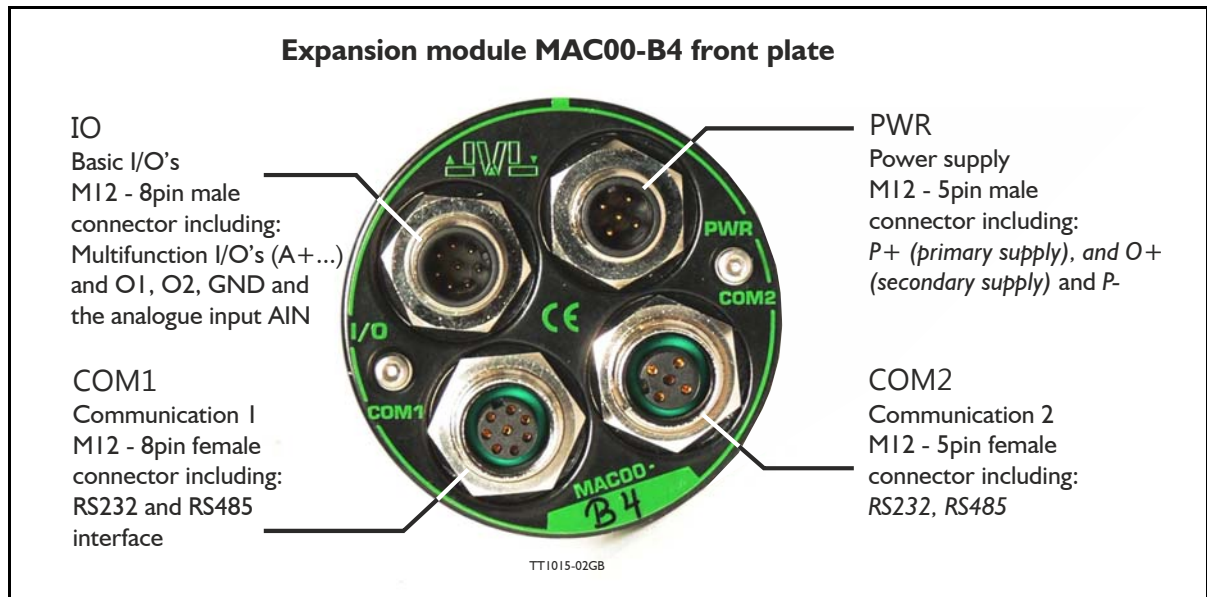

### 4.2.15 General description MAC00-B4

The MAC00-B4 expansion module is protection class IP67 (MAC050-I41) and is basically similar to the B1 and B2 modules except that it offers M12 circular industrial connectors which makes the module flexible and robust.

Additional features are:

- Secondary power supply input which can be used to keep the control core alive during emergency situations
- Dual interface connectors make it easy to daisy chain with other motors at the RS232 or RS485 interface.

### 4.2.16 Expansion MAC00-B4 hardware description

The MAC00-B4 offers IP67 (MAC050-I41) protection and M12 connectors which makes it ideal for automation applications where no additional protection is desired. The M12 connectors offer solid mechanical protection and are easy to unplug compared to the B2 module with cable glands.

The connector layout:

"PWR" - Power input. M12 - 5pin male connector				
Signal name	Description	Pin no.	JVL Cable W11000-M12F5T05N	Isolation group
P+	Main supply +12-48VDC. Connect with pin 2 *	1	Brown	1
P+	Main supply +12-48VDC. Connect with pin 1 *	2	White	1
P-	Main supply ground. Connect with pin 5 *	3	Blue	1
O+	Output supply / Control voltage +12-30VDC.	4	Black	1
P-	Main supply ground. Connect with pin 3 *	5	Grey	1

\* Note: P+ and P- are each available at 2 terminals. Make sure that both terminals are connected in order to split the supply current in 2 terminals and thereby avoid an overload of the connector.

(Continued next page)

## 4.2 Expansion Module MAC00-B1/B2/B4

<b>"IO" - Basic I/O's. M12 - 8pin male connector.</b>				
Signal name	Description	Pin no.	JVL Cable WI1000-M12 F8T05N	Isolation group
A+	Multifunction I/O terminal A+	1	White	1
A-	Multifunction I/O terminal A-	2	Brown	1
B+	Multifunction I/O terminal B+	3	Green	1
B-	Multifunction I/O terminal B-	4	Yellow	1
O1	Digital output 1 - PNP output	5	Grey	1
O2	Digital output 2 - PNP output	6	Pink	1
OCM	Ground intended to be used together with the other signals in this connector.	7	Blue	1
AIN	Analogue input +/- 10V or used for <i>Zero search</i> Use the OCM terminal (pin 7) as ground for the analogue input.	8	Red	1
<b>"COM1" - Communication connector 1. M12 - 8pin female connector.</b>				
Signal name	Description	Pin no.	JVL Cable WI1000-M12 M8T05N	Isolation group
	Not used	1	White	
RS232: TX	RS232 interface. Transmit terminal Leave open if unused.	2	Brown	1
RS232: RX	RS232 interface. Receive terminal Leave open if unused.	3	Green	1
GND	Ground intended to be used together with the other signals in this connector,	4	Yellow	1
RS485: B+	RS485 interface. Leave open if unused	5	Grey	1
RS485: A-	RS485 interface. Leave open if unused	6	Pink	1
	Not used	7	Blue	
	Not used	8	Red	
<b>"COM2" - Communication connector 2. M12 - 5pin female connector</b>				
Signal name	Description	Pin no.	JVL Cable WI1000M12 M5T05N	Isolation group
RS232 Rx	RS232 interface receive terminal. Leave open if unused	1	Brown	1
RS232 Tx	RS232 interface transmit terminal. Leave open if unused	2	White	1
RS485 B+	RS485 interface. Leave open if unused	3	Blue	1
RS485 A-	RS485 interface. Leave open if unused	4	Black	1
GND	Interface ground (same as main ground).	5	Grey	1

For complete drawings of the M12 cables please see the appendix  
*Cable drawings, page 417.*

## 4.2 Expansion Module MAC00-B1/B2/B4

### 4.2.17 MAC00-B4 dip-switch setup

The 6 pole dip-switch is placed on the rear side of the MAC00-B4 module. The following illustration shows how to set up the switch.

MAC00-B4 Dip switch settings

**Main fuse 10Amp.**  
 Replace only with:  
 Schurter type  
 "3402.0040.11"  
 or  
 Littlefuse type  
 "451-10A"

Mini dip-switch  
OFF ← ON

Dip-Switch for  
Input type setup  
Dip 5 - RS232 TxPD  
Dip 6 - RS485 Term.  
SWI

Rear side of the MAC00-B4  
expansion module

TT1031GB

**Default switch setting:**  
 As shown above. Dip 1-6 = OFF, ON, OFF, ON, ON, OFF

- Input A and B is setup for PNP outputs.
- RS232 TxPD (Transmit pull-down) is enabled.
- RS485 Termination is disabled.

**Input type setup (only switch 1-4)**

**Balanced or "push-pull" output connected to the A and B input**

<p>SWI</p>	<p><b>NPN (sink) output connected to the A and B input</b></p> <p>SWI</p>	<p><b>PNP (source) output connected to the A and B input</b></p> <p>SWI</p>
------------	---	---

**RS232 TxPD setup (only switch 5)**

One of the motors connected to an RS232 line must have this switch set to "ON" but only at one !.

SWI

**RS485 Term. setup (only switch 6)**

The last motors connected to an RS485 line must have this switch set to "ON" but only at one !.

SWI

## 4.2 Expansion Module MAC00-B1/B2/B4

### 4.2.18 Cables for the MAC00-B4

The following cables equipped with M12 connector can be supplied by JVL.

MAC00-B4 Connectors				Description	JVL Order no.	Picture
"IO" 8pin Male	"COM1" 8pin Female	"COM2" 5pin Female	"PWR" 5pin Male			
		X		RS232 Interface cable. Connects directly from MAC00-R4 to PC Length: 5m (197 inch)	RS232-M12-1-5-5	
			X	Cable (Ø5.5mm) with M12 female 5-pin connector loose wire ends 0.35mm <sup>2</sup> (22AWG) and foil screen. Length: 5m (197 inch)	WI1000-M12F5T05N	
			X	Same as above but 20m (787 inch)	WI1000-M12F5T20N	
		X		Cable with M12 male 5-pin connector loose wire ends 0.35mm <sup>2</sup> (22AWG) and screen. See also type RS232-M12-1-5-5.	WI1000-M12M5T05N	
		X		Same as above but 20m (787 inch)	WI1000-M12M5T20N	
X				Cable with M12 female 8-pin connector loose wire ends 0.22mm <sup>2</sup> (24AWG) and screen. Length: 5m (197 inch)	WI1000-M12F8T05N	
X				Same as above but 20m (787 inch)	WI1000-M12F8T20N	
	X			Cable with M12 male 8-pin connector loose wire ends 0.22mm <sup>2</sup> (24AWG) and screen. Length: 5m (197 inch)	WI1000-M12M8T05N	
	X			Same as above but 20m (787 inch)	WI1000-M12M8T20N	
<b>Protection caps. Optional if connector is not used to protect from dust / liquids.</b>						
	X	X		IP67 protection cap for M12 female connector.	WI1000-M12FCAP1	
X			X	IP67 protection cap for M12 male connector.	WI1000-M12MCAP1	

**Important:** Please note that the cables are a standard type. They are not recommended for use in cable chains or where the cable is repeatedly bent. If this is required, use a special robot cable (2D or 3D cable).

## 4.3 Expansion module MAC00-B41

Only MAC400 to 3000



### 4.3.1 Expansion module MAC00-B41 — overall description.

The expansion module MAC00-B41 can ONLY be mounted and used in following motors:

- MAC400
- MAC402
- MAC800 but only in newer versions with serial numbers >85000.
- MAC1500
- MAC3000

Please notice that the module is **NOT** recommended to be used in the **MAC050 to I41** motors since the following I/O terminals will not be active: IO1 to IO6, AIN2, (USB) and Multifunction 2 (A2/B2). All other I/O terminals will be operative.

This module is among the simplest and lowest cost modules in the product range. The modules contain no intelligence (microprocessor) meaning that all functionality is controlled via the basic motor.

The MAC00-B41 expansion module offers an industrial interface (M12 connectors) and a number of feature enhancements, including:

- Standard M12 connectors for optimum reliability
- Optical isolated communication covering RS232, RS485 and USB (2.0)
- Full RS232 protocol support for use with standard serial cable.
- Full RS485 protocol support for multipoint communication up to 100m.
- 6 high speed I/O channels that individually can be used as inputs or outputs. Each channel can (when used as output) source up to 300mA.
- Dual supply. The main supply can be removed but the control circuitry is kept active and position data and communication are still functional.
- Standard M12 connectors for optimum reliability

#### Typical applications for these expansion modules are:

- Closed loop systems with an overall controller involved.
- Replacement for pneumatic cylinders using the “Air Cylinder mode”
- Dispenser systems.
- Machine adjustment/setup by sending RS232 or RS485 commands.
- Standalone PLC with user program stored in the basic motor.

## 4.3 Expansion module MAC00-B41

Only MAC400 to 3000

### 4.3.2 Overall hardware description

All internal and external main connections can be seen in the illustration below.

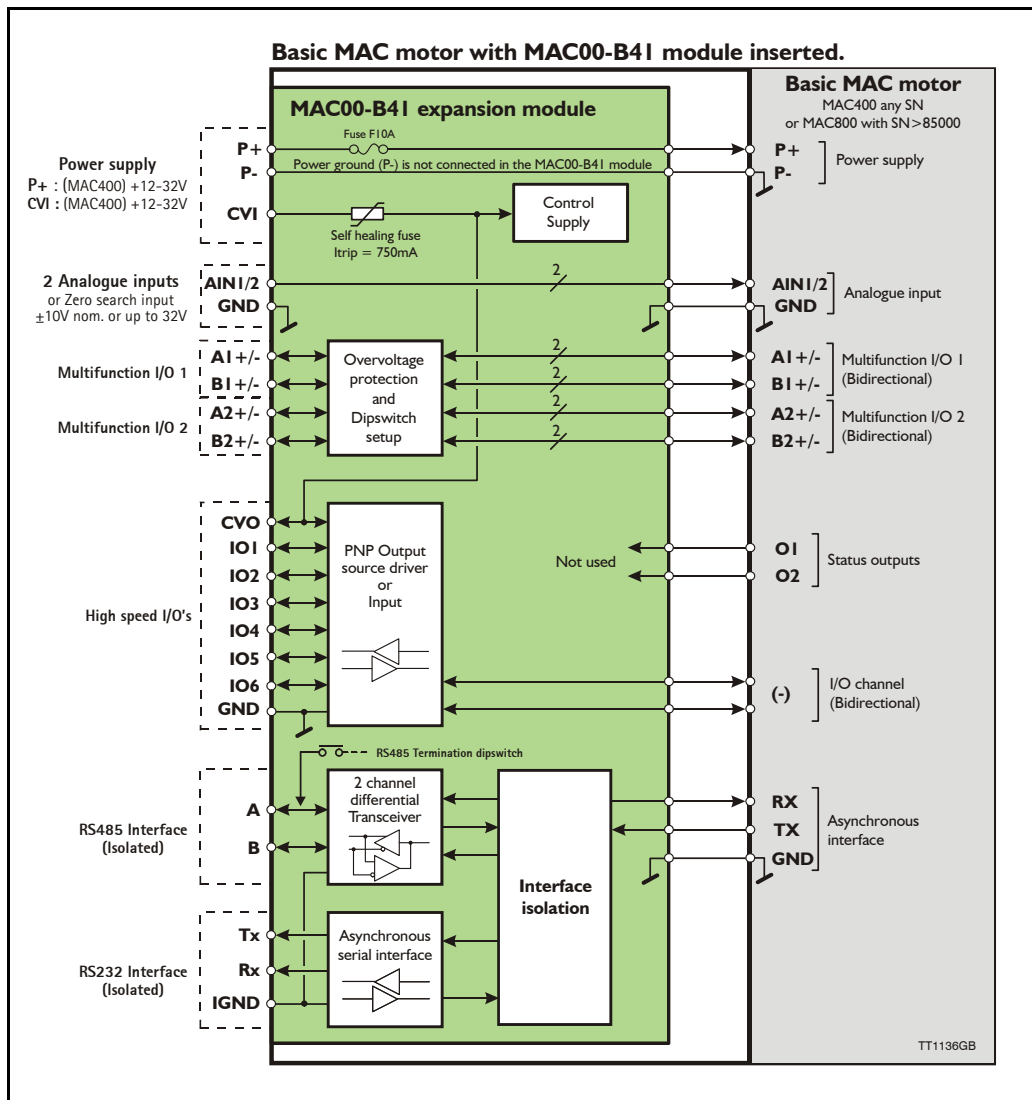

### 4.3.3 General hardware description

The MAC00-B41 module offers the following external connections.

- Power supply (P+/P-/CVI)**  
 These terminals are used for the main supply of the motor. A voltage between +12 and 32VDC (MAC400, MAC402, MAC800, MAC1500 and MAC3000) must be connected.
- Analogue inputs (AIN1 and AIN2)**  
 The analogue inputs are used either as analogue input or digital input. The primary analogue input is AIN1. When used as analogue input, it can control velocity, torque or position depending on which mode is set for motor operation. When used for digital inputs, it can be used in position-related modes for the external zero-search sensor. Also in "Air Cylinder Mode" the analogue input is used as a trigger input. For a functional description, please refer to *Analogue input, page 110*.  
 (continued)



## 4.3 Expansion module MAC00-B41

Only MAC400 to 3000

- **Multifunction I/O 1 and 2 (A1±, B1±, A2± and B2±)**  
The functionality of these terminals is the same as for the basic MAC motor. They can be set up in 3 different configurations.
  - Pulse inputs - for functional description please refer to *Multifunction I/O used as pulse inputs, page 114* and *General description: "Multifunction I/O" when using a Bx module, page 126*
  - Pulse outputs - for functional description please refer to *Multifunction I/O used as pulse outputs, page 115* and
  - RS422 interface - for functional description please refer to *Multifunction I/O used as serial communication interface, page 116*.

### Important !:

Remember to configure "I/O type" as "Pulse Input" in MacTalk if none of the 8 terminals A1/2+, A1/2-, B1/2+ and B1/2- is used (the multifunction I/O's). This must be done to avoid random function of the motor since the multifunction I/Os are defined as "Serial data" as default.

- **High speed I/O's (IO1, IO2, IO3, IO4, IO5, IO6, CVO, and GND)**  
Each of the high speed IO's can be used as either an input or as an output. The I/O's can be read or set from the serial interface (RS232 or RS485) or they can be operated from the user program stored in the motor.
- **RS485 Interface (A-, B+ and GND)**  
Serial balanced interface for connection to a PC or a controller. The protocol is similar to the RS232 or USB interface, which means that all registers/parameters in the motor can be monitored or changed. The RS485 is recommended for longer distances or in noisy environments.
- **RS232 Interface (Rx, Tx and GND) and USB interface.**  
Serial unbalanced interface for connection to a PC or a controller. The protocol is similar to the RS485 interface, which means that all registers/parameters in the motor can be monitored or changed. RS232 is not recommended for long distances (> 10m) and USB is not recommended for distances > 2m.

The MAC motor uses "binary" communication protocol which makes it possible to access all the internal registers. Please consult *MacTalk communication, page 378* for further details.

### 4.3.4 Hardware overview

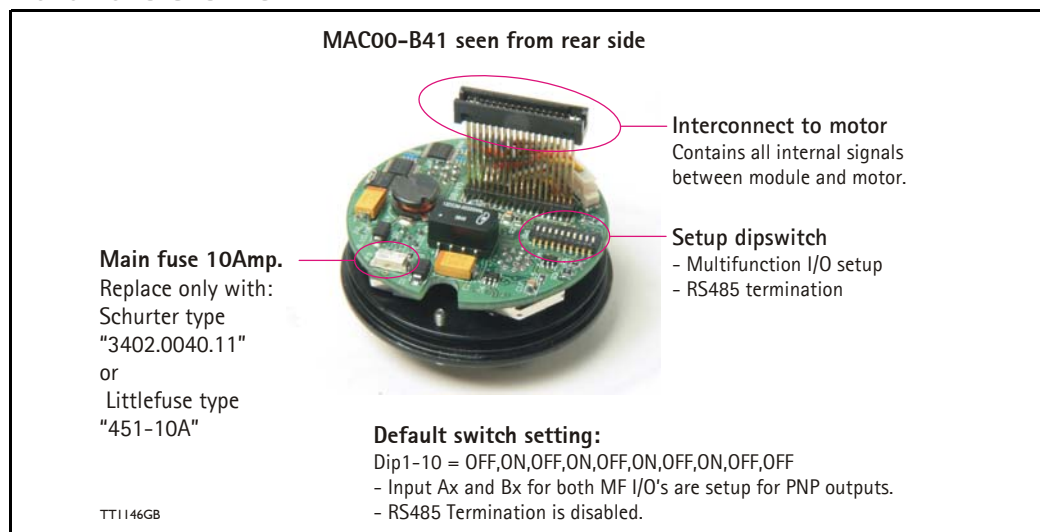

## 4.3 Expansion module MAC00-B41

Only MAC400 to 3000

### 4.3.5 General power supply description

The MAC00-B41 module can be used in the MAC400, MAC402, MAC800, MAC1500 and MAC3000 motor.

Notice that only MAC800 motors with serial numbers higher than 85000 support the B41 module. The diagram below shows how to connect power to a MAC400 motor mounted with a MAC00-B41.

Please notice that the voltage connected to P+ and/or CVI must stay in the range +12-32VDC. Precautions must therefore be taken if the system also contains MAC50, 95, 140 or 141 which may require 48VDC in order to reach maximum motor speed.

See also the general power supply description *Power Supply*, page 87.

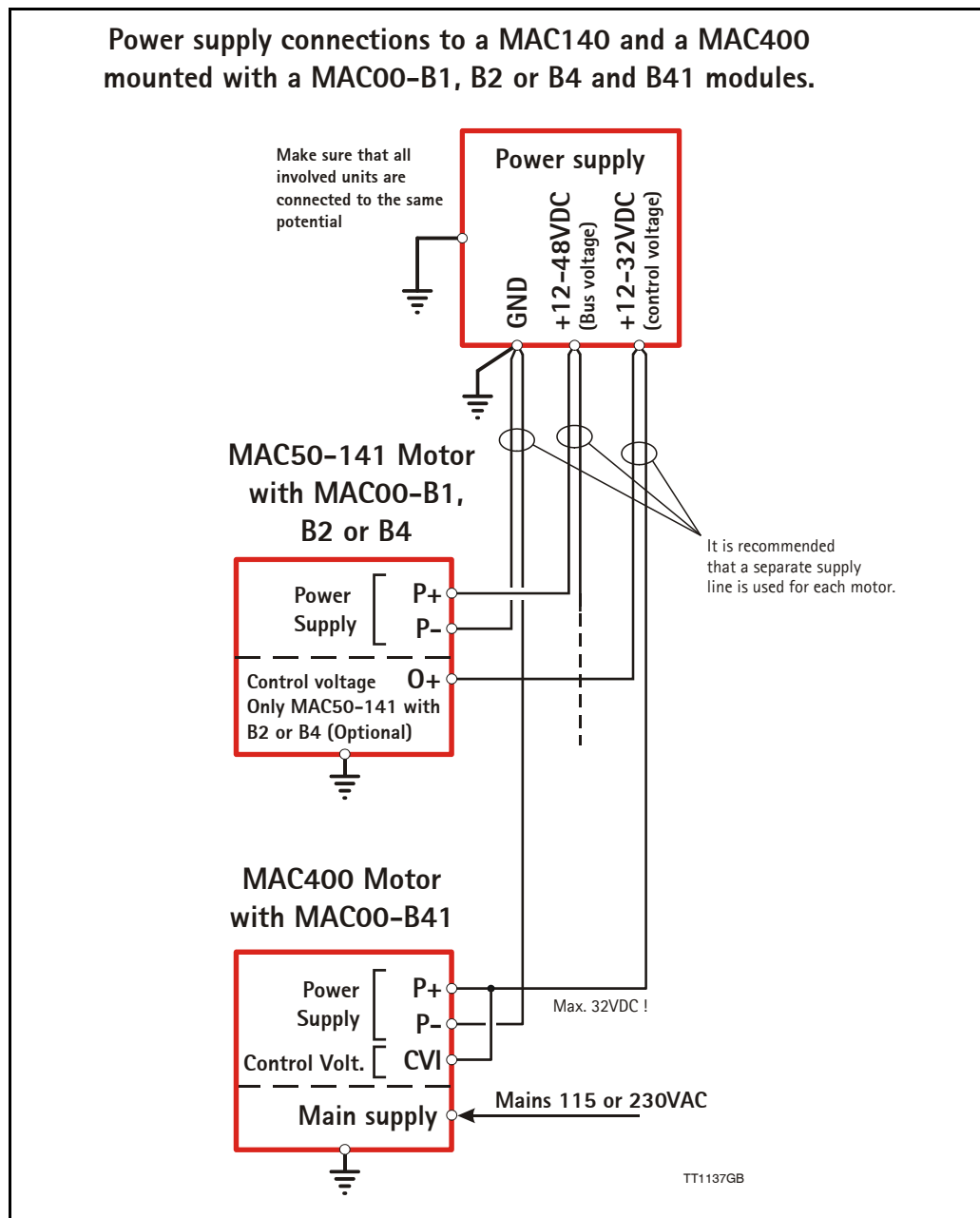

## 4.3 Expansion module MAC00-B41

Only MAC400 to 3000

### Analogue input connection at the MAC motor mounted with a MAC00-B41 module.

#### Connected to a external controller

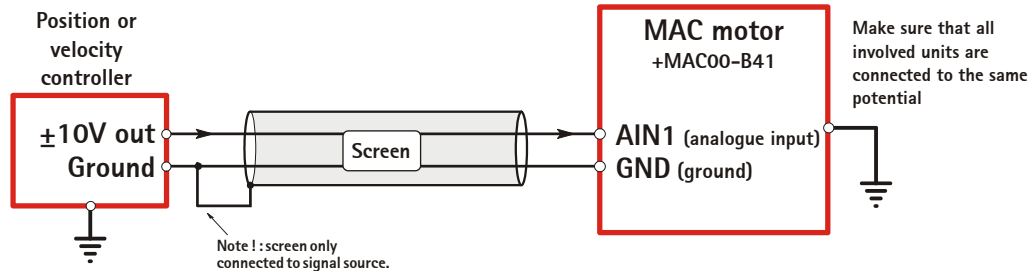

#### Connected to a potentiometer

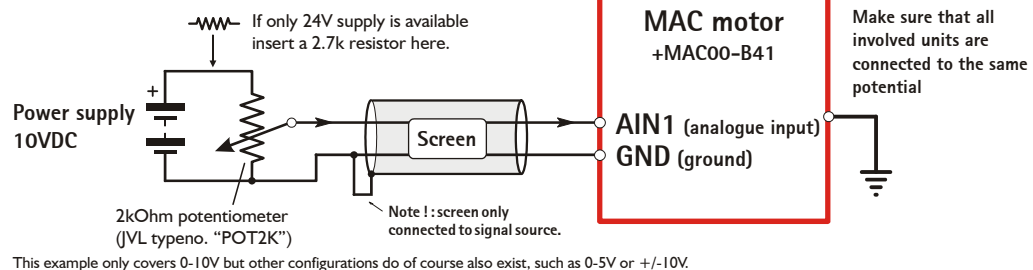

#### Connected to a zero search switch

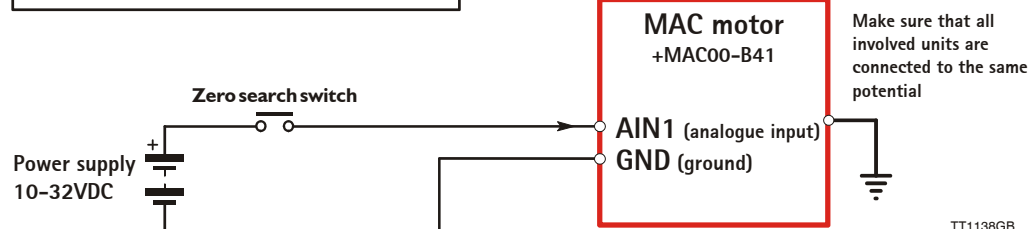

TT1138GB

Note: Do not apply voltages higher than 32V to the analogue input (AIN)

### 4.3.6 Using the analogue inputs (AIN1 or AIN2).

When a MAC00-B41 module is mounted in the MAC400 motor, the analogue inputs is available in the same manner as in the basic motor itself.

The analogue inputs can be used for several applications and the function of the analogue input is determined by the mode in which the motor is set to operate.

Typically the inputs is used for controlling the velocity, torque or position of the motor but the input is also used as digital input for *Zero search* or in "Air Cylinder Mode" where it is used as trigger input for the movement done by the motor.

For further information concerning physical connections, see the *Expansion MAC00-B41 connector description*, page 149.

## 4.3 Expansion module MAC00-B41

Only MAC400 to 3000

### 4.3.7 RS232 - General description when using the MAC00-B41 module

The RS232 interface is considered the main interface to the motor when the motor is set up using the MacTalk windows software from a PC or from any kind of controller using a RS232 interface.

*Note: The basic MAC motor does not fully support RS232 since the interface signals are only 5V levels. See also the basic description - Serial interface, page 109.*

When connecting the RS232 interface to a PC or controller, the following rules must be followed:

- 1 Only one motor can be connected at the interface line. Use the RS485 if multiple units have to be connected at the same time.
- 2 Use screened cable.
- 3 Ensure that IGND (interface ground) is also connected.
- 4 Ensure that all units have a proper connection to safety ground (earth) in order to refer to the same potential.
- 5 The RS232 interface cable length should not exceed 10 metres.

#### Connectors:

To see the specific connector pin-out please see the chapter *Expansion MAC00-B41 connector description, page 149*.

A finished RS232 cable also exist. Please see *Cables for the MAC00-B41, page 151*

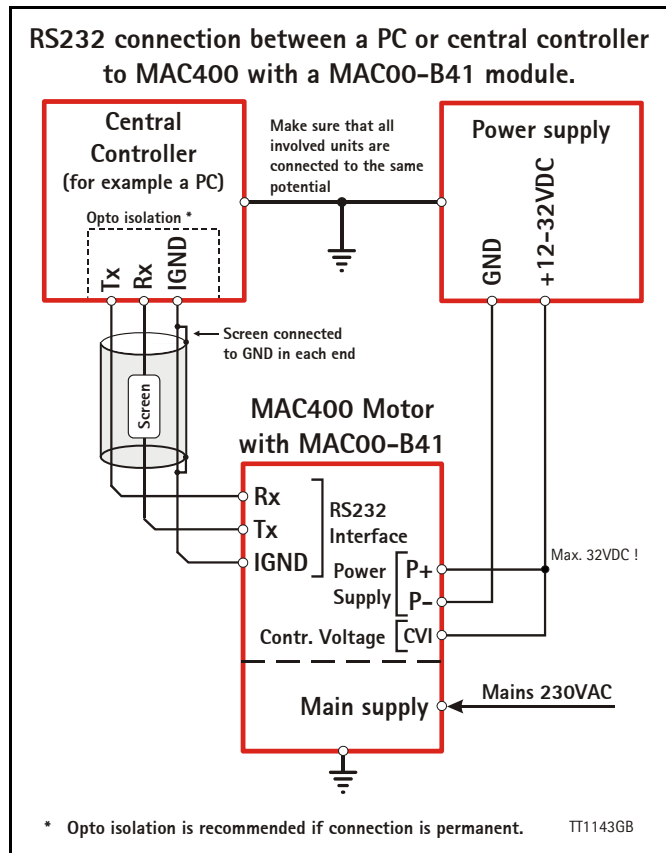

## 4.3 Expansion module MAC00-B41

Only MAC400 to 3000

### 4.3.8 RS485 - General description when using a MAC00-Bx module

The RS485 offers more noise-immune communication compared to the RS232 interface. Up to 32 motors can be connected to the same line. The RS485 interface in the MAC00-B41 module is galvanically isolated. When connecting the RS485 interface to a central controller, the following rules must be followed:

- 1 Use twisted-pair cable
- 2 Use screened cable
- 3 Ensure that GND is also connected.
- 4 Ensure that all units have a proper connection to safety ground (earth) in order to refer to the same potential.
- 5 The last unit in each end of the network must be terminated. Note that the B1, B2 and B4, B41 modules all contain a termination resistor which can be activated.
- 6 Ensure that the supply lines are connected individually in order to minimise the voltage drop between the motors.
- 7 Master Controller RS485 interface:  
If available, it is strongly recommended a type with optical isolation is used.

#### Connectors:

To see the specific connector pin-out please see the chapter *Expansion MAC00-B41 connector description, page 149*. A finished RS485 cable also exist. Please see *Cables for the MAC00-B41, page 151*

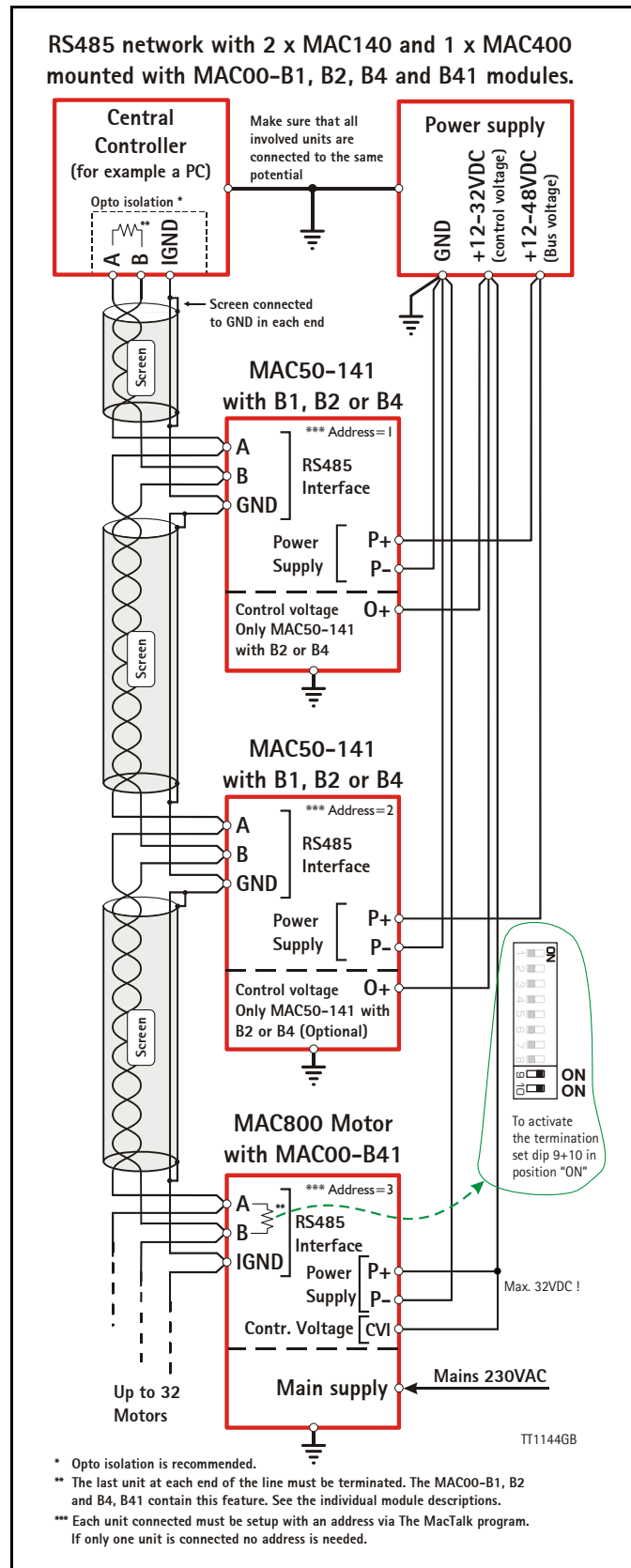

## 4.3 Expansion module MAC00-B41

Only MAC400 to 3000

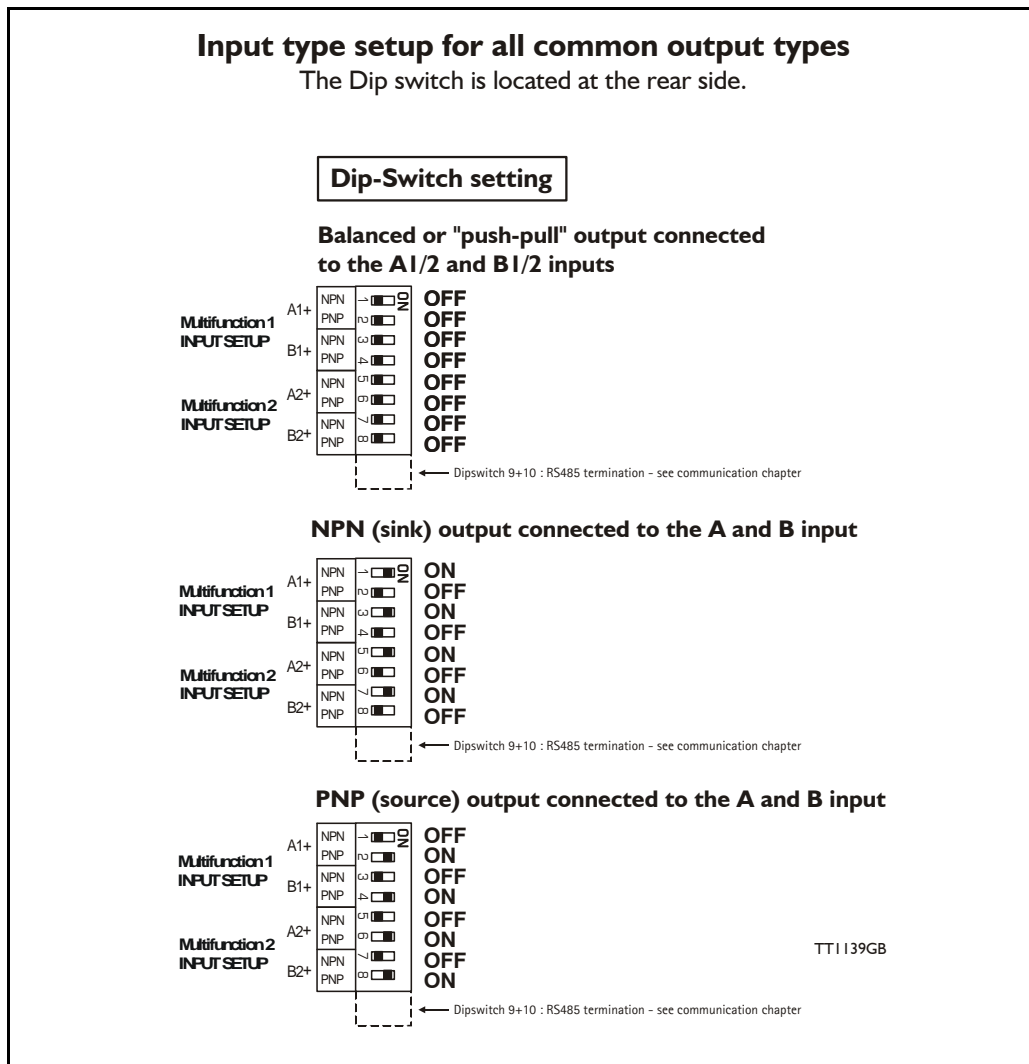

### 4.3.9 General description: "Multifunction I/O".

The function of the Multifunction I/O is equal to that of the basic motor with the exception that the B41 module include an overvoltage protection and a dip-switch to set up what kind of signal source feeds the input (if the Multifunction I/O is set up as inputs). The illustration above shows how to set up the Multifunction I/O terminals as balanced/push pull, NPN or PNP input. The illustrations below show examples of connections for each of these signal types.

## 4.3 Expansion module MAC00-B41

Only MAC400 to 3000

### 4.3.10 Connecting an NPN signal source to the Multifunction I/O

The drawing below shows how to connect an NPN source to the MAC00-B41 multifunction I/Os. The diagram shows the A channel. The B channel must be connected in the same manner. Ensure that the Ax- and Bx- terminals are unconnected in order to maintain proper function.

**Warning:** Voltages higher than 5V must under no circumstance be connected directly to the input since this will damage the input permanently.

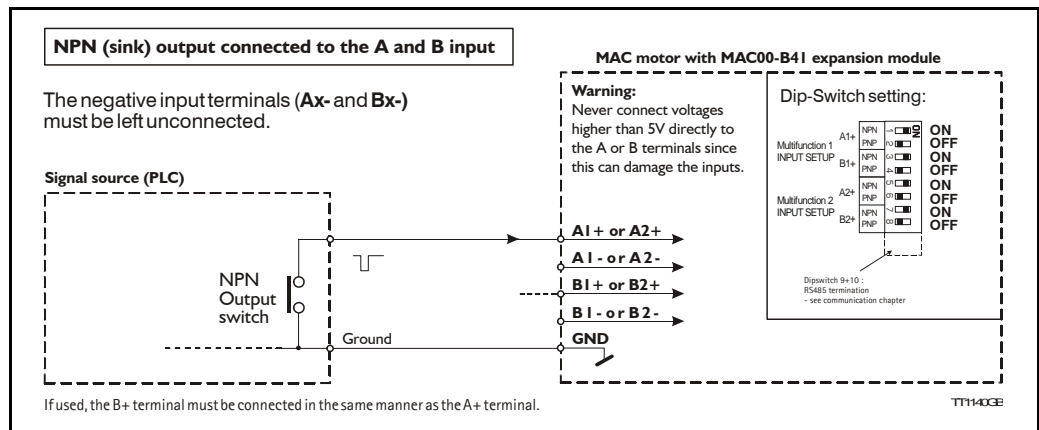

### 4.3.11 Connecting a PNP signal source to the Multifunction I/O

The drawing below shows how to connect a PNP source to the MAC00-B41 multifunction I/Os. The diagram shows the A channel. The B channel must be connected in the same manner.

Ensure that the Ax- and Bx- terminals are unconnected in order to maintain proper function.

**Warning:** Voltages higher than 5V must under no circumstance be connected directly to the input since this will damage the input permanently. Use a proper resistor as indicated in the table below.

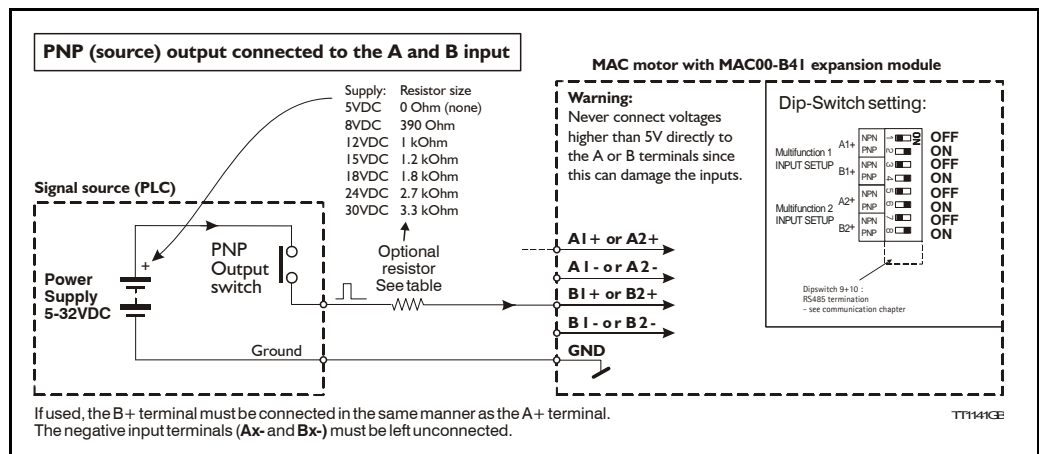

## 4.3 Expansion module MAC00-B41

Only MAC400 to 3000

### 4.3.12 Connecting a balanced/push-pull signal to the Multifunction I/O

The drawing below shows how to connect a balanced or push-pull signal source to the MAC00-B41 multifunction I/Os. Use twisted-pair cable for the balanced signals in order to ensure noise immunity.

**Note:** If inputs are used in pulse-direction format input A ( $A_{x+}/A_{x-}$ ) is pulse input and input B ( $B_{x+}/B_{x-}$ ) is direction input.

**Warning:** Voltages higher than 5V must under no circumstance be connected directly to the input since this will damage the input permanently. Use a proper resistor as indicated in the table below.

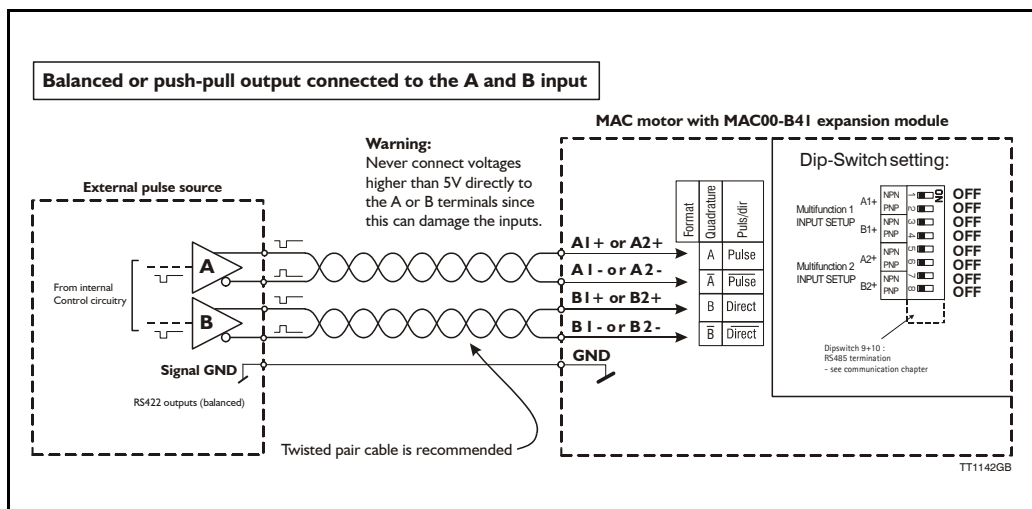



## 4.3 Expansion module MAC00-B41

Only MAC400 to 3000

### 4.3.13 Example - how to use gearmode with MAC00-B41.

The MAC00-B41 module offers a number of I/O possibilities that makes it very convenient to use in Electronic gear applications.

An external encoder with various output configurations can easily be connected to one of the multifunction I/O channels and also signals like Enable/disable motor can be established using one of I/O terminals (I/O1 to I/O6).

The following pages describe in details how to get the wiring sorted and also how to setup the motor in general.

The example will cover:

- Hardware : Connecting the encoder to the MAC00-B41
- Setting up relevant parameters for using gear mode
- Optionally setting up input 1 for enabling/disabling motor operation (enable input)
- Optionally setting up input 2 as a “coupling” input for enabling the motor to follow the encoder or staying stationary at 0 RPM (keeping the position).

#### Step 1

Start by connecting the encoder to the multifunction IO channel 1 according to the illustration below.

This example is showing an encoder equipped with a 24V PNP (source) output.

A serial resistor must be inserted since the IO channels at the MAC00-B41 is made for handling RS422 levels which means that no more than 5V must be applied. Higher levels will be destructive !.

Remember to set the internal dipswitch correctly in order to setup the module to handle a signal source with a PNP output.

See also *General description: “Multifunction I/O”*, page 142 for configuring the MAC00-B41 to other I/O's formats than the PNP used in this example.

Concerning the physical connector layout of the IO2 connector - please see *Expansion MAC00-B41 connector description*, page 149.

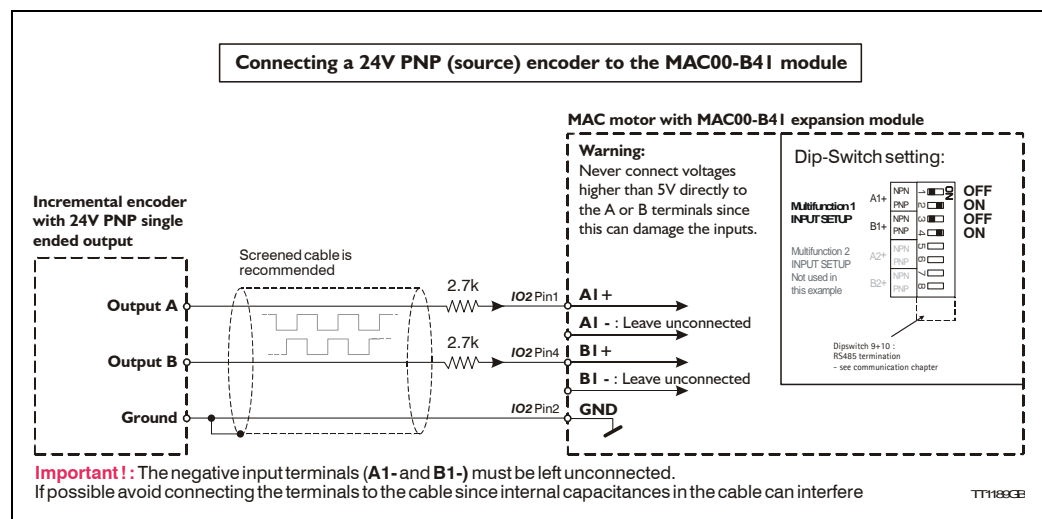

Continued at next page.

## 4.3 Expansion module MAC00-B41

Only MAC400 to 3000

### Step 2

Now the motor need to be setup in gear mode and the Multifunction I/O I must be setup as pulse input in order to accept the applied encoder signal.

This is done in the MacTalk windows software. See illustration below.

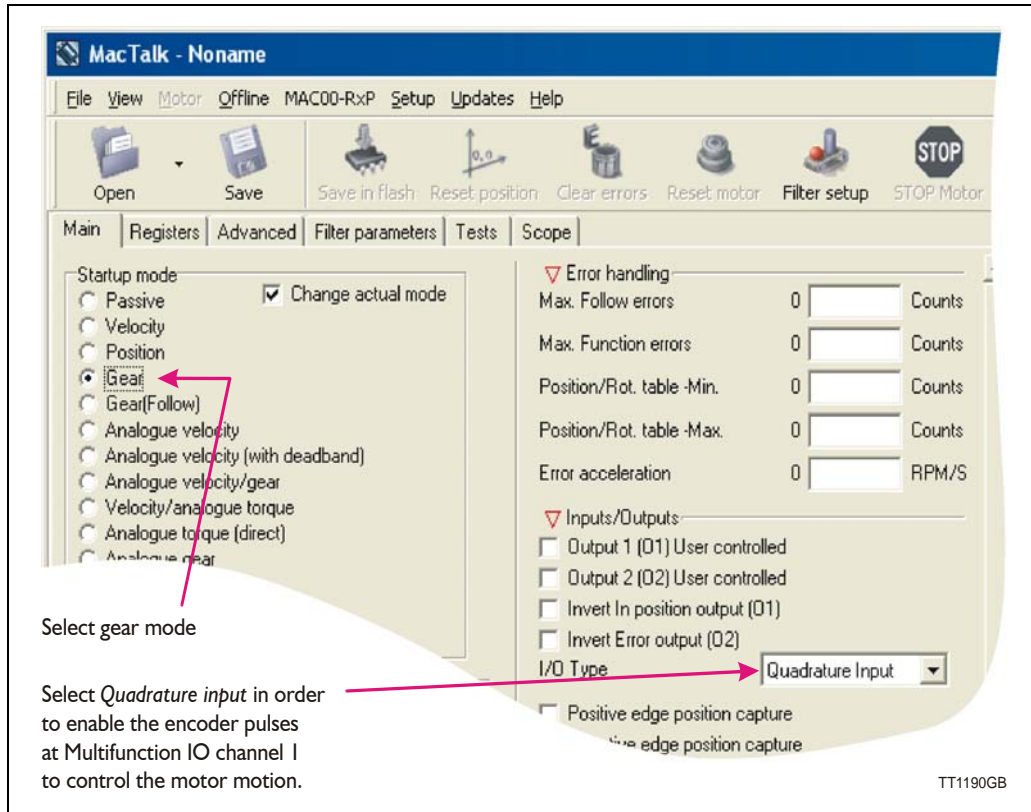

The desired gear ratio and other relevant motion parameters may also be necessary to setup. Please see the general gear mode description - *Gear Mode - overall description*, page 21

Now the motor should move accordingly to the connected external encoder using the Gear mode.

Continued at next page.

## 4.3 Expansion module MAC00-B41

Only MAC400 to 3000

### Step 3

Optionally an input can be used for enabling the motor in gear mode or making it passive (current less) which means that the shaft is not kept in position (the shaft is released). The illustration below shows how this setup can be done using the MacTalk program.

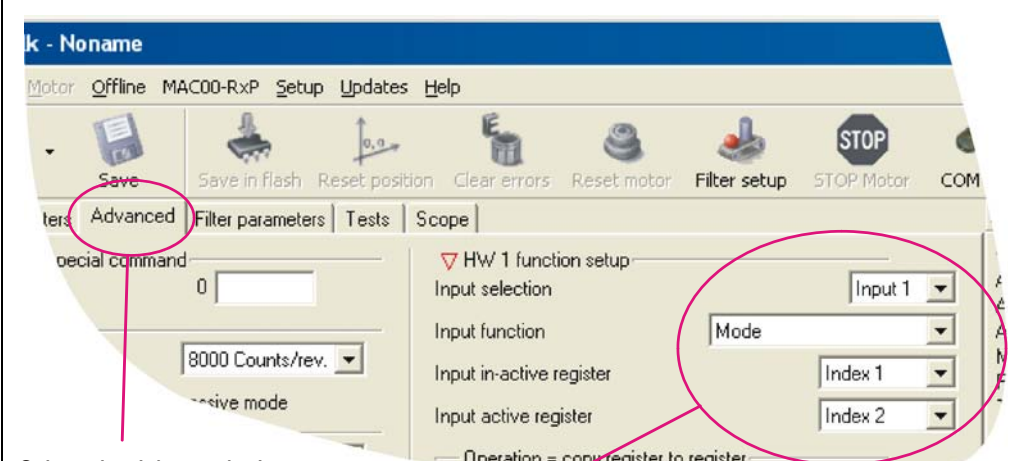

Select the *Advanced* tab

Setup as shown  
The result will be that input 1 (*IO1*) is used for selecting the motor mode (*Gear* or *Passive* mode). *Index 1* and *Index 2* is referring to the mode registers which are shown below.

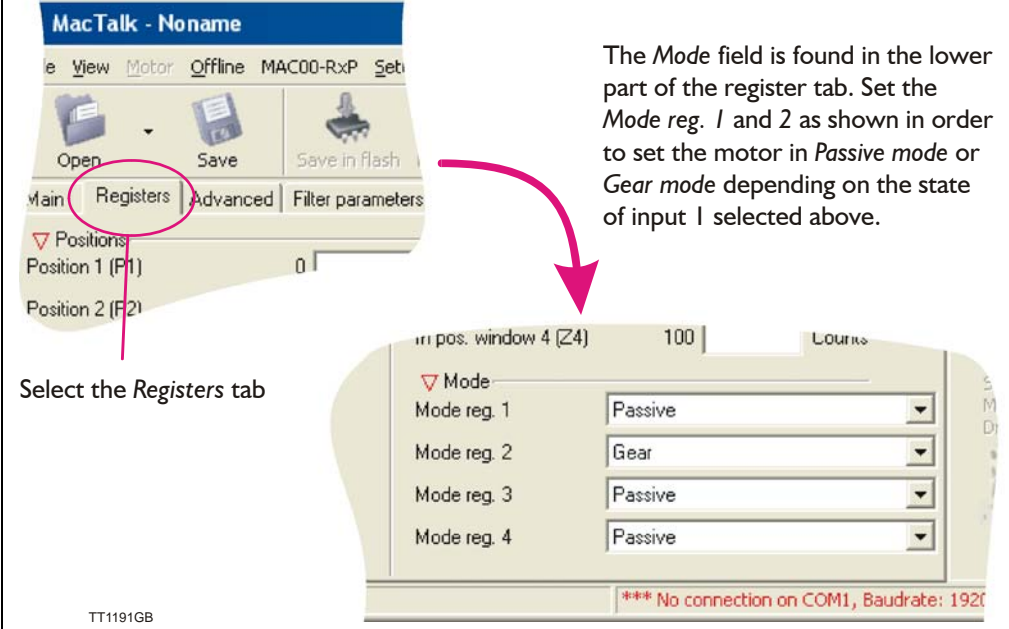

Select the *Registers* tab

The *Mode* field is found in the lower part of the register tab. Set the *Mode reg. 1* and *2* as shown in order to set the motor in *Passive mode* or *Gear mode* depending on the state of input 1 selected above.

Continued at next page

## 4.3 Expansion module MAC00-B41

Only MAC400 to 3000

### Step 4

Optionally an input can be used for enabling motor movement according to the external encoder when the input is active or decelerating the motor to a stationary position when the input is passive. Setup the motor according to the following illustration.

Select the *Advanced* tab

Setup as shown

The result will be that input 2 (IO2) is used for setting the motor speed to 0 RPM (stationary position) or any velocity above 0 RPM allowing the motor to move according to the external encoder.

Select the *Registers* tab

The *Velocity* field is found in the lower left part of the register tab. Set the *Velocity 1* to 0 and *Velocity 2* to the desired speed when input 2 is active. Note that the unit will toggle from RPM to cnt./smp. when activated by the mouse

Velocities	Value	Unit
Velocity 1 (V1)	0	RPM
Velocity 2 (V2)	3000	Cts/Smp
Velocity 3 (V3)	0	RPM
Velocity 4 (V4)	0	RPM

## 4.3 Expansion module MAC00-B41

Only MAC400 to 3000

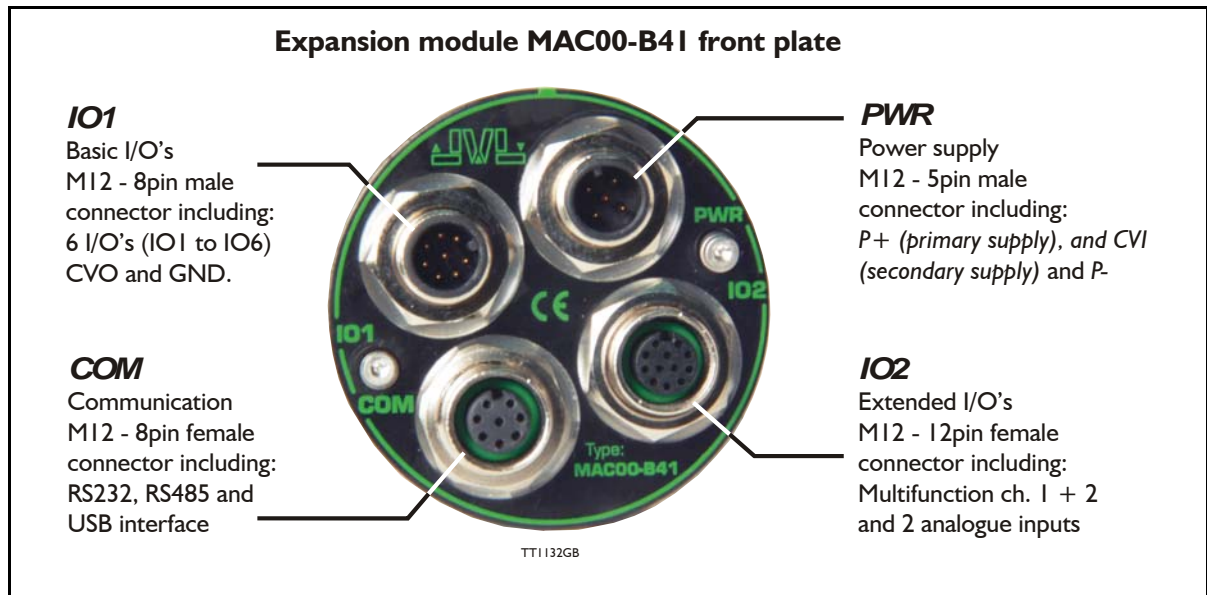

### 4.3.14 Expansion MAC00-B41 connector description

The MAC00-B41 offers IP65 protection and M12 connectors which makes it ideal for automation applications where no additional protection is desired. The M12 connectors offer solid mechanical protection and are easy to unplug compared to modules with cable glands or DSUB connectors.

The connector layout:

"PWR" - Power input. M12 - 5pin male connector				
Signal name	Description	Pin no.	JVL Cable W11000- M12F5T05N	Isolation group
P+	Main supply +12-48VDC. Connect with pin 2 *	1	Brown	1
P+	Main supply +12-48VDC. Connect with pin 1 *	2	White	1
P-	Main supply ground. Connect with pin 5 *	3	Blue	1
CVI	Control and user output supply +12-30VDC. <b>Connect MAXIMUM 30VDC to this terminal</b>	4	Black	1
P-	Main supply ground. Connect with pin 3 *	5	Grey	1

\* Note: P+ and P- are each available at 2 terminals. Make sure that both terminals are connected in order to split the supply current in 2 terminals and thereby avoid an overload of the connector.

(Continued next page)

## 4.3 Expansion module MAC00-B41

Only MAC400 to 3000

<b>"IO1" - Basic I/O's. M12 - 8pin male connector.</b>				
Signal name	Description	Pin no.	JVL Cable W1000-M12 F8T05N	Isolation group (See note)
I/O1	I/O channel 1 - Can be used as input or output	1	White	1
I/O2	I/O channel 2 - Can be used as input or output	2	Brown	1
I/O3	I/O channel 3 - Can be used as input or output	3	Green	1
I/O4	I/O channel 4 - Can be used as input or output	4	Yellow	1
I/O5	I/O channel 5 - Can be used as input or output	5	Grey	1
I/O6	I/O channel 6 - Can be used as input or output	6	Pink	1
CVO	Supply output. Connected internally to the <b>CVI</b> terminal in the PWR connector. <b>DO NOT connect &gt;30V to this terminal !</b>	7	Blue	1
GND	Ground intended to be used together with the other signals in this connector.	8	Red	1
<b>"COM" - Communication connector - M12 - 8pin female connector.</b>				
Signal name	Description	Pin no.	JVL Cable W1000-M12 M8T05N	Isolation group (See note)
USB: D-	USB interface. Negative data terminal	1	White	2
RS232: TX	RS232 interface. Transmit terminal Leave open if unused.	2	Brown	2
RS232: RX	RS232 interface. Receive terminal Leave open if unused.	3	Green	2
IGND	Isolated interface ground to be used together with the other signals in this connector,	4	Yellow	2
RS485: A-	RS485 interface. Leave open if unused	5	Grey	2
RS485: B+	RS485 interface. Leave open if unused	6	Pink	2
USB: D+	USB interface. Positive data terminal	7	Blue	2
USB: VBUS	USB interface. Supply input 5VDC nominal	8	Red	2
<b>"IO2" - I/O connector 2. M12 - 12pin female connector</b>				
Signal name	Description	Pin no.	JVL Cable W1100M12 M12T05N	Isolation group (see note)
A1+	Multifunction I/O1 terminal A1+	1	Brown	1
GND	Ground intended to be used together with the other signals in this connector	2	Blue	1
A1-	Multifunction I/O1 terminal A1-	3	White	1
B1+	Multifunction I/O1 terminal B1+	4	Green	1
A2+	Multifunction I/O2 terminal A2+	5	Pink	1
B1-	Multifunction I/O1 terminal B1-	6	Yellow	1
B2+	Multifunction I/O2 terminal B2+	7	Black	1
A2-	Multifunction I/O2 terminal A2-	8	Grey	1
5VO	5V out - max 100mA	9	Red	1
B2-	Multifunction I/O2 terminal B2-	10	Violet	1
AIN1	Analogue input1 $\pm 10V$ or used for <i>Zero search</i>	11	Grey/pink	1
AIN2	Analogue input2 $\pm 10V$	12	Red/blue	1



## 4.3 Expansion module MAC00-B41

Only MAC400 to 3000

### 4.3.15 Cables for the MAC00-B41

The following cables equipped with M12 connector can be supplied by JVL.

MAC00-B41 Connectors				Description	JVL Order no.	Picture
"IO1" 8pin male	"IO2" 12pin Female	"COM" 8pin Female	"PWR" 5pin Male			
		X		RS232 Interface cable. Connects directly from MAC00-B41 to a PC Length: 5m (197 inch)	RS232-M12-1-5-8	
		X		RS485 Interface cable. Connects directly from MAC00-B41 to a PC with a RS485 Com. port. Length: 5m (197 inch)	RS485-M12-1-5-8	
		X		USB Interface cable. Connects directly from MAC00-B41 to a PC with a USB Com. port. Length: 5m (197 inch)	USB-M12-1-5-8	(picture coming soon)
			X	Cable (Ø5.5mm) with M12 female 5-pin connector loose wire ends 0.35mm <sup>2</sup> (22AWG) and foil screen. Length: 5m (197 inch)	WI1000-M12F5T05N	
			X	Same as above but 20m (787 inch)	WI1000-M12F5T20N	
	X			Cable with M12 male 12 pin straight connector, loose wire ends.	WI1009-M12M12T05N	
	X			Same as above but 20m (787 inch)	WI1009-M12M12T20N	
X				Cable with M12 female 8pin straight connector, loose ends.	WI1000-M12F8T05N	
X				Same as above but 20m (787 inch)	WI1000-M12F8T20N	
		X		Cable with M12 male 8-pin connector loose wire ends 0.22mm <sup>2</sup> (24AWG) and screen. Length: 5m (197 inch)	WI1000-M12M8T05N	
		X		Same as above but 20m (787 inch)	WI1000-M12M8T20N	
<b>Protection caps. Optional if connector is not used to protect from dust / liquids.</b>						
	X	X		IP67 protection cap for M12 female connector.	WI1000-M12FCAP1	
X			X	IP67 protection cap for M12 male connector.	WI1000-M12MCAP1	

**Important:** Please note that the cables are a standard type. They are not recommended for use in cable chains or where the cable is repeatedly bent. If this is required, use a special robot cable (2D or 3D cable).

## 4.4 Expansion module MAC00-B42

Only MAC400 to 3000



### 4.4.1 Expansion module MAC00-B42 — overall description.

The MAC00-B42 is ment to be used as a small PLC with its 12 I/O terminals that can be read and written to from an user program in the basic motor.

The expansion module MAC00-B42can ONLY be mounted and used in following motors:

- MAC400
- MAC402
- MAC800 but only in newer versions with serial numbers >85000.
- MAC1500
- MAC3000

Please notice that the module is **NOT** recommended to be used in the **MAC050 to I41** motors since the following I/O terminals will not be active: IN1 to IN8 and O1 to O4. All other I/O terminals will be operative.

This module is among the simplest and lowest cost modules in the product range. The modules contain no intelligence (microprocessor) meaning that all functionality is controlled via the basic motor.

The MAC00-B42 expansion module offers an industrial interface (M12 connectors) and a number of feature enhancements, including:

- Full backward compatible with the MAC00-R4 module.
- Standard M12 connectors for optimum reliability.
- Full RS232 protocol support for use with standard serial cable.
- Full RS485 protocol support for multipoint communication up to 100m.
- 8 digital isolated inputs for 24V logic to be used with an user program in the motor.
- 4 digital isolated outputs for 24V logic to be used with an user program in the motor. Each output can supply up to 700 mA and is short circuit rated.
- LED indicators for I/O supply and main supply (control voltage).

#### Typical applications for these expansion modules are:

- Stand alone applications where the build in user program handles the local I/O's
- Replacement for pneumatic cylinders using the "Air Cylinder mode"
- Dispenser systems.
- Machine adjustment/setup by sending RS232 or RS485 commands.
- Standalone PLC with userprogram stored in the basic motor.



## 4.4 Expansion module MAC00-B42

Only MAC400 to 3000

### 4.4.2 Overall hardware description

All internal and external main connections can be seen in the illustration below.

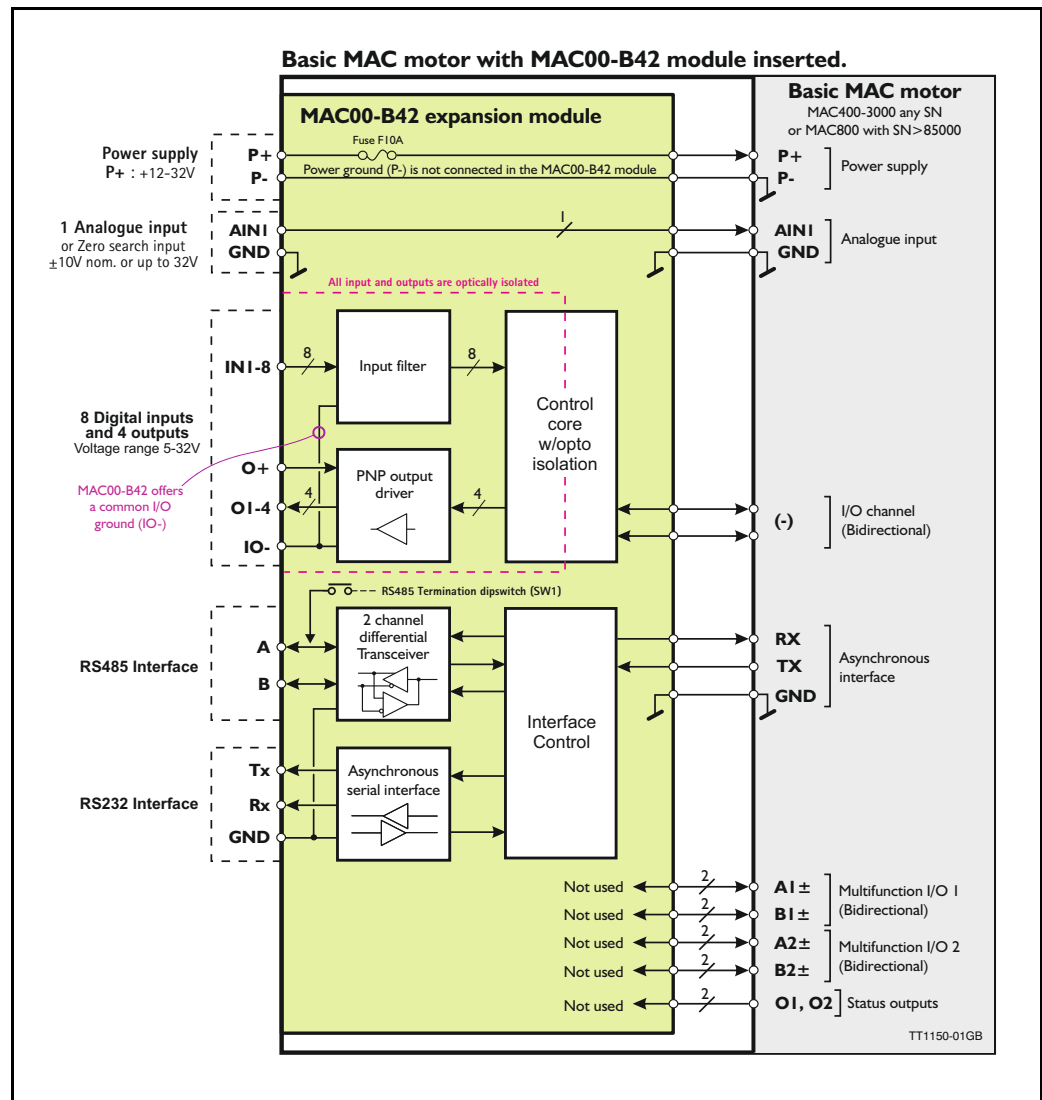

### 4.4.3 General hardware description

The MAC00-B42 module offers the following external connections.

- Power supply (P+/P-)**  
 These terminals are used for the main supply of the motor. A voltage between +12 and 32VDC.
- Analogue inputs (AINI)**  
 The analogue inputs are used either as analogue input or digital input. The primary analogue input is AINI. When used as analogue input, it can control velocity, torque or position depending on which mode is set for motor operation. When used for digital inputs, it can be used in position-related modes for the external zero-search sensor. Also in "Air Cylinder Mode" the analogue input is used as a trigger input. For a functional description, please refer to *Analogue input*, page 110.  
 (continued)

## 4.4 Expansion module MAC00-B42

Only MAC400 to 3000

- **Multifunction I/O 1 and 2 (AI ± ,BI ± , A2± and B2±)**  
(internal signals not supported externally)
- **Digital inputs (IN1, IN2, IN3, IN4, IN5, IN6, IO7, IO8, and IO-)**  
The inputs can be read from the serial interface (RS232 or RS485) or they can be operated from the user program stored in the motor.  
The source that feed the inputs must be a PNP/source type.  
The IO- terminal serves also as ground (common) for the user outputs.
- **Digital inputs (O1, O2, O3, O4, and IO-)**  
The outputs can be set from the serial interface (RS232 or RS485) or they can be operated from the user program stored in the motor.  
The IO- terminal serves also as ground (common) for the user inputs.
- **RS485 Interface (A-, B+ and GND)**  
Serial balanced interface for connection to a PC or a controller. The protocol is similar to the RS232 or USB interface, which means that all registers/parameters in the motor can be monitored or changed. The RS485 is recommended for longer distances or in noisy environments.
- **RS232 Interface (Rx, Tx and GND)**  
Serial unbalanced interface for connection to a PC or a controller. The protocol is similar to the RS485 interface, which means that all registers/parameters in the motor can be monitored or changed. RS232 is not recommended for long distances.

The MAC motor uses “binary” communication protocol which makes it possible to access all the internal registers. Please consult *MacTalk communication, page 378* for further details.

### 4.4.4 Building RxP programs

The MAC00-B42 module is primarily intended to be used as an I/O module which is equivalent to the MAC00-R4 module but with upgraded features.  
The overall software interface and programming is similar to the R4 module.  
Therefore the description of the commands and how to build a RxP program can be found on the pages *MAC00-RxP Main window, page 295* and *How to build a program, page 297*.

## 4.4 Expansion module MAC00-B42

Only MAC400 to 3000

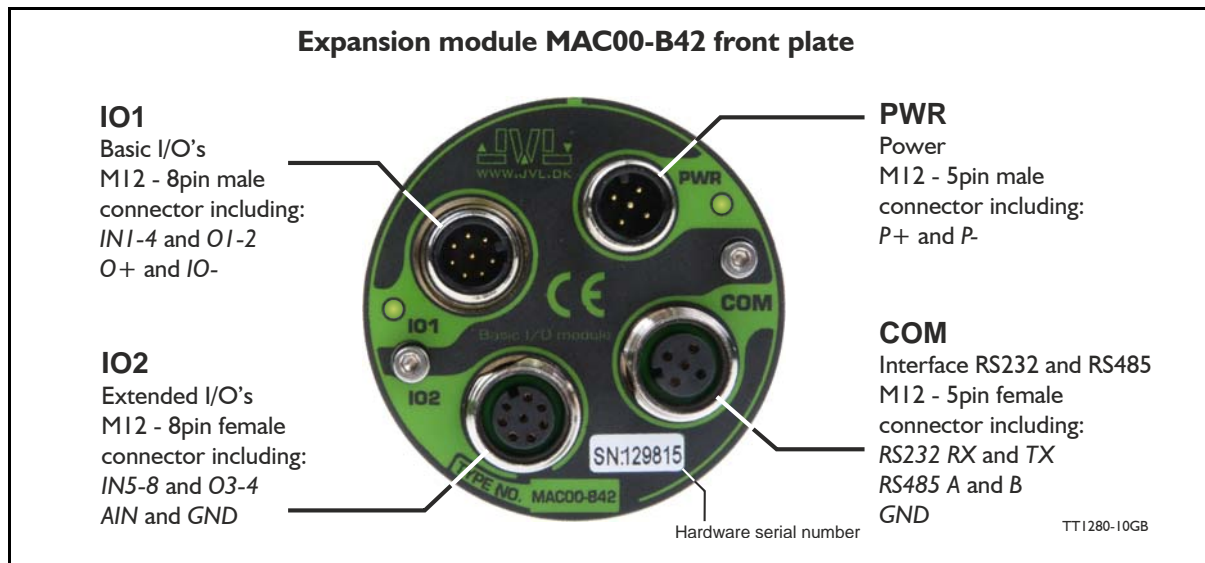

### 4.4.5 Expansion MAC00-B42 hardware description

The MAC00-B42 offers IP65 protection and M12 connectors which make it ideal for automation applications where no additional protection is desired. The M12 connectors offer solid mechanical protection and are easy to operate.

The connector layout:

"PWR" - Power input. M12 - 5-pin male connector				
Signal name	Description	Pin no.	JVL Cable W11000M12 F5T05N	Isolation group
P+	Main supply +12-48VDC. Connect with pin 2 *	1	Brown	1
P+	Main supply +12-48VDC. Connect with pin 1 *	2	White	1
P-	Main supply ground. Connect with pin 5 *	3	Blue	1
Unused	Future option	4	Black	-
P-	Main supply ground. Connect with pin 3 *	5	Grey	1
* Note: P+ and P- is each available at 2 terminals. Make sure that both terminals are connected in order to split the supply current between 2 terminals and thereby avoid an overload of the connector.				
"COM" - Interface RS232 and RS485. M12 - 5-pin female connector				
Signal name	Description	Pin no.	JVL Cable W11000M12 M5T05N	Isolation group
RS232 Rx	RS232 interface receive terminal. Leave open if unused	1	Brown	1
RS232 Tx	RS232 interface transmit terminal. Leave open if unused. - <b>Important, see note1:</b>	2	White	1
RS485 B+	RS485 interface terminal. Leave open if unused	3	Blue	1
RS485 A-	RS485 interface terminal. Leave open if unused	4	Black	1
GND	Interface ground (same as main ground).	5	Grey	1

Note 1: See also Dip switch for RS485 active termination, page 156

(Continued next page)

## 4.4 Expansion module MAC00-B42

Only MAC400 to 3000

(Continued from previous page)

<b>"IO1" - Basic I/O's. M12 - 8-pin male connector.</b>				
Signal name	Description	Pin no.	JVL Cable W11000-M12 F8T05N	Isolation group
IN1	Digital input 1	1	White	2
IN2	Digital input 2	2	Brown	2
IN3	Digital input 3	3	Green	2
IN4	Digital input 4	4	Yellow	2
O1	Digital output 1 - PNP output	5	Grey	2
O2	Digital output 2 - PNP output	6	Pink	2
O+	Output supply +12-32VDC. Used for O1-4. Not used/necessary for using IN1-8	7	Blue	2
IO-	I/O ground. Used for IN1-8 and O1-4.	8	Red	2
<b>"IO2" - Extended I/Os. M12 - 8-pin female connector.</b>				
Signal name	Description	Pin no.	JVL Cable W11000-M12 M8T05N	Isolation group
IN5	Digital input 5	1	White	2
IN6	Digital input 6	2	Brown	2
IN7	Digital input 7	3	Green	2
IN8	Digital input 8	4	Yellow	2
O3	Digital output 3 - PNP output	5	Grey	2
O4	Digital output 4 - PNP output	6	Pink	2
AIN1	Analogue input +/-10V (also used for <i>Zero search</i> sensor).	7	Blue	1
GND	Ground for AIN. This ground is shared with the main ground	8	Red	1
<b>Cable Screen</b>				
Some standard cables with M12 connectors offer a screen around the cable. This screen on some cables is fitted to the outer metal at the M12 connector. When fitted to the MAC00-B42 module, this means that the screen will have contact with the complete motor housing and thereby also the power ground (main ground).				
<b>Isolation groups</b>				
The MAC00-B42 offers optical isolation at the digital inputs and outputs (IN1-8 and O1-4). The table above shows a number for each pin. This number refers to the isolation group to which the terminal is connected. Isolation group 1 means that the terminal refers to the main ground. Isolation group 2 means that the terminal refers to the I/O ground (IO-).				

### 4.4.6 Dip switch for RS485 active termination

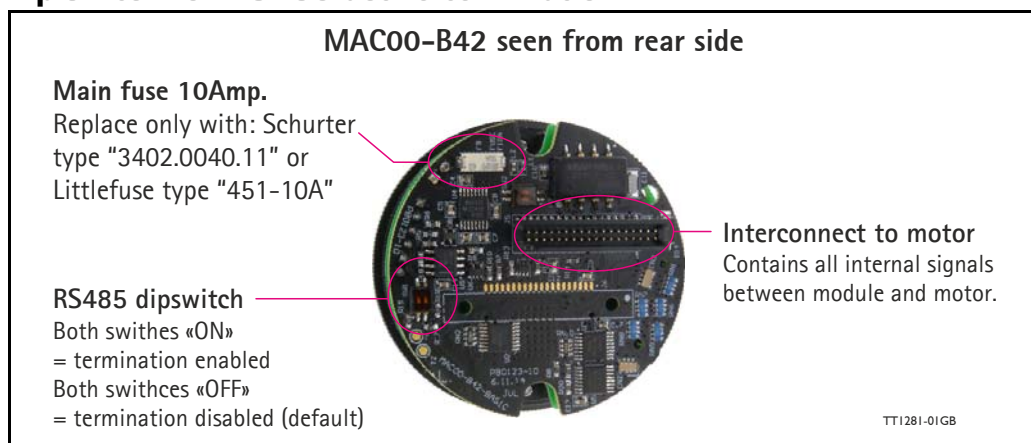







If the MAC motor is connected to other units at a RS485 line the last unit in each end of the line must have activated the termination dip switches.

## 4.4 Expansion module MAC00-B42

Only MAC400 to 3000

### 4.4.7 Cables for the MAC00-B42

The following cables equipped with M12 connector can be supplied by JVL.

MAC00-B42 Connectors				Description	JVL Order no.	Photo
"IO1" 8-pin Male	"IO2" 8-pin Female	"COM" 5-pin Female	"PWR" 5-pin Male			
		X		RS232 Interface cable. Connects directly from MAC00-B42 to PC Length: 5m (197 inch)	RS232-M12-1-5-5	
			X	Cable (Ø5.5mm) with M12 female 5 pin connector loose ends 0.35mm <sup>2</sup> (22AWG) and screen. Length: 5m (197 inch)	WI1000-M12F5T05N	
			X	Same as above but 20m (787 inch)	WI1000-M12F5T20N	
		X		Cable with M12 male 5-pin connector loose wire ends 0.35mm <sup>2</sup> (22AWG) and screen. Length: 5m (197 inch).	WI1000-M12M5T05N See also type: RS232-M12-1-5-5	
		X		Same as above but 20m (787 inch)	WI1000-M12M5T20N	
X				Cable with M12 female 8-pin connector loose wire ends 0.22mm <sup>2</sup> (24AWG) and screen. Length: 5m (197 inch)	WI1000-M12F8T05N	
X				Same as above but 20m (787 inch)	WI1000-M12F8T20N	
	X			Cable with M12 male 8-pin connector loose wire ends 0.22mm <sup>2</sup> (24AWG) and screen. Length: 5m (197 inch)	WI1000-M12M8T05N	
	X			Same as above but 20m (787 inch)	WI1000-M12M8T20N	
<b>Protection caps. Optional if connector is not used, to protect from dust / liquids.</b>						
	X	X		IP67 protection cap for M12 female connector.	WI1000-M12FCAP1	
X			X	IP67 protection cap for M12 male connector.	WI1000-M12MCAP1	

**Important:** Please note that the cables are a standard type. They are not recommended for use in cable chains or where the cable is repeatedly bent. If this is required, use a special robot cable (2D or 3D cable).

See also *Accessories*, page 415

## 4.5 Expansion module MAC00-Exx4

---

### 4.5.1 Industrial Ethernet modules

The documentation for the industrial Ethernet modules is very extensive and has therefore been placed as a separate user manual LB0056-xx.

The complete user manual can be downloaded using this link : [www.jvl.dk](http://www.jvl.dk)

Following Ethernet modules are available : EthernetIP, ProfiNET, EtherCAT, Powerlink and soon available Sercos III.

**MAC800 users - Important:** Please notice that MAC800 motors with a serial number lower than 85000 do NOT support the Ethernet modules.

## 4.6 Expansion Mod. MAC00-FC2/FC4/FC4I

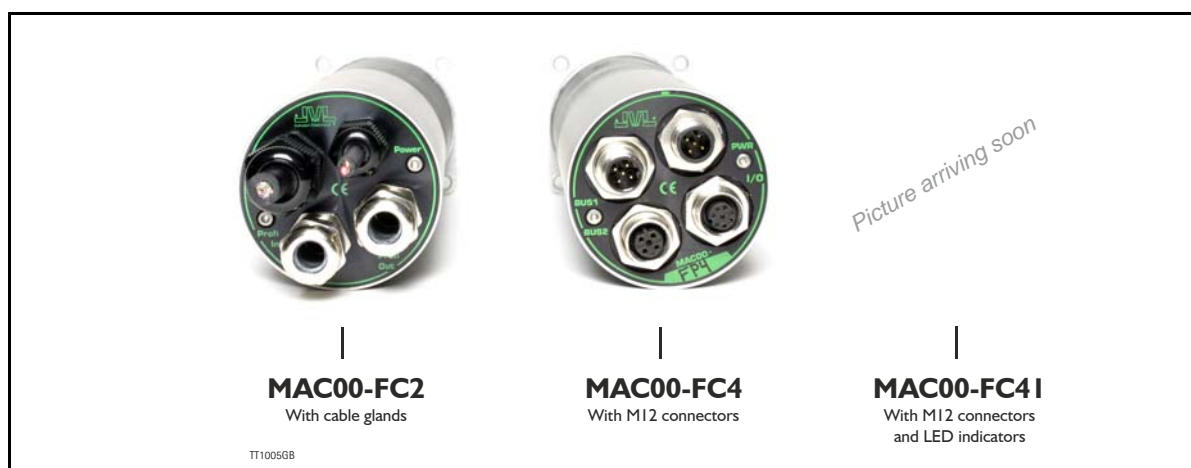

### 4.6.1 Introduction to this section

This chapter describes JVL's expansion modules MAC00-FC2, FC4 and FC4I, which are used to build in a MAC motor in order to connect the motor to a CANopen® network.

This section covers:

- General introduction, a section with general information about CANopen®, from section 4.6.1 to section 4.6.6
- Setting up the Baud-rate, node-id and termination of the CAN bus. Covers also the wiring of the CAN bus. From section 4.6.7 to section 4.6.15
- How to use CanOpenExplorer and Mac-Talk debug window section 4.6.16 to section 4.6.17.
- Survey over Communication specific objects and manufacturer specific objects in the DS301 standard. Communication objects are the general information about the settings in the module, where the Manufacturer specific object are the settings of input/output and the motor parameters. This section also covers the settings of the transmit and receive PDOs in the module. From section 4.6.18 to section 4.6.44.
- Survey over objects which are used in connection with the DSP-402 standard. From section 4.6.45 to section 4.6.52.
- How to connect and cables for the modules section 4.6.60 to section 4.6.66
- Section with more detail explanations to the CANopen® theory, particularly DS-301. From section section 4.6.53 to section 4.6.59.

## 4.6 Expansion Mod. MAC00-FC2/FC4/FC41

### 4.6.2 CANopen® Introduction

The MAC00-FCxx expansion modules are CANopen® slaves. With these modules, all of the registers in the MAC motor can be accessed over a CANopen® network. The modules implement an object dictionary that follows the CiA® DS-301 standard. The modules contain a number of statically mapped PDOs that can be used to access the most common registers. The modules also support the DSP-402 standard from CiA®.

The expansion modules can be mounted in all the standard MAC motors MAC50, MAC95, MAC140, MAC141, MAC400, MAC402, MAC800, MAC1500 and MAC3000.

Both modules offer the same functionality but with the following hardware differences:

Type	Protection class	LED Indicators	Connectors		
			I/O and interface	Power supply	Bus interface
MAC00-FC2	IP67/IP65*	No	Cable glands (Mini crimp connectors internally)	Cable glands (Screw terminals internally)	Cable glands x 2 (Screw terminals internally)
MAC00-FC4	IP67/IP65*	No	Industrial M12	Industrial M12	Industrial M12 (x2)
MAC00-FC41	IP67/IP65*	Yes	Industrial M12	Industrial M12	Industrial M12 (x2)

\* Note: IP65 on MAC400-800

The MAC00-FC2 module can be delivered with cable in selected lengths. Cables with M12 connectors can also be supplied for the MAC00-FC4 and MAC00FC41 module.

The MAC00-FCxx expansion modules is designed to be used on a CANbus, CANopen® DS-301 and CANopen® DSP-402, do not use the module together with CANKingdom or DeviceNet.

### 4.6.3 CiA® membership

CiA® (CAN in Automation) is a non-profit society, the object of the society is to promote CAN (Controller-Area-Network) image and to provide a path for future developments of the CAN protocol. CiA® specifications cover physical layer definitions as well as application layer and device profile descriptions.

In order to receive the CANopen® standard, is it necessary to obtain a membership of the society. The fee for the membership is depending on how many employees you company has. A membership runs from January 1<sup>st</sup> until December 31<sup>st</sup> every year. Your membership is renewed automatically unless you cancel it in writing by the end of a calendar year. Companies applying for membership after July 1<sup>st</sup> pay just 50 % of the membership for that year.

On [www.can-cia.org/cia/application.html](http://www.can-cia.org/cia/application.html) can you download a application file in PDF format and fill it in.

When you have received you license from CiA®, you have to be aware that the standards will be sent on a CD. All of the CiA specifications can be ordered on this web-page:

<http://www.can-cia.org/standardization/specifications/>



## 4.6 Expansion Mod. MAC00-FC2/FC4/FC41

### 4.6.4 CANopen® network

The CAN bus, is a serial bus with multi-master capabilities where different products from different manufacturers can communicate with each other. This could be devices as PLCs, motors, sensors and actuators. Message types have higher priority and are sent first, for time critical applications. New devices can easily be integrated on a existing bus, without the need to reconfigure the entire network. The devices are connected through a 2 wire bus cable, and data is transmitted serially.

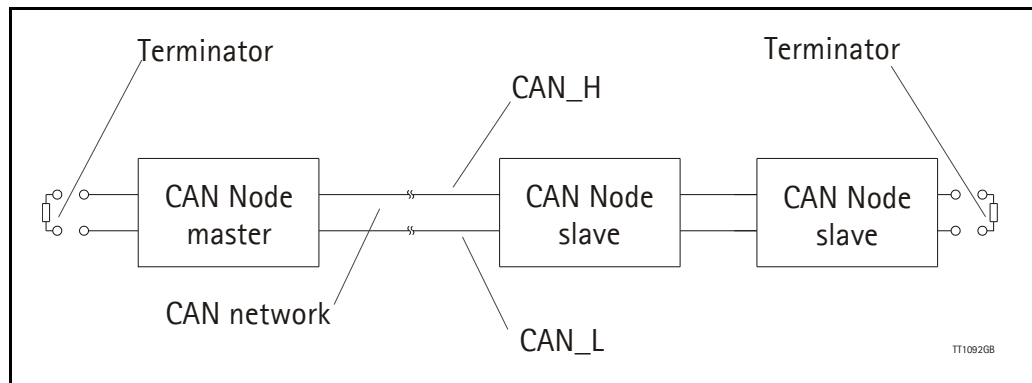

### 4.6.5 CANopen®, general information

CANopen® is a CAN-based higher level protocol. The purpose of CANopen® is to give an under stable and unique behaviour on the CAN network. The CAN network is the hardware level of the system, and CANopen® is the software level. CANopen® is based on the communication profile described in CiA® DS-301, and it specifies all of the basic communication mechanisms.

CiA® DS-301 contains message types on the lowest software level. The DSP-402 CANopen® standard defines the device profile and the functional behaviour for servo drive controllers, frequency inverters and stepper motor. The DSP-402 is a higher software level, and it use the DS-301 communication, but is making the device independent of the manufacturer. If the devices using only the DSP- 402 it is possible that some general data can be lost.

The CAN bus with real-time capabilities work in accordance with the ISO 11898 standard. The major performance features and characteristic of the CAN protocol are described below:

#### Message-oriented protocol:

The CAN protocol does not exchange data by addressing the recipient of the message, but rather mark each transmitted message with a message identifier. All nodes in the network check the identifier when they receive a message to see whether it is relevant for them, messages can there for, be accepted by none, one, several or all participants.

#### Prioritisation of messages:

As the identifier in a message also determines its priority for accessing the bus, it is possible to specify a correspondingly rapid bus access for messages according to their importance. Especially important messages can thus gain access to the bus without a prolonged wait-time, regardless of the loading on the bus at that moment.

This characteristic mean that especially important messages are transmitted with priority even in exceptional situations, thereby ensuring proper functioning of a system even during phases of restricted transmission capacity.

## 4.6 Expansion Mod. MAC00-FC2/FC4/FC41

### Multi-Master capability:

Bus access rights are not issued by a mean-level control unit (bus master) per network. Each participant can rather start to send a message with equal rights as soon as the bus has become free. If several participants access the bus at the same time, an arbitration process allocates each participant the bus access right in line with the priority of the message they want to send at that particular moment. Each participant can therefore communicate directly with every other participant. As the transmission of a message can be initiated by the message source itself, then in the case of event-controlled transmission of messages, the bus is only occupied when a new message is on-hand.

### No-loss bus arbitration:

As the bus is accessed at random under the CAN protocol, it is possible that several participants want to occupy the bus at the same time. In other random bus access routines, this causes the destruction of the suppressed messages. In order to solve such a bus access conflict, a repeated occupation of the bus is required using an appropriate triggering strategy. The CAN protocol therefore deploys a routine to ensure that the message with the highest priority at any given time is sent without any destruction of message contents.

### Short block length:

The maximum data length of a CAN message is limited to 8 bytes. This data length is usually sufficient to transmit the information occurring in the lowest field area in a CAN message.

### 4.6.6 Header

A CAN message transmits the communications object and a variety of management and control information. The management and control information bits are used to ensure error free data transmission, and are automatically removed from the received message and inserted before a message is sent. A simplified CANopen® message could be as the figure below:

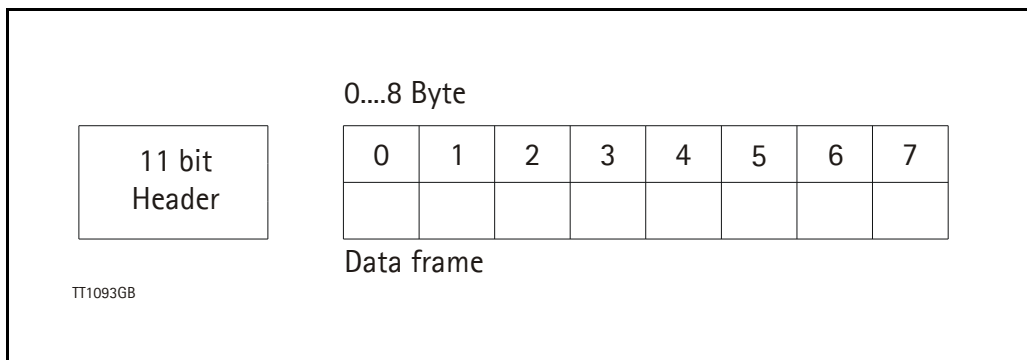

The two bit fields “Header” and “Data” form the simplified CANopen® message. The 11-bit Header are also designated as the identifier or as the COB-ID (Communication Object identifier).

JVL uses 11-bit format type CAN A, but not 29-bit format type CAN B.

The COB-ID carries out two task for the controller communications object.

- Bus arbitration: Specification of transmission priorities.
- Identification of communications objects.

The COB-ID comprising two sections:

- Function code, 4 bit in size (0...15d)
- Node address (Node ID), 7 bit in size (0...127d). See section 4.3.12.

## 4.6 Expansion Mod. MAC00-FC2/FC4/FC41

The function code classifies the communications objects, and controls the transmission priorities. Objects with a small function code are transmitted with high priority. For example, in the case of a simultaneous bus access an object with the function code “1” is sent before an object with the function code “3”.

### Node address:

Every device is configured before network operation with a unique 7-bit long node address between 1 and 127. The device address “0” is reserved for broadcast transmissions, in which messages are sent simultaneously to all devices.

PDO, SDO, EMCY, NMT and heartbeat are using the header frame for communication on the CANopen® bus.

### 4.6.7 Connecting MAC00-FC2/FC4/FC41 to the CAN bus

Before you connect the MAC00-FC2/FC4/FC41 to the CAN bus shall the Baud-rate, the Node-ID and the termination must be selected.

On the serial bus it is possible to have a transmission speed (Baud-rate) of max. 1000 Kbit/s and a min. of 10 Kbit/s. The Baud-rate depends on the cable length, and the wires cross-section, the table below have some recommendations for networks with less than 64 nodes. Recommended bus cable cross-section are according to CiA®:

Bus Distance (m)	Cross-section (mm <sup>2</sup> )	Terminator (ohm)	Baud-rate (Kbit/s)
25	0.25-0.34	120	1000
100	0.34-0.6	150-300	500
250	0.34-0.6	150-300	250
500	0.5-0.6	150-300	125
500	0.5-0.6	150-300	100
1000	0.75-0.8	150-300	50

The bus wires may be routed in parallel, twisted and/or shielded, depending on EMC requirements. The layout of the wiring should be as close as possible to a single line structure, in order to minimize reflections. The cable stubs for connection of the bus node shall be as short as possible, especially at high bit rates. The cable shielding in the house shall have a large contact area. For a drop cable a wire cross-section of 0.25 to 0.34 mm<sup>2</sup> would be an appropriate choice in many cases. In section 4.3.46 of this chapter there is an overview showing various JVL standard cables. All the JVL cables are twisted and shielded.

For bus lengths greater than 1 km, a bridge or repeater device is recommended. galvanic isolation between the bus nodes is optional. The MAC00-FCxx modules has a galvanic isolation integrated to obtain best possible immunity against noise and differences in the voltage potential between the nodes.

## 4.6 Expansion Mod. MAC00-FC2/FC4/FC41

### 4.6.8 Necessary accessories to MAC-FC2/FC4/FC41:

On our web page [www.jvl.dk](http://www.jvl.dk) you can, under the downloads menu find the EDS file for the modules, in the menu Field bus Interface Specifications Files. EDS means Electronic Data Sheet. This file contains the information about the module settings, that is required to configure the setup and program in the master.

The module is a slave module on the CAN-bus, the master can be for example a PLC or a PC. If you are using a PLC as master, then make sure that it is provided with a CAN-open® communications module, and that the correct programming tools are available. For getting support to the PLC master, it is more rewarding to use the PLC vendor.

If you are using a PC as master JVL have some tools that can help you when you are installing and using the MAC00-FC2/FC4/FC41.

The latest firmware for the MAC00-FC2/FC4/FC41 module is in the menu downloads/firmware. In the menu for programs you can find the program CanOpen Explorer, this is a free-ware program.

The CanOpen Explorer program can be used to load the EDS file, and operate with the motor. The CanOpen Explorer program shall use a special dongle for communication with the PC, see section 4.3.17 for further information about the dongle. The PC has to be provided with a CANopen® communications module. In section 4.3.46 there is a survey of cables JVL can supply, for the CAN-bus.

The MacTalk program can be used to monitor various operations and make the initial set up on the motor see section 1.1 for setting up the MAC motor. In the menu for programs you can find the program MacTalk, but be aware that this is not a free-ware program. Please contact your JVL representative for further information.

### 4.6.9 EDS (Electronic data Sheet)

In order to give the user of CANopen® more support, are the device description available in a standardised way, and it gives the opportunity to create standardised tools for configuration of CANopen® devices, designing networks with CANopen® devices and managing project information on different platforms. The EDS file are ASCII-coded.

### 4.6.10 Preparing the hardware

To make the selection of the Baud-rate, Node-ID and Line termination on the MAC00-FC2/FC4/FC41 module is it necessary to dismantle the module from the motor, and select it via the two Dip switches on the rear side of the module, notice that MAC00-FC4 include one more Dip switch, see section 4.6.12:

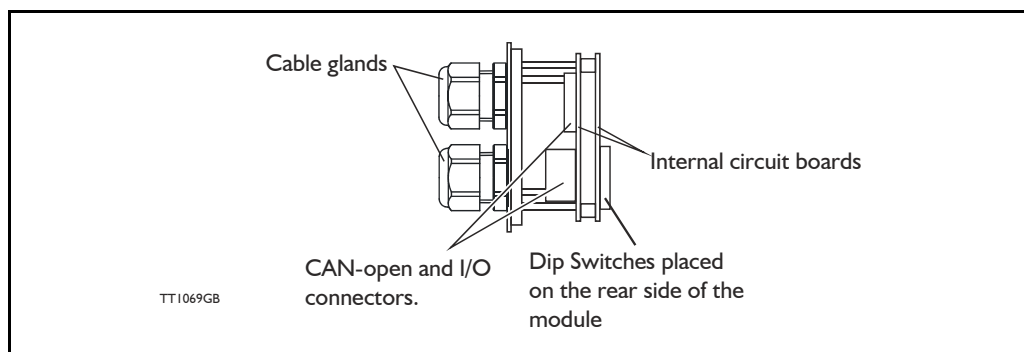

## 4.6 Expansion Mod. MAC00-FC2/FC4/FC41

### 4.6.11 Baud-rate:

The Baud-rate can be set according to the following table, and is selected on the Dip switch SW1 dip 8-10, as shown on the figure below:

Baud-rate	Dip Switch no. (SW1)		
	10	9	8
1000 kbit	OFF	OFF	OFF
500 kbit (factory default)	OFF	OFF	ON
250 kbit	OFF	ON	OFF
125 kbit	OFF	ON	ON
100 kbit	ON	OFF	OFF
50 kbit	ON	OFF	ON
20 kbit	ON	ON	OFF
10 kbit	ON	ON	ON

The factory default settings sets the module to have a Baud-rate of 500 kbit.

The Baud-rate is the external communication speed. Please notice that internal execution time can be the main limitation meaning that data will be received at the selected Baud-rate but not necessarily executed at the same time.

The Baud-rate setting can only be done in the hardware, it is not possible to set this by using the MacTalk software.

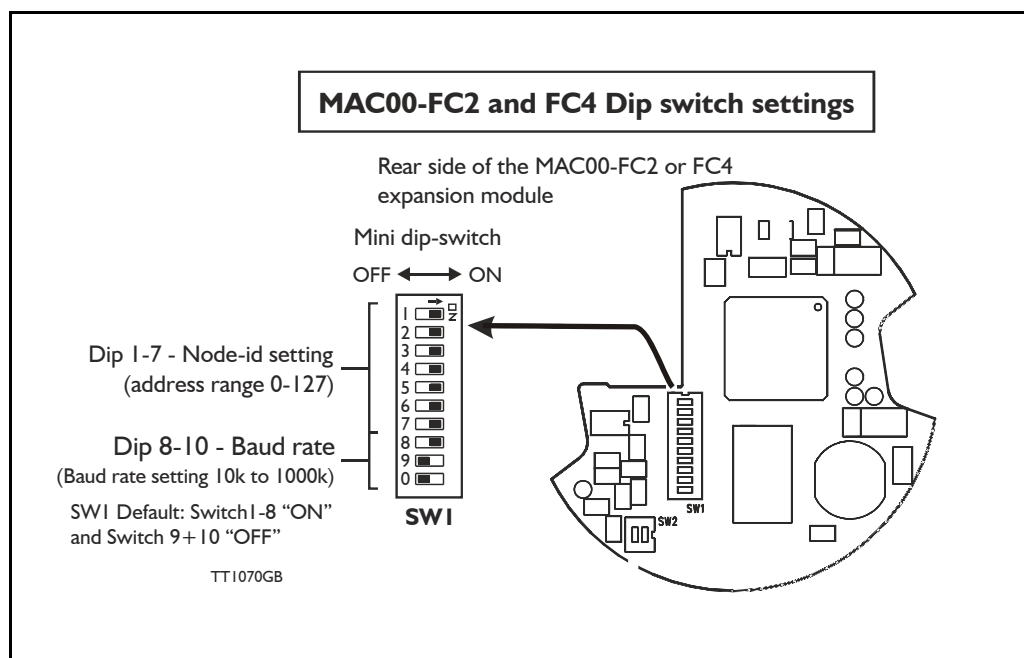

## 4.6 Expansion Mod. MAC00-FC2/FC4/FC41

### 4.6.12 Node-ID:

The node-ID can be selected on the Dip switch SW1 Dip 1-7. The address can be set according to the following table:

If the node-id is set to 127, the node address will be set to the same as the motor address (can be defined in MacTalk), which is the factory setting for the modules.

Node-id	Dip Switch no. (SW1)							Node-id	Dip Switch no. (SW1)						
	7	6	5	4	3	2	1		7	6	5	4	3	2	1
0	Reserved (illegal setting)							31	OFF	OFF	ON	ON	ON	ON	ON
1	OFF	OFF	OFF	OFF	OFF	OFF	ON	32	OFF	ON	OFF	OFF	OFF	OFF	OFF
2	OFF	OFF	OFF	OFF	OFF	ON	OFF	33	OFF	ON	OFF	OFF	OFF	OFF	ON
3	OFF	OFF	OFF	OFF	OFF	ON	ON	34	OFF	ON	OFF	OFF	OFF	ON	OFF
4	OFF	OFF	OFF	OFF	ON	OFF	OFF	35	OFF	ON	OFF	OFF	OFF	ON	ON
5	OFF	OFF	OFF	OFF	ON	OFF	ON	36	OFF	ON	OFF	OFF	ON	OFF	OFF
6	OFF	OFF	OFF	OFF	ON	ON	OFF	37	OFF	ON	OFF	OFF	ON	OFF	ON
7	OFF	OFF	OFF	OFF	ON	ON	ON	38	OFF	ON	OFF	OFF	ON	ON	OFF
8	OFF	OFF	OFF	ON	OFF	OFF	OFF	39	OFF	ON	OFF	OFF	ON	ON	ON
9	OFF	OFF	OFF	ON	OFF	OFF	ON	40	OFF	ON	OFF	ON	OFF	OFF	OFF
10	OFF	OFF	OFF	ON	OFF	ON	OFF	41	OFF	ON	OFF	ON	OFF	OFF	ON
11	OFF	OFF	OFF	ON	OFF	ON	ON	42	OFF	ON	OFF	ON	OFF	ON	OFF
12	OFF	OFF	OFF	ON	ON	OFF	OFF	43	OFF	ON	OFF	ON	OFF	ON	ON
13	OFF	OFF	OFF	ON	ON	OFF	ON	44	OFF	ON	OFF	ON	ON	OFF	OFF
14	OFF	OFF	OFF	ON	ON	ON	OFF	45	OFF	ON	OFF	ON	ON	OFF	ON
15	OFF	OFF	OFF	ON	ON	ON	ON	46	OFF	ON	OFF	ON	ON	ON	OFF
16	OFF	OFF	ON	OFF	OFF	OFF	OFF	47	OFF	ON	OFF	ON	ON	ON	ON
17	OFF	OFF	ON	OFF	OFF	OFF	ON	48	OFF	ON	ON	OFF	OFF	OFF	OFF
18	OFF	OFF	ON	OFF	OFF	ON	OFF	49	OFF	ON	ON	OFF	OFF	OFF	ON
19	OFF	OFF	ON	OFF	OFF	ON	ON	50	OFF	ON	ON	OFF	OFF	ON	OFF
20	OFF	OFF	ON	OFF	ON	OFF	OFF	51	OFF	ON	ON	OFF	OFF	ON	ON
21	OFF	OFF	ON	OFF	ON	OFF	ON	52	OFF	ON	ON	OFF	ON	OFF	OFF
22	OFF	OFF	ON	OFF	ON	ON	OFF	53	OFF	ON	ON	OFF	ON	OFF	ON
23	OFF	OFF	ON	OFF	ON	ON	ON	54	OFF	ON	ON	OFF	ON	ON	OFF
24	OFF	OFF	ON	ON	OFF	OFF	OFF	55	OFF	ON	ON	OFF	ON	ON	ON
25	OFF	OFF	ON	ON	OFF	OFF	ON	56	OFF	ON	ON	ON	OFF	OFF	OFF
26	OFF	OFF	ON	ON	OFF	ON	OFF	57	OFF	ON	ON	ON	OFF	OFF	ON
27	OFF	OFF	ON	ON	OFF	ON	ON	58	OFF	ON	ON	ON	OFF	ON	OFF
28	OFF	OFF	ON	ON	ON	OFF	OFF	59	OFF	ON	ON	ON	OFF	ON	ON
29	OFF	OFF	ON	ON	ON	OFF	ON	60	OFF	ON	ON	ON	ON	OFF	OFF
30	OFF	OFF	ON	ON	ON	ON	OFF	61	OFF	ON	ON	ON	ON	OFF	ON

Table continued on next page

## 4.6 Expansion Mod. MAC00-FC2/FC4/FC41

Address table continued from previous page

Node-id	Dip Switch no. (SW1)							Node-id	Dip Switch no. (SW1)						
	7	6	5	4	3	2	1		7	6	5	4	3	2	1
62	OFF	ON	ON	ON	ON	ON	OFF	95	ON	OFF	ON	ON	ON	ON	ON
63	OFF	ON	ON	ON	ON	ON	ON	96	ON	ON	OFF	OFF	OFF	OFF	OFF
64	ON	OFF	OFF	OFF	OFF	OFF	OFF	97	ON	ON	OFF	OFF	OFF	OFF	ON
65	ON	OFF	OFF	OFF	OFF	OFF	ON	98	ON	ON	OFF	OFF	OFF	ON	OFF
66	ON	OFF	OFF	OFF	OFF	ON	OFF	99	ON	ON	OFF	OFF	OFF	ON	ON
67	ON	OFF	OFF	OFF	OFF	ON	ON	100	ON	ON	OFF	OFF	ON	OFF	OFF
68	ON	OFF	OFF	OFF	ON	OFF	OFF	101	ON	ON	OFF	OFF	ON	OFF	ON
69	ON	OFF	OFF	OFF	ON	OFF	ON	102	ON	ON	OFF	OFF	ON	ON	OFF
70	ON	OFF	OFF	OFF	ON	ON	OFF	103	ON	ON	OFF	OFF	ON	ON	ON
71	ON	OFF	OFF	OFF	ON	ON	ON	104	ON	ON	OFF	ON	OFF	OFF	OFF
72	ON	OFF	OFF	ON	OFF	OFF	OFF	105	ON	ON	OFF	ON	OFF	OFF	ON
73	ON	OFF	OFF	ON	OFF	OFF	ON	106	ON	ON	OFF	ON	OFF	ON	OFF
74	ON	OFF	OFF	ON	OFF	ON	OFF	107	ON	ON	OFF	ON	OFF	ON	ON
75	ON	OFF	OFF	ON	OFF	ON	ON	108	ON	ON	OFF	ON	ON	OFF	OFF
76	ON	OFF	OFF	ON	ON	OFF	OFF	109	ON	ON	OFF	ON	ON	OFF	ON
77	ON	OFF	OFF	ON	ON	OFF	ON	110	ON	ON	OFF	ON	ON	ON	OFF
78	ON	OFF	OFF	ON	ON	ON	OFF	111	ON	ON	OFF	ON	ON	ON	ON
79	ON	OFF	OFF	ON	ON	ON	ON	112	ON	ON	ON	OFF	OFF	OFF	OFF
80	ON	OFF	ON	OFF	OFF	OFF	OFF	113	ON	ON	ON	OFF	OFF	OFF	ON
81	ON	OFF	ON	OFF	OFF	OFF	ON	114	ON	ON	ON	OFF	OFF	ON	OFF
82	ON	OFF	ON	OFF	OFF	ON	OFF	115	ON	ON	ON	OFF	OFF	ON	ON
83	ON	OFF	ON	OFF	OFF	ON	ON	116	ON	ON	ON	OFF	ON	OFF	OFF
84	ON	OFF	ON	OFF	ON	OFF	OFF	117	ON	ON	ON	OFF	ON	OFF	ON
85	ON	OFF	ON	OFF	ON	OFF	ON	118	ON	ON	ON	OFF	ON	ON	OFF
86	ON	OFF	ON	OFF	ON	ON	OFF	119	ON	ON	ON	OFF	ON	ON	ON
87	ON	OFF	ON	OFF	ON	ON	ON	120	ON	ON	ON	ON	OFF	OFF	OFF
88	ON	OFF	ON	ON	OFF	OFF	OFF	121	ON	ON	ON	ON	OFF	OFF	ON
89	ON	OFF	ON	ON	OFF	OFF	ON	122	ON	ON	ON	ON	OFF	ON	OFF
90	ON	OFF	ON	ON	OFF	ON	OFF	123	ON	ON	ON	ON	OFF	ON	ON
91	ON	OFF	ON	ON	OFF	ON	ON	124	ON	ON	ON	ON	ON	OFF	OFF
92	ON	OFF	ON	ON	ON	OFF	OFF	125	ON	ON	ON	ON	ON	OFF	ON
93	ON	OFF	ON	ON	ON	OFF	ON	126	ON	ON	ON	ON	ON	ON	OFF
94	ON	OFF	ON	ON	ON	ON	OFF	127	Node id will be the same as for the motor						

## 4.6 Expansion Mod. MAC00-FC2/FC4/FC41

### 4.6.13 Bus termination.

If a module is the last device on the CAN bus the module have a build-in terminator of 120 ohm. The dip switch (SW2) is used to enable termination. When both switches are on, the termination is enabled. In order to guarantee perfect operation of the CAN bus, bus terminating resistors must be provide at both ends of the bus cable.

The figure below shows the termination selection:

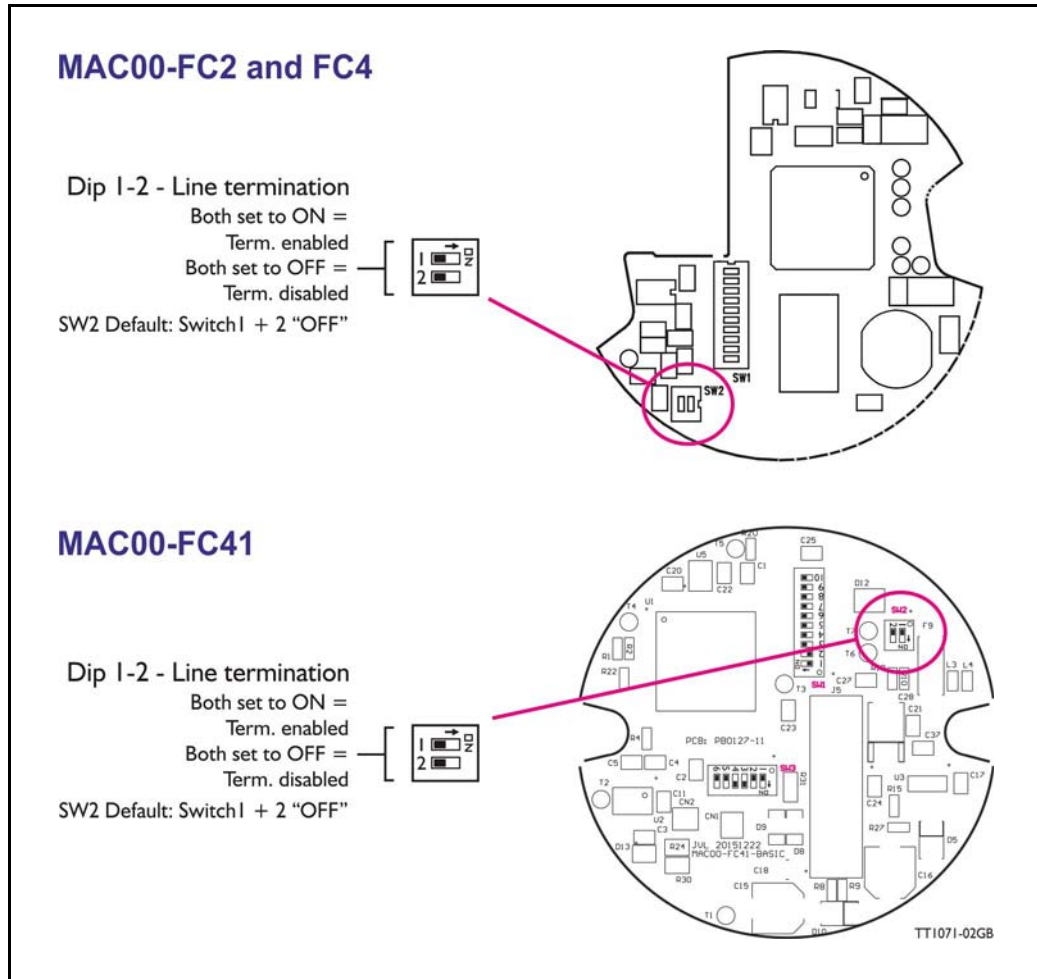

The factory default settings are OFF on both dip switches, and the line termination are off.



## 4.6 Expansion Mod. MAC00-FC2/FC4/FC41

---

### CAN bus connectors:

A typical connector used in CAN networks is the 9pin D-sub connector.

The MAC00-FC2/FC4/FC41 are not using this type of connector and none of the cables JVL supplies are provided with 9-pin D-sub.

But for users that need connection information to systems with 9pin D-sub the table below shows how to connect between the MAC module and the external D-sub.

Signal	Description	MAC00-FC2	MAC00-FC4/41	D-sub
-	Reserved			Pin 1
CAN_L	CAN_L bus line (Low)	B+	Pin 5	Pin 2
CAN_GND	CAN Ground	GND	Pin 3	Pin 3
-	Reserved			Pin 4
(CAN_SHLD)	Optional CAN Shield	GND	Pin 1	Pin 5
(GND)	Optional CAN Ground			Pin 6
CAN_H	CAN_H bus line (High)	A-	Pin 4	Pin 7
-	Reserved (error line)			Pin 8
CAN_V+	Optional CAN ext. + supply			Pin 9

## 4.6 Expansion Mod. MAC00-FC2/FC4/FC41

### 4.6.14 CanOpenExplorer program

The CanOpenExplorer is a program that was developed for internal use only, especially in the production, but the program has features that are nice to have, and make it more easily to start up the MAC motor when this is supplied with a MAC00-FC2/FC4 module. The program can write and send SDOs, PDOs, SYNC and heartbeat message, and finally it can read EDS files.

### 4.6.15 An overall method for communication test

Depending on which type of master and software solution there are available, shall these parts be available:

**PLC:** PLC with a CANopen® module and software that can communicate with this module. The CANopen® module shall be connected to a CAN bus, as shown in section 4.3.14 and section 4.3.15. To set up the master, download the EDS file from the JVL web page, see section 4.3.8. This file contains all register set-up data for the MAC module. The node-ID, the Baud-rate, and the termination resistor, has to be selected on the module, see from section 4.3.11 to section 4.3.13. And the power supply has to be connected to the motor as shown in section 3.2.5.

**PC:** PC with a CAN adaptor and software that can communicate with this module, or if the CanOpen Explorer software is used the PCAN-USB Dongle from Peak-system that is connected to a USB port on the PC. Peak systems web page are [www.peak-system.com](http://www.peak-system.com) here are a list of distributors. If MacTalk is used, the PC and the MAC module are connected via the RS232 interface on the MAC module. To set up the master, download the EDS file from the JVL web-page, see section 4.3.8. This file contains all register set-up in the MAC module. The node-ID, the Baud-rate, and the termination resistor, has to be selected physically on the module, see from section 4.3.11 to section 4.3.13, and the power supply has to be connected to the motor as shown in section 3.2.5.

If CanOpenExplorer is used, see the following method to test the motor communication:

- Load CanOpenExplorer.
- Connect the motor to the USB port via the Dongle.
- Connect power supply, see section 3.2.5.
- Run the CanOpenExplorer program on the PC.

- 1: Select the correct node ID, in the slave.
- 2: Select the EDS file, for all the MAC motors it is MAC00-fc.eds.
- 3: Load the EDS file by pressing load.

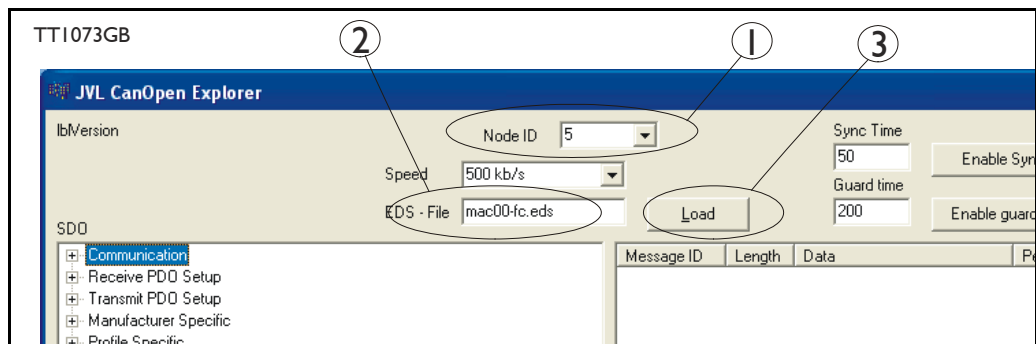

## 4.6 Expansion Mod. MAC00-FC2/FC4/FC41

- 4: Select here on the + the manufacturer specific register.
- 5: Select thereafter the object 0x2012. Object 0x2012 contains the motor parameters.

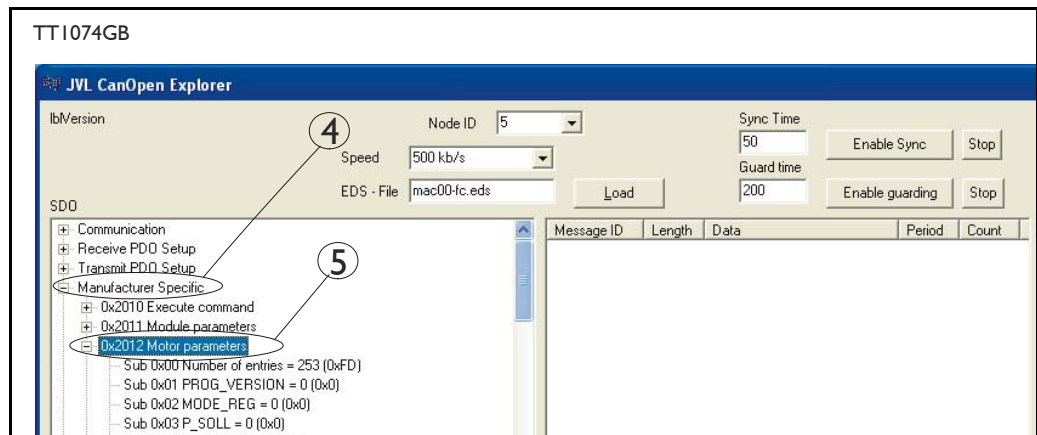

- 6: Point to the sub register 0x02, which is the register which determines in which mode the motor will operate.

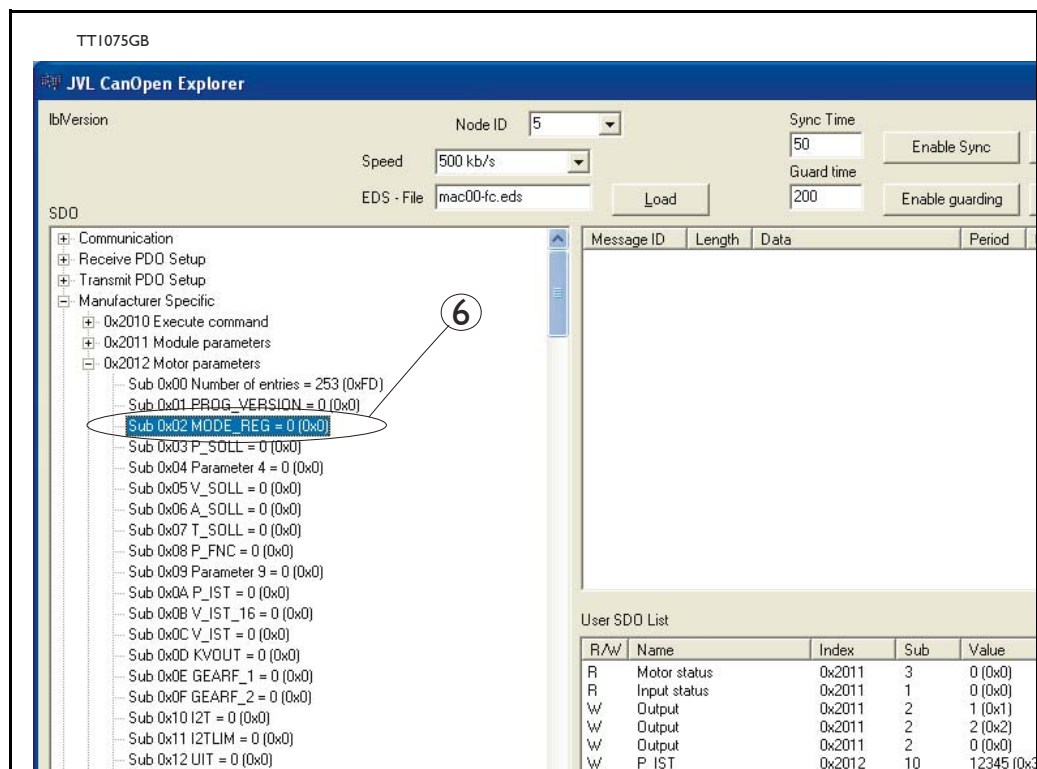

## 4.6 Expansion Mod. MAC00-FC2/FC4/FC41

Press W on the keyboard, and the following screen appears:

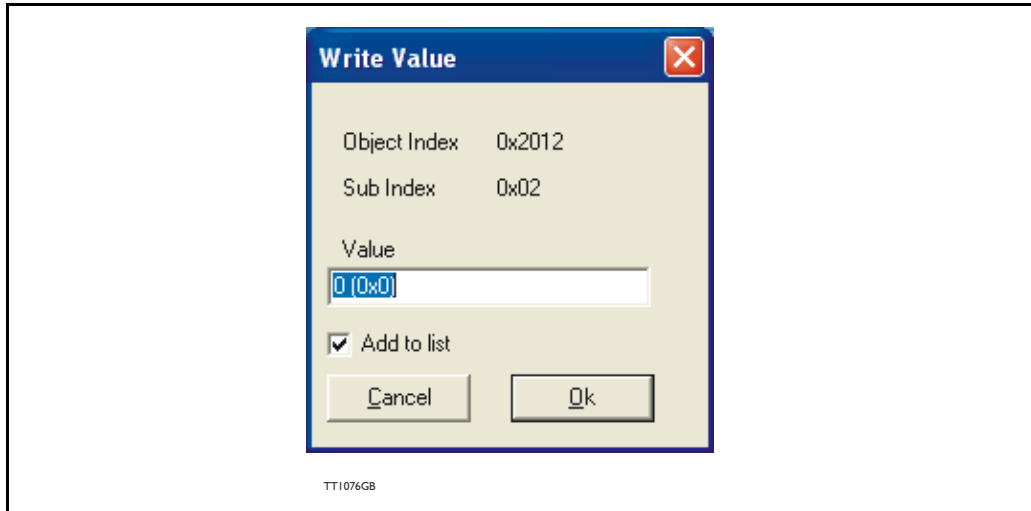

- 7: Type 02 in the window, and press OK.
- 8: Click on the sub register 0x05, which is the register to choose which velocity the motor will run in. Press W on the keyboard, type 100 in the window, and press OK. 100 is in Counts/Sample.
- 9: Click on the sub register 0x03, which is the register to choose which distance the motor shall run. Press on W on the keyboard, type 20000 in the window, and type OK. 20000 is in Encoder Counts

Now shall the motor shaft rotate slowly, until the motor has counted 20000 Encoder pulses. If you want to stop the motor, when click on sub register 0x02 and write 0 in the window, and it will switch to passive mode. Now it is possible to change the value in the register and change the speed and distance for the motor.

If using other software the test could be described as, (using object 2012h):

Sub-register	Name	Width	Unit	Operation	Value
02h	Mode_Reg	16 bit		Set up the motor in position mode	02h
05h	V_SOLL	16 bit	Counts/sample	Sets up the desired velocity	100h
03h	P_SOLL	32 bit	Encoder count	The motor rotates the desired numbers of encoder pulses	20000h
02h	Mode_Reg	16 bit		Sets the motor to passive mode	00h
Returning the motor with higher velocity					
02h	Mode_Reg	16 bit		Set up the motor in position mode	02h
05h	V_SOLL	16 bit	Counts/sample	Sets up the desired velocity	200h
03h	P_SOLL	32 bit	Encoder count	The motor rotates the desired numbers of encoder pulses	-20000h
02h	Mode_Reg	16 bit		Sets the motor in passive mode	00h

## 4.6 Expansion Mod. MAC00-FC2/FC4/FC41

---

### 4.6.16 How to use CanOpenexplorer

After startup, the name and details of the HW-interface, like PCAN\_USB should appear upper left.

When you turn on a motor/CAN node after having started CanOpenexplorer, the Data Window (large center right), there will come a message with the number 0x7xx, where xx is the node ID - for instance, 0x704 will indicate node 4. Set the Node ID field top center to that value (4).

Make sure the right EDS\_file is loaded. The program loads a hard-coded default file - either smc75.eds or mac00-fc.eds. It is also possible to load another EDS file by writing the file name in the "EDS file" field top center and pressing the load button. Note that the EDS view (large center left panel) will add the new file at the bottom but not clear the existing file(s) loaded.

Normal operation will be to select an object in the EDS view pane, and press either R for read or W for write. Pressing R should read the value, and that is successful if no error pops up. pressing w for write will pop up a small window, where the present value is displayed in both decimal and hex. It is then possible to write a new value either in decimal or in hex using a 0x prefix, like 0x185 to enable the first TPDO on node 5 (by clearing the high bit). If the Add to list checkbox is checked, the object will be added to the user SDO list as a write SDO. Pressing A performs a read and Adds it to the user SDO list pane (lower right) as a read SDO.

The SDOs in the user SDO pane can be rearranged by dragging them with the mouse. Double click on a user SDO list, will execute the operation, either reading or writing. The bus state can be changed using the NMT buttons lower left, like Operational to enable PDOs.

The button read user SDOs will read all of the "R" type object in the user SDO list. This is useful for updating a larger number of values in the EDS view.

The button read user SDOs will write all of the "W" type object in the user SDO list. This is useful for automated testing.

Entries can be deleted from the user SDO list by selecting them with the mouse and pressing the delete key.

The sync Time field top right sets the time in milli-seconds for the SYNC messages to be sent out. SYNCs can be started and stopped using the buttons Enable Sync and the Stop button to the right of it.

The Guard Time field below the Sync Time field works like SYNC-just for the Guarding message.

The close button exits the program after saving the list of user SDOs, which will be automatically reloaded on the next program start.

## 4.6 Expansion Mod. MAC00-FC2/FC4/FC41

### 4.6.17 MacTalk CAN debug window

The hardware CAN Node chip have a Node Control Register, this controls the initialization, defines the node specific interrupt handling and selects an operation mode. The Node Control Register have a field call LEC (Last Error Code), this bit field indicates if the latest CAN message has been correct (No error) or it indicates the type of error, which has been detected.

The register contains the following fields:

Bit	15-8	7	6	5	4	3	2	1	0
Field	0	BOFF	EWRN	0	RXOK	TXOK	LEC		
Read	X	X		X	X	X		X	
Write					X	X		X	

Where:

Field	Meaning	Value	Description
LEC	Last Error Code		See table below
TXOK	Message Transmitted Successfully	0	No successful transmission since last flag reset
		1	A message has been transmitted successfully (error free and acknowledged by at least one other node)
RXOK	Message Received Successfully	0	No successful reception since last flag reset.
		1	A message has been received successfully.
EWRN	Error Warning Status	0	No warning limit exceeded.
		1	One of the error counters in the Error Management Logic reached the error warning limit of 96
BOFF	Bus-Off Status	0	CAN controller is not in the bus-off state.
		1	CAN controller is in the bus-off state

Table for last Error code

LEC	Meaning	Description
000	No error	The latest transfer on the CAN bus has been completed successfully
001	Stuff error	More than 5 equal bits in a sequence have occurred in a part of a received message where this is not allowed
010	Form error	A fixed format part of a received frame has the wrong format
011	Ack error	The transmitted message was not acknowledged by another node
100	Bit1 error	During a message transmission the CAN node tried to send a recessive level (1), but the monitored bus value was dominant (outside the arbitration field and the acknowledge slot)
101	Bit0 error	Two different conditions are signaled by this code: 1. During transmission of a message (or acknowledge bit, active error flag, overload flag), the CAN node tried to send a dominant level (0), but the monitored bus value has been recessive. 2. During bus-off recovery, this code is set each time a sequence of 11 recessive bits has been monitored. The CPU may use this code as an indication, that the bus is not continuously disturbed
110	CRC error	The CRC check sum of the received message was incorrect
111	Reserved	

## 4.6 Expansion Mod. MAC00-FC2/FC4/FC41

Select the **MAC00-FCx** tab. See the figure below:

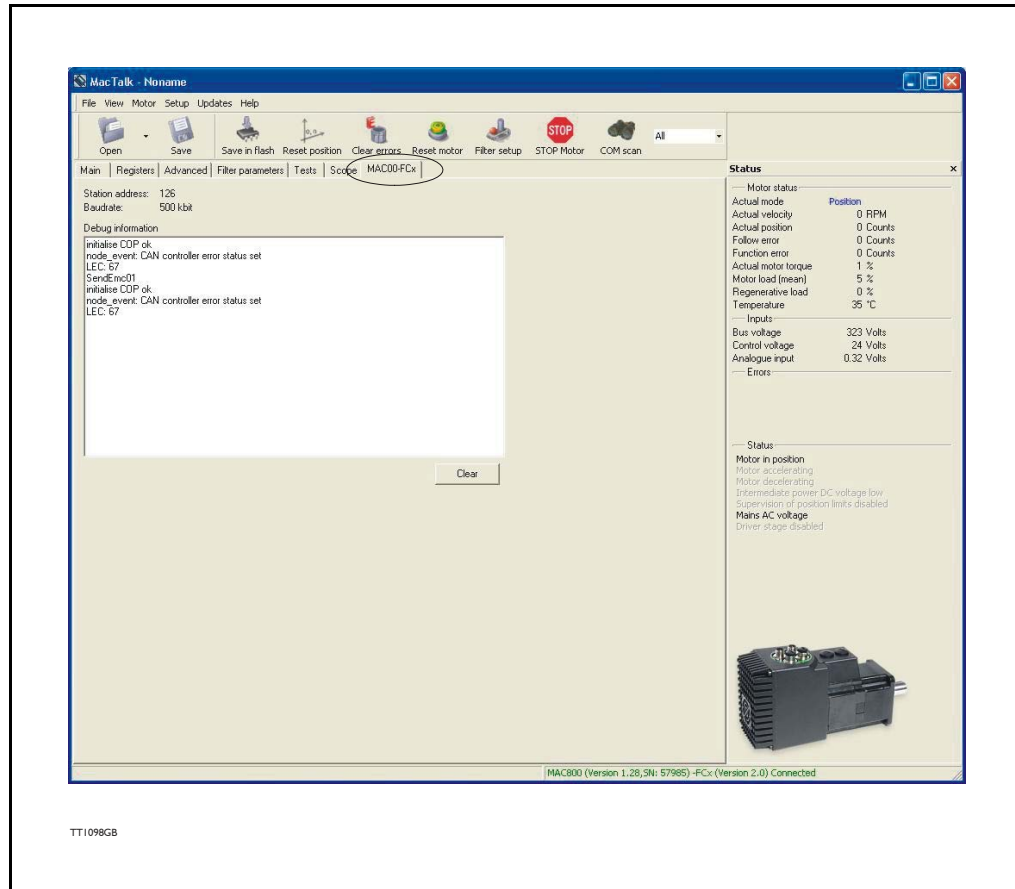

And example of an error message are shown in the figure above

On this error message is there a “Bit0 error” condition on the CAN bus, and the CAN bus is in the bus-off-state, and a error counter in EWRN has reached the error limits. To get this information convert 67h to binary 1100111.

## 4.6 Expansion Mod. MAC00-FC2/FC4/FC41

### 4.6.18 The DS301 specified Communications objects are:

The different communications objects are shown in table below, to get the default value in CanOpenExplorer, press on R on the keyboard, and the actual value will be shown.

Name	Index (hex)	Sub Index	Data Type	Read only	Default	Description
Device type	1000h		UNSIGNED32	X	0x20192h	Contains information about the device type. See note at top of next page. Mandatory.
Error Register	1001h		UNSIGNED8	X		This is the mapping error register, and it is part of the emergency object. If some of the sub index are high, an error has occurred. See also section <i>Object 2011h – Subindex 03h Motor status (U8)</i> , page 181
		0				Generic error. Mandatory
		1				Current (not supported)
		2				Voltage (not supported)
		3				Temperature (not supported)
		4				Communication (Overrun) (not supported)
		5				Device profile specific (not supported)
		6				Reserved (not supported)
		7				Manufacturer specific
Reservation register	1004h					Reservation of PDOs
		0		X		Reserved numbers of PDOs
		1		X		Reserved numbers of syncPDOs
		2		X		Reserved numbers of asyncPDOs
Manufacturer device name	1008h		VISIBLE STRING	X	JVL A/S	
Manufacturer hardware version	1009h		VISIBLE STRING	X	1.0	
Manufacturer software version	100Ah		VISIBLE STRING	X		Example: Version x.x
Guard time	100Ch		UNSIGNED16			Inform about the Guard time in milliseconds. Is only mandatory if the module does not support heartbeat
Life time factor	100Dh		UNSIGNED8			Is the factor, that guard time is multiplied with, to give the life time for the node guarding protocol
Heartbeat time	1017h		UNSIGNED8			If the Heartbeat timer is not 0, Heartbeat is used.
Identity object	1018h		IDENTITY	X		Contain general information about the module
		0	1..4	X	4h	Number of entries. Mandatory
		1	UNSIGNED32	X	0x0117h	Vendor ID, contains a unique value allocated to each manufacturer. 117h is JVLs vendor ID. Mandatory.
		2	UNSIGNED32	X	0x0100h	Product Code, identifies a specific device version. The MAC00-FCxx has the product code 100h
		3	UNSIGNED32	X	0x20020h	Revision number.
		4	UNSIGNED32	X		Serial number



## 4.6 Expansion Mod. MAC00-FC2/FC4/FC41

Note to “device type” (index 1000h).

The device type register is composed of 2 16-bit registers, one register describes which device profile the module is supports, and the other state which type of motors the module is supports, and possible I/O module. The default value 0192h inform that the DSP402 Device profile are supported, and the value 0002h announce that the MAC00-FCxx module supports servo drives.

### 4.6.19 Emergency object

The EMCY (emergency) object is used to transfer an error message to the CANopen® master, or also to another node which can process the error message. The reaction on the emergency object is not specified. An emergency object is transmitted only once per “error event”

The MAC00-FC supports the EMC object (Emergency).

The following error codes can be generated:

Errorcode 1001h: Generic error - Motor error

Errorcode 1002h: Generic error - Limit switch error

Errorcode 1003h: Generic error - Internal communication error

Errorcode 1004h: Generic error - Queue overflow in communication queue.

The EMCY object 1001h are sent as an 8 bit header, an have the following structure:

Byte 0	Byte 1	Byte 2	Byte 3	Byte 4	Byte 5 *	Byte 6 *	Byte 7
CANopen® error code: MSB 10	CANopen® error code: LSB 01	CANopen® 8-bit error register	MAC motor ERR_STAT MSB 16-bit error reg.	MAC motor ERR_STAT LSB 16-bit error reg.	MAC motor ERR_STAT Bit 23:16	MAC motor ERR_STAT Bit 31:24	Reserved

\* Only MAC400, 402, 800, 1500 and 3000.

#### Byte 0-1:

Shows which Generic error the module is sending.

#### Byte 2:

Error register. In the error register it is indicated to which error class the error belongs.

Bit No.	Error Class
Bit 0	Generic error. Mandatory
1	Current (not supported)
2	Voltage (not supported)
3	Temperature (not supported)
4	Communication (Overrun) - (not supported)
5	Device profile specific (not supported)
6	Reserved
7	Manufacturer specific

## 4.6 Expansion Mod. MAC00-FC2/FC4/FC41

### Byte 3-4

The ERR\_STAT register is located in the motor, not in the MAC00-FC2/4 module, but the SendEmc0I message is sent from the module firmware whenever it receives a status byte from the motor where the error-bit is set, it then reads register 35d from the motor.

When the error is no longer present, the module will send a NoError EMCY object once.

Byte 3 - bits description	
Bit 0	Overload
Bit 1	Follow error
Bit 2	Function error
Bit 3	Regenerative error
Bit 4	In position
Bit 5	Accelerating
Bit 6	Decelerating
Bit 7	Position

(Only Motor type MAC050 to I41)

Byte 4 - bits description	
Bit 0	Overload
Bit 1	Follow error
Bit 2	Function error
Bit 3	Regenerative error
Bit 4	In position
Bit 5	Accelerating
Bit 6	Decelerating
Bit 7	Position

(Only Motor type MAC400 to MAC3000)

Byte 4 - bits description	
Bit 0	Overload
Bit 1	Follow error
Bit 2	Function error
Bit 3	Regenerative error
Bit 4	In position
Bit 5	Accelerating
Bit 6	Decelerating
Bit 7	Position

## 4.6 Expansion Mod. MAC00-FC2/FC4/FC41

The EMCY object 1002h is sent as an 8 byte message, and has the following structure:

Byte 0	Byte 1	Byte 2	Byte 3	Byte 4	Byte 5	Byte 6	Byte 7
CANopen® error code: MSB 10	CANopen® error code: LSB 02	CANopen® 8-bit error register	0	0	0	0	0

EMCY/object 1002h is sent when any of the HW end limits are active. No additional information in bytes 3-7.

The EMCY object 1003h is sent as an 8 byte message, and has the following structure:

Byte 0	Byte 1	Byte 2	Byte 3	Byte 4	Byte 5	Byte 6	Byte 7
CANopen® error code: MSB 10	CANopen® error code: LSB 03	CANopen® 8-bit error register	0	0	0	0	0

EMCY/object 1003h is sent when internal communication between the module and the motor has been disconnected.

The EMCY object 1004h is sent as an 8 byte message, and has the following structure:

Byte 0	Byte 1	Byte 2	Byte 3	Byte 4	Byte 5	Byte 6	Byte 7
CANopen® error code: MSB 10	CANopen® error code: LSB 04	CANopen® 8-bit error register	0	0	0	0	0

EMCY/object 1004h is sent in case of overflow in the communications queue between the module and the motor.

In MAC00-FCxx none of the error control is enabled then the modules are started up, because if there is any fault in the system it is impossible to get in contact with the module. After the module has started up and there is communication between the master and the slave, then turn on the wanted error control mechanism in the object Dictionary, see section 4.3.20.

## 4.6 Expansion Mod. MAC00-FC2/FC4/FC41

### 4.6.20 Manufacturer specific object dictionary

	Index (hex)	Sub Index	Type	Read only	Default	Description
<b>Command</b>	2010h	0	UNSIGNED 8			Execute a MAC00-FCx command
<b>Module parameters</b>	2011h	0	UN-SIGNED 8	X	8	Subindex count
		1	UNSIGNED 8	X		Input status IN1 - IN4, NL, PL
		2	UN-SIGNED 8			Output
		3	UN-SIGNED 8	X		Motor Status
		4	UN-SIGNED16	X		Last Motor Error
		5	UN-SIGNED 8			Output setup
		6	UN-SIGNED 8		0x3Fh	Input active level
		7	UN-SIGNED 8			Input setup
		8	UN-SIGNED 8			Setup bits
<b>Motor parameters</b>	2012h	0	UN-SIGNED 8	X	254d	Subindex count
		n	UN-SIGNED 32			Access to the motor parameter n
<b>FastMac Command</b>	2013h	0	UN-SIGNED 8			Executes a FastMac command
<b>Homing Torque</b>	2100h	0	UN-SIGNED 16		1000d	Defines the torque limit used during homing with DSP-402

Writing to these object in CanOpenExplorer is done by pressing W, on the keyboard when the register in the folder Manufacturer specific is selected. Reading is done by pressing R.

#### 4.6.21 Object 2010h - Subindex 0 Reset

When writing to this object (sub index 0), it is possible to execute some special commands for the MAC00-FCx module. The following commands are available:

---

<b>Number</b>	<b>Function</b>
0	No operation
1	Reset limit error
2	Reset communication error
3 + 4	Reserved for MacTalk debugging
5	Reset module only - the basic motor will not be reset
6	Sync. reset module + motor
7-255	Reserved

## 4.6 Expansion Mod. MAC00-FC2/FC4/FC41

### 4.6.22 Object 2011h – Subindex 01h Input status (U8)

This object is used to read out the actual value of the inputs.

Bit	7	6	5	4	3	2	1	0
Input	Reserved	CAN V+	PL	NL	IN4	IN3	IN2	IN1

*PL* is the positive limit switch input, and *NL* is the negative limit switch input. *IN1-*IN4** is the digital user inputs. The *CAN V+* bit reflects the actual voltage level at the *CAN V+* terminal which can be supplied with 0V (or unconnected) or 24VDC nominal. On the MAC00-FC2 module the inputs are connected via J2, and on the MAC00-FC4 or FC41 modules the input is connected via the M12 connectors marked I/O.

### 4.6.23 Object 2011h – Subindex 02h Outputs (U8)

With this object the outputs can be controlled.

The value written to this object is directly shown on the outputs if the outputs are not set to use the default function (see subindex 5).

Bit	7	6	5	4	3	2	1	0
Output	Reserved						O2	O1

O1 and O2 are the digital user output 1 and 2. On the MAC00-FC2 module the outputs are connected via J4, and on the MAC00-FC4 module the outputs are connected via the M12 connectors marked I/O.

### 4.6.24 Object 2011h – Subindex 03h Motor status (U8)

With this object the status of the motor can be monitored.

Bit	7	6	5	4	3	2	1	0
Data	Reserved	Deceleration	Acceleration	In position	Reserved	Limit switch Error	Disconnected	Motor Error

Bit 6: Equals 1, if the velocity is decreasing.

Bit 5: Equals 1, if the velocity is increasing.

Bit 4: Equals 1, if the motor is at the commanded position.

Bit 2: Equals 1, if a limit switch has been activated.

Bit 1: Equals 1, if there is a communication error between the MAC00-FC and the motor. This could occur if the motor has been reset due to a voltage drop.

Bit 0: Equals 1, if there is a fatal motor error. Read subindex 4 to get extended information.

## 4.6 Expansion Mod. MAC00-FC2/FC4/FC41

### 4.6.25 Object 2011h – Subindex 04h Last motor status (U16)

When a fatal motor error occurs, the ERR\_STAT register from the MAC motor is received and can be read from this object.

Notice that LOWORD only for MAC400, 402, 800, 1500 and 3000.

Recommended only to read ERR\_STAT from motor.

Motor status table:

Bit 0	Overload
Bit 1	Follow error
Bit 2	Function error
Bit 3	Regenerative error
Bit 4	In position
Bit 5	Accelerating
Bit 6	Decelerating
Bit 7	Position

### 4.6.26 Object 2011h – Subindex 05h Output setup (U8)

This object is used to control the function of the outputs. When bit 3:2 = 0, the outputs are controlled by the object 2011h, subindex 2.

When bit 3:2 = 1 (default), the output is controlled by the default function. The default function for O1 is “In position” and for O2 “Error”.

Bit	7	6	5	4	3	2	1	0
Output	Reserved				Enable user write to O2	Enable user write to O1	O2	O1

### 4.6.27 Object 2011h – Subindex 06h Input active level (U8)

With this object the active level of the inputs can be selected. When bit x = 0, the input is active low and when bit x = 1, the input is active high.

The default setup for the output is active high.

Bit	7	6	5	4	3	2	1	0
Input	Reserved		PL	NL	IN4	IN3	IN2	IN1

## 4.6 Expansion Mod. MAC00-FC2/FC4/FC41

### 4.6.28 Object 2011h – Subindex 07h Input setup (U8)

With this object the dedicated function of the inputs can be enabled. When the corresponding bit is 0, the input functions as a normal input. When the corresponding bit is 1, the dedicated function of the input will be enabled. When the end limit inputs NL or PL are enabled and one of these is activated, the error action will be executed. The error action is defined in object 2011h subindex 8.

Bit 1 - “Input Mirror”. Setting this bit will transfer the state of the inputs NL, PL, IN1-4 to the “Input” register in the basic motor. This is useful if the inputs are used in for example a “eRxP” program (graphic programming).

Notice that only MAC00-FCx Firmware newer than 3.00 supports this feature.

Bit	7	6	5	4	3	2	1	0
Input	Reserved		PL	NL	Reserved		Input Mirror	

### 4.6.29 Object 2011h – Subindex 08h Setup bits (U8)

This object is used for auxiliary setup of the module

Bit	7	6	5	4	3	2	1	0
Setup	Endless relative	Error action	DISAB_402_CW	USRERR_ACK	SCAN_ANINP	SCAN_VF_OUT	SCAN_V_IST	SCAN_P_IST

Bit 0: SCAN\_P\_IST: When this bit is 1, the P\_IST is scanned all the time. The transmit PDO21 will then send the last scanned position instead of reading the position.

Bit 1: SCAN\_V\_IST: When this bit is 1, the V\_IST is scanned all the time. The transmit PDO22 will then send the last scanned velocity instead of reading the velocity.

Bit 2: SCAN\_VF\_OUT: When this bit is 1, the VF\_OUT (actual motor torque) is scanned all the time. The transmit PDO23 will then send the last scanned torque instead of reading the torque from the motor. Only valid from firmware version 3.02.

Bit 3: SCAN\_ANINP: When this bit is 1, the ANINP (analogue input register) is scanned all the time. The transmit PDO24 will then send the last scanned value instead of reading the analogue value register which takes additional time.

Bit 4: USRERR\_ACK: If set, the motor will require the user to clear/acknowledge a heartbeat error before the motor can turn again. This is a safety measure required in some applications. Only valid from firmware version 3.02.

Bit 5: DISAB\_402\_CW: Disables the DSP402 control word in PDO 3 to 7.

Bit 6: Error action: 0 = set motor in passive mode, 1 = stop motor by setting velocity to zero.

Bit 7: Endless relative: When this bit is 1, the endless relative position mode is used when doing relative positioning in DSP402. When using this mode, absolute positioning can no longer be used.



## 4.6 Expansion Mod. MAC00-FC2/FC4/FC41

---

### 4.6.30 Object 2011h – Subindex 09h Setup bits 2 (U16)

This subindex holds several configuration bits.

Bit-0: TxPDO22 combines Actual velocity and Actual Torque. Instead of standard Actual Velocity.

Bit-1: Will execute the operation selected for error (Passive mode or set Max. Velocity to zero) when there is a BusOff condition, and then reinitialize the CAN system to clear the condition and reset error counters for receive and transmit errors. If this bit is zero, only the re-initialization will be executed, but the motor can continue running during the re-initialization and cannot be controlled from the CAN line until the re-initialization has finished and the CAN master has performed initialization of PDOs and other object used.

Bit-2: Reserved.

Bit-3: Reserved.

Bit-4: Selects to auto-read the register selected by object 0211-subindex 13 (decimal). This makes it usable with Event Timer transmission and for generally faster response to SYNC'ed TxPDO23.

Bit-5: Selects to auto-read the register selected by object 0211-subindex 14 (decimal). This makes it usable with Event Timer transmission and for generally faster response to SYNC'ed TxPDO24.

Bit-6: Reserved.

Bit-7: Reserved.

### 4.6.31 Object 2011h – Subindex 0Ah Reserved 2 (U16)

Reserved for future use.

### 4.6.32 Object 2011h – Subindex 0Bh UserReg16RcvSelect (U8)

Reserved for future use.

### 4.6.33 Object 2011h – Subindex 0Ch UserReg16RcvSelect (U8)

Reserved for future use.

### 4.6.34 Object 2011h – Subindex 0Dh UserReg1XmitSelect (U8)

If set non-zero, holds the register number to be transmitted in TxPDO23.

This will automatically change the length of TxPDO23 from 2 to 6 bytes.

### 4.6.35 Object 2011h – Subindex 0Eh UserReg2XmitSelect (U8)

If set non-zero, holds the register number to be transmitted in TxPDO24.

This will automatically change the length of TxPDO24 from 2 to 6 bytes.

### 4.6.36 Object 2011h – Subindex 0Fh UserReg16RcvData (U16)

Reserved for future use.

## 4.6 Expansion Mod. MAC00-FC2/FC4/FC41

---

### 4.6.37 Object 2011h – Subindex 10h UserReg32RcvData (U32)

Reserved for future use.

### 4.6.38 Object 2011h – Subindex 11h (U16)

A new sub-index 11h was added to object 0x2011. This is a 16-bit unsigned value, intended for a set of error bits that are set when CAN bus errors are detected. So far, we only use bit 0 to indicate missing heartbeat from at least one monitored node.

As long as at least one bit is set in this register, the selected error action is performed repeatedly every few ms (either setting the motor in Passive mode or setting the V\_SOLL to zero).

The user must then zero this 2011h-subindex 11h register via SDO write to continue operating the motor. He must also set the motor back into an active mode or set V\_SOLL to a non-zero value – this is not done/restored automatically.

This condition can only be reset over CAN – not from the built-in motor program or MacTalk. After power on, or software/hardware reset, the errors will also be cleared.

## 4.6 Expansion Mod. MAC00-FC2/FC4/FC41

### 4.6.39 Object 2012h – Motor parameters

With this object all the registers of the MAC motor can be accessed. All the registers are accessed as 32 bit. When reading and writing to 16 bit registers, the values are automatically converted in the module. In addition to these features listed in the table below, many more are accessible. In total, the MAC motor contains more than 150 internal registers such as nominal velocity, actual position, etc. But please note that several registers are not for the normal user and damage may occur if the contents of these registers is changed. The table shows the most commonly used registers.

Sub-index (Hex)	Name	Data type	Read/Write	Default (HEX)	Unit	Description
00h	Number of entries	UNSIGNED8	Read	FDh		
01h	PROG_VERSION	VISIBLE_STRING	Read	78h		
02h	MODE_REG	UNSIGNED16	Write			0: Passive mode 1: Velocity mode 2: Position mode 3: Gear mode 4: Analog Torque mode 5: Analog Velocity mode 6: Analog Velocity/Gear mode 7-11: Reserved 12: Torque Zero Search 13: Sensor type1 Zero search 14: Sensor type2 Zero search
03h	P_SOLL	UNSIGNED32	Write		Encoder counts	The commanded position
05h	V_SOLL	UNSIGNED16	Write		Counts/sample	Desired velocity
06h	A_SOLL	UNSIGNED16	Write		Counts/sample <sup>2</sup>	The maximum allowed acceleration
07h	T_SOLL	UNSIGNED16	Write			The maximum allowed torque
0Ah	P_IST	UNSIGNED32	Read		Encoder counts	The actual position
0Ch	V_IST	UNSIGNED16	Read		Counts/sample	The actual velocity
0Eh	GEAR_1=0	Integer	Write			Gear output factor used in gear mode
0Fh	GEAR_2=0	Word	Write			Gear input factor used in gear mode
10h	I2T	Word	Read			Motor temperature calculated
11h	I2tLIM	Word	Read			Error trip level used for I2T register
1Ch	MIN_P_IST	Long int	Read		Encoder counts	Software position limit-positive

Continued next page

## 4.6 Expansion Mod. MAC00-FC2/FC4/FC41

Sub-index (Hex)	Name	Data type	Read/Write	Default (Hex)	Unit	Description
1Eh	MAX_P_IST	Long int	Read		Encoder counts	Software position limit negative
20h	ACC_EMERG	Word	Write		Counts/sample <sup>2</sup>	The maximum allow deceleration when a Unrecoverable error has occurred
21h	INPOSWIN	Word	Write		Encoder counts	If actual position is within this window, the motor is in position
22h	INPOSCNT	Word			Samples	The number of samples the motor has to be within the pos. interval spec.in INPOSWIN
23h	ERR_STAT	Unsigned16	Read			Motor status: Bit 0: Overload Bit 1: Follow error Bit 2: Function error Bit 3: Regenerative error Bit 4: In position Bit 5: Accelerating Bit 6: Decelerating Bit 7: Position limits error

### 4.6.40 Object 2013h – Subindex 00h FastMac command.

When writing to this object, a FastMac command is executed. Please refer to the MAC00-FPx section for a description of the FastMac commands.

### 4.6.41 Enable and Disable PDOs

In the CANOpen® profile it is only possibly to have four transmit and four receive PDOs enabled at the same time. In the MAC00-FCxx all PDOs are disabled when the module is booted up, the user has to choose which PDOs the application will use, and enable these.

To enable or disable a PDO it is necessary to write to the MSB (bit 31) in the PDO COB-ID entry in the PDO communication parameter Record. The COB-ID register is sub-index 1h, and the value range of this register is UNSIGNED32.

The PDOs are enabled when bit 31 is 0, and is disabled when bit 31 is 1.

## 4.6 Expansion Mod. MAC00-FC2/FC4/FC41

The table below shows default value of the COB-ID:

PDO	Sub-index	Type	Description	Default	Access type
21d	1	Receive	COB-ID	Nodeid+0x80000200	r/w
	1	Transmit	COB-ID	Nodeid+0x80000180	r/w
22d	1	Receive	COB-ID	Nodeid+0x80000300	r/w
	1	Transmit	COB-ID	Nodeid+0x80000280	r/w
23d	1	Receive	COB-ID	Nodeid+0x80000400	r/w
	1	Transmit	COB-ID	Nodeid+0x80000380	r/w
24d	1	Receive	COB-ID	Nodeid+0x80000500	r/w
	1	Transmit	COB-ID	Nodeid+0x80000480	r/w
25d	1	Transmit	COB-ID	Nodeid+0x80000480	r/w

Remark: Some PLC's count PDO's starting from 1. Other PLC's count from 0. If counting from 0 please subtract 1 from the above mentioned PDO numbers.

### 4.6.42 Receive PDOs

The PDOs 1-20 are reserved for use with the DSP-402 (CANopen® motion control profile). The following receive PDOs are available:

#### Receive PDO 21d:

This PDO can be used to update the position. The data in the PDO is written directly to the position register and if the motor is in position mode, it will start moving to that position.

Byte	0	1	2	3	4	5	6	7
Data	P_SOLL				Reserved	Reserved	Reserved	Reserved
Object	2012h, sub 3							

#### Receive PDO 22d:

With this PDO it is possible to update the velocity, acceleration and torque.

Byte	0	1	2	3	4	5	6	7
Data	V_SOLL		A_SOLL		T_SOLL		MODE_REG	
Object	2012h, sub 5		2012h, sub 6		2012h, sub 7		2012, sub 2	

#### Receive PDO 23d:

This PDO sets a new operating mode for the motor.

Byte	0	1	2	3	4	5	6	7
Data	FastMac Command	Reserved	Reserved	Reserved	Reserved	Reserved	Reserved	Reserved
Object	2013h, sub 0							

Add 96 to the FastMac command number. For example command 23 becomes 119 (decimal). 96 + 28 (decimal) will reset the module (only)

## 4.6 Expansion Mod. MAC00-FC2/FC4/FC41

### Receive PDO 24:

This PDO updates the outputs.

Byte	0	1	2	3	4	5	6	7
Data	Output data	Reserved	Reserved	Reserved	Reserved	Reserved	Reserved	Reserved
Object	2011h, sub 2							

### 4.6.43 Transmit PDOs

The transmit PDOs 1-20 are reserved for use with the DSP-402 (CANopen® motion control profile).

All of the transmit PDOs support synchronous transmission, and PDO 25 also supports asynchronous transmission.

JVL uses static mapping of the PDOs, but with some manufacturer specific ways to make some of the PDOs use registers selectable by the user. After reset all the PDOs are disabled, because the highest bit in their COB-ID field is set. The user must then select what PDOs to use by writing valid COB-ID values in addition to selecting Transmission type as SYNC'ed or Event Timer with period in ms, and then change the node into Operational state for the PDOs to start operating.

The EDS files delivered from JVL describes only the standard static mapping as after reset. In system that actually use the EDS file, and depend on it to be correct, it will be necessary to edit the EDS file in a text editor to describe the selected manufacturer specific mapping. Many systems either don't use the EDS file at all, or use it only to make it easier to configure the system.

### Transmit PDO 21:

With this PDO the actual position can be read.

Byte	0	1	2	3	4	5	6	7
Data	P_IST			Motor Status	Inputs	Reserved	Reserved	
Object	2012h, sub 10			2011h, sub 3	2011h, sub 1			

### Transmit PDO 22:

With this PDO the actual velocity can be read.

Byte	0	1	2	3	4	5	6	7
Data	V_IST		(VF_OUT)		Reserved	Reserved	Reserved	Reserved
Object	2012h, sub 12							

() : VF\_OUT only available if option bit is set in subindex

## 4.6 Expansion Mod. MAC00-FC2/FC4/FC41

### Transmit PDO 23d:

With this PDO the actual torque can be read.

Byte	0	1	2	3	4	5	6	7
Data	VF_OUT		UserReg1XmitSelect !=0			Reserved		Reserved
Object	2012h, sub 121							

### Transmit PDO 24d:

With this PDO the value of the analog input can be read.

Byte	0	1	2	3	4	5	6	7
Data	ANINP		UserReg2XmitSelect !=0			Reserved		Reserved
Object	2012h, sub 122							

### Transmit PDO 25d:

With this PDO the motor status, inputs and last error can be read.

This PDO also supports asynchronous transmission. If this PDO is in asynchronous mode, it will be transmitted every time the run status or inputs are changed.

Byte	0	1	2	3	4	5	6	7
Data	Motor Status	Inputs	Last motor error		Reserved	Reserved	Reserved	Reserved
Object	2011h, sub 3	2011h, sub 1	2011h, sub 4					

### 4.6.44 Transmission time

Due to the internal communication between the motor and the MAC00-FCx, the PDOs takes a certain time to process. The following table shows the processing time for the PDOs.

The table with 8.5 and 21 ms are valid for the MAC050 – MAC141, and for MAC400 and higher with firmware versions below 2.0. With MAC400 and higher with firmware 2.0 and higher, the table with <2 ms will be valid. Still it would be possible to overload the internal communications line if many data objects are read with short intervals. The general rule of thumb is that up to seven motor registers can be read every 2 ms.

PDO number	21	22	23	24	25
Receive PDO	< 2ms (8.5ms)	< 2ms (21ms)	<1ms	<1ms	-
Transmit PDO	12.5ms (<1ms)*	10.5ms (<1ms)**	10.5ms	10.5ms	<1ms

(): Only valid for MAC050 to MAC141. All timing values based on MAC00-FCx firmware V3.0 or newer.

\* : Note that Transmit PDO21d is faster if P\_IST scanning is enabled. (See object 2011h subindex 8).

\*\* : Note that Transmit PDO22d is faster if V\_IST scanning is enabled. (See object 2011h subindex 8).

## **4.6 Expansion Mod. MAC00-FC2/FC4/FC41**

---

If the received PDOs are transmitted faster than the internal processing time, an internal queue overflow occurs (See emergency object). If the SYNC object interval is smaller than the processing time of the active transmit PDOs, an internal queue overflow error occurs.



## 4.6 Expansion Mod. MAC00-FC2/FC4/FC41

---

### 4.6.45 DSP-402 Support

#### Introduction

The MAC00-FCx supports the DSP-402 standard from CiA® (<http://www.can-cia.com/>).

Please refer to this standard for full details of the functions.

The DSP-402 is only a standard proposal and might be changed in the future. We reserve the right to change future firmware versions to conform to new versions of the standard. Not all of the functionality, described in DSP-402, is supported. But all the mandatory functions are supported.

The following operation modes is supported:

- Profile position mode
- Velocity mode
- Homing mode

#### Precondition:

Before the DSP-402 mode can be used, the firmware in the FCx module must be updated to at least version 1.3.

The start mode of the motor must be set to passive.

No power up *Zero searches* must be selected.

If absolute movement is used, the 'resynchronize after passive mode' must be set.

When using DSP-402 mode, manipulating parameters with object 2012h or 2013h can corrupt the behaviour of the DSP-402 functions. Also be aware that manipulating parameters in MacTalk should be avoided when using DSP-402.

## 4.6 Expansion Mod. MAC00-FC2/FC4/FC41

### 4.6.46 Supported objects

Most of the DSP402 parameters start up in the module with-coded values. A few of them are set depending on the motor type the module is attached to - either MAC50-141 or MAC400-800. None of the parameters can be saved to flash in the module.

The following table shows the additional object dictionary defined for DSP-402 support. The numbers in brackets, in the update/write field, **bold**, refer to the formula for the factors in the section 4.3.40

Name	Desc	COB ID (hex)	Sub-index	Motor register	InitValue	Scalefactor to motor	Update/write
<b>Device data</b>							
Motor_type		6402h	0		10		
Motor_catalog_number		6403h	0		MACxxx		
Motor_manufacturer		6404h	0		JVL A/S		
http_motor_catalog_address		6405h	0		www.JVL.dk		
Supported_drive_modes		6502h	0		45		
Drive_catalog_number		6503h	0		MACxxx		
Drive_manufacturer		6504h	0		JVL A/S		
http_drive_catalog_address		6505h	0		www.JVL.dk		
<b>Digital I/O</b>							
Digital_inputs		60FDh	0	Motor status			When HW inputs or motor status (change) See formula (6) in section 4.3.40
Digital_outputs_numbers_of_entries		60FEh	0		2		
Digital_outputs_Physical_outputs		60FEh	1	HW output	0		Imm. See formula (7) in section 4.3.40
Digital_outputs_Bit_mask		60FEh	2	HW output	0		Imm. See formula (7) in section 4.3.40
<b>Device control</b>							
Abort_connection_option_code	N/U	6007h	0				
Error_code	N/U	603Fh	0				
Controlword		6040h	0				
Statusword		6041h	0				
Quick_stop_ortion_code		605Ah	2				Used in state machine
Modes_of_operation		6060h	0				
Mode_of_operation_display		6061h	0				
<b>Profile Position parameters</b>							
Position_actual_value		6064h	0			1/Position_factor	BusyRead
Target_position		607Ah	0	P1		Position_factor	Positionmode when bit in Controlword is set
Software_position_limit_number_of_entries		607Dh	0		0		
Software_position_limit_Min_position_limit		607Dh	1		0		0
Software_position_limit_Max_position_limit		607Dh	2		0		0
Position_window		6067h	0	Z1	100	Position_factor	Imm.
Position_window_time		6068h	0	INPOSCNT	6	SamleFreq/1000	Imm
Max_motor_speed	N/U	6080h	0		5000 or 4000		
Profile_velocity	N/U	6081h	0	V1	100	Velocity_factor	Imm
Profile_acceleration		6083h	0	A1	15000	Acceleration_factor	Imm
Quick_stop_deceleration		6085h	0	A2	50000	Acceleration_factor	Imm
Motion_profile_type	N/U	6086h	0		0		

Continued on next page

## 4.6 Expansion Mod. MAC00-FC2/FC4/FC41

Name	Desc	COB ID (hex)	Sub-index	Motor register	Initial Value	Scalefactor to motor	Update/write
<b>Profile velocity mode</b>							
Velocity_sensor_actual_value		6069h	0	V_IST			BusyRead
Velocity_demand_value	N/U	606Bh	0				(Copied from target velocity on updated)
Velocity_actual_value		606Ch	0	V_IST		1/(Velocity_factor*16)	BusyRead
Velocity_window		606Dh	0	Z1	100	Velocity_factor/16	Imm
Velocity_window_time		606Eh	0	INPOSCNT	6	SampleFreq/1000	Imm
Target_velocity		60FFh	0	V1	50	Velocity_factor or Velocity_factor depending on polarity	Imm + Start-Velocity mode
Max_torque		6072h	0	T1 and TSOLL	1000	1.023	Imm
<b>Homing mode</b>							
Home_offset		607Ch	0	P_HOME			During homing See (8) in section 4.3.40
Homing_method		6098h	0				See homing describ.
Homing_speeds_number_of_entries	RO	6099h	0		2		
Homing_speeds_Speeds_during_search_for_switch		6099h	1	V1	50	+/- Velocity_factor	At homing
Homing_speeds_Speeds_during_search_for_zero		6099h	2	V2	50	Velocity_factor	At homing
Homing_acceleration		609Ah	0	ASOLL	5000	Acceleration_factor	At homing
<b>Factors</b>							
Position_notation_index	N/U	6089h	0		0		
Position_dimension_index	N/U	608Ah	0		0xAC		
Velocity_notation_index	N/U	608Bh	0		0		
Velocity_dimension_index	N/U	608Ch	0		0xA4		
Acceleration_Notation_index	N/U	608Dh	0		0		
Acceleration_dimension_index	N/U	608Eh	0		0		
Position_encoder_resolution_number_of_entries	RO	608Fh	0		2		
Position_encoder_resolution_Encoder_increment		608Fh	1		4096 or 8000		Not CF_Upd. >Position_factor
Position_encoder_resolution_Motor_revolution		608Fh	2		1		CF_Upd. >Position_factor
Velocity_encoder_resolution_number_of_entries	RO	6090h	0		2		
Velocity_encoder_resolution_encoder_increments_per_second	N/U	6090h	1		4096 or 8000		
Velocity_encoder_resolution_motor_resolution_s_per_second	N/U	6090h	2		1		
Gear_ratio_number_of_entries	RO	6091h	0		2		
Gear_ratio_Motor_revolutions		6091h	1				CF Upd.> Position_factor
Gear_ratio_Shaft_revolutions		6091h	2				CF Upd.> Position_factor
Feed_constant_number_of_entries	RO	6092h	0		2		See formula (4) in section 4.3.40
Feed_constant_Feed	N/U	6092h	1		4096 or 8000		In CF_Upd
Feed_constant_Shaft_revolutions		6092h	2		1		CF Upd. >Position_factor >Feed_constant >PFactorNumerator
Position_factor_number_of_entries	RO	6093h	0		2		See formula (1) in section 4.3.40
Position_factor_Numerator	N/U	6093h	1		1		In CF_Upd See formula (5) in section 4.3.40
Position_factor_Feed_constant		6093h	2				

Continued on next page

## 4.6 Expansion Mod. MAC00-FC2/FC4/FC41

Name	Desc.	COB ID (hex)	Sub-index	Motor register	Initial Value	Scalefactor to motor	Update/write
Velocity_encoder_factor_number_of_entries	RO	6094h	0		2		See formula (2) in section 4.3.40
Velocity_encoder_factor_Numerator		6094h	1		4096 or 8000		CF_Upd, >Velocity_factor
Velocity_encoder_factor_Divisor	RPM	6094h	2		60		CF_Upd, >Velocity_factor
Acceleration_factor_number_of_entries	RO	6097h	0		2		See formula (3) in section 4.3.40
Acceleration_factor_Numerator		6097h	1		4096 or 8000		CF_Upd.>Acceleration_factor
Acceleration_factor_Divisor	RPM	6097h	2		60		CF_Upd Acceleration_factor
Polarity	Bit7: InvPos. Bit6: InvVel.	607Eh	0				CF_Upd, >Position_factor >Velocity_factor
SampleFreq					520.833 or 770		Not CF_Upd, >Velocity_factor >Acceleration_factor
Homing_Torque		2100h	0	T_HOME	500 in V2.0, 30 in V2.1	1.023	At start of homing
<b>Module Parameters:</b>							
Inputs status		2011h	1				See section 4.3.24
Outputs		2011h	2		0		See section 4.3.25
Motor status		2011h	3				See section 4.3.26
Last motor status		2011h	4		0		See section 4.3.27
Output setup		2011h	5		0		See section 4.3.28
Input active level		2011h	6		0x3F		See section 4.3.29
Input setup		2011h	7		0		See section 4.3.30
Setup bits		2011h	8				See section 4.3.31
Data (256 motor registers)		2012h	x				See section 4.3.32
Fastcommand (Send FastMac command)		2013h	0				See section 4.3.33

## 4.6 Expansion Mod. MAC00-FC2/FC4/FC41

### 4.6.47 Factors

#### Position\_factor. (1) in section 4.3.39

The position factor is the relation between the user unit and the internal position unit (counts). The position factor is automatically calculated when the feed constant (Object 6092h) and gear ratio (Object 6091h) are set.

Example:

We have a MAC motor with a 3.5:1 gear box connected to a belt drive. The diameter of the drive wheel is 12.4 cm. We want the unit of position to be in millimetres.

The circumference of the drive wheel is 389.56mm (124mm\*pi). The parameters should be set as follows:

Object	Name	Value
6091h subindex 1	Gear_ratio_Motor_revolutions	35
6091h subindex 2	Gear_ratio_Shaft_revolutions	10
6092h subindex 1	Feed_constant_Feed	38956
6092h subindex 2	Feed_constant_Shaft_revolutions	100

Please note that it is not necessary to set the encoder resolution. This is automatically set by the module.

Positions\_factor formula:

$$\text{Position\_factor} = \frac{\text{Gear\_ratio\_Motor\_rev.} * \text{Feed\_constant\_Shaft\_Rev.} * \text{Position\_encoder\_res.} * \text{Encoder\_Increments}}{\text{Feed\_constant\_Feed} * \text{Feed\_constant\_Shaft\_rev.} * \text{Position\_encoder\_res.} * \text{Motor\_rev.}}$$

or as and object:

$$\text{Position\_factor} = \frac{\text{Object 6091sub1} * \text{Object 6092sub2} * \text{Object 608Fsub1}}{\text{Object 6092sub1} * \text{Object 6092sub2} * \text{Object 608Fsub2}}$$

The Position\_factor is calculated to in the above example:

$$\text{Position\_factor} = \frac{35 * 100 * 4096}{38956 * 10 * 1} = 36,8$$

Only for a MAC50-141 !. For an MAC800, the resolution 4096 must be changed to 8000 and for MAC400, 402, 1500 and MAC3000 the resolution is 8192.

#### Velocity\_encoder\_factor. (2) in section 4.3.39.

This factor is used to convert the user unit into the internal unit (counts/sec).

The factor is adjusted via object 6094h.

Example 1:

We have a MAC800 motor with 8000 counts/revolution. We want the user unit of the velocity to be in RPM. The parameters should be set as follows:

Object	Name	Value
6094h subindex 1	Velocity_encoder_factor_Numerator	8000
6094h subindex 2	Velocity_encoder_factor_Divisor	60

## 4.6 Expansion Mod. MAC00-FC2/FC4/FC41

Velocity\_encoder\_factor formula:

$$\text{Velocity\_encoder\_factor} = \frac{\text{Velocity\_encoder\_factor\_Numerator}}{\text{Velocity\_encoder\_factor\_Divisor}} * \frac{16}{\text{SampleFreq}}$$

notice that the samplefrequens is differens in MAC050-141.

Or as and object:

$$\text{Velocity\_encoder\_factor} = \frac{\text{Object 6094sub1}}{\text{Object 6094sub2}} * \frac{16}{\text{Samplefreq}}$$

The Velocity\_encoder\_factor in example 1 is calculated to:

$$\text{Velocity\_encoder\_factor} = \frac{8000}{60} * \frac{16}{770} = 2,77 \text{ RPM}$$

Example 2:

We have a MAC800 motor with 8000 counts/revolution and the same belt drive as in the above example under Position\_Factor. We want the user unit of the velocity to be in mm/s. The parameters should be set as follows:

Object	Name	Calculated value	Value
6094h subindex 1	Velocity_Encoder_Factor_Numerator	$389.56/(3.5*8000)$ =0.013913	13913
6094h subindex 2	Velocity_Encoder_Factor_Divisor	1	1000000

The Velocity\_encoder\_factor in example 2 is calculated to:

$$\text{Velocity\_encoder\_factor} = \frac{13913}{1000000} * \frac{16}{770} = 0,000289 \text{ mm}$$

### Acceleration\_factor. (3) in section 4.3.39.

This factor is used to convert the user unit into the internal unit (counts/sec<sup>2</sup>). The factor is adjusted via object 6097h.

Example 1:

We have a MAC800 motor with 8000 counts/revolution. We want the user unit of the acceleration to be in RPM/s. The parameters should be set as follows:

Object	Name	Value
6097h subindex 1	Acceleration_factor_Numerator	8000
6097h subindex 2	Acceleration_factor_Divisor	60

Acceleration\_factor formula:

$$\text{Acceleration\_factor} = \frac{\text{Acceleration\_factor\_Numerator}}{\text{Acceleration\_factor\_Divisor}} * \frac{16}{\text{SampleFreq} * \text{SampleFreq}}$$

## 4.6 Expansion Mod. MAC00-FC2/FC4/FC41

Or as and object:

$$\text{Acceleration\_factor} = \frac{\text{Object 6097sub1}}{\text{Object 6097sub2}} * \frac{16}{\text{Samplefreq} * \text{Samplefreq}}$$

notice that the samplefrequens is differens in MAC050-141.

The Acceleration\_factor in example 1 is calculated to:

$$\text{Accelerationr\_factor} = \frac{8000}{60} * \frac{16}{770 * 770} = 0,003598 \text{ RPM/s}$$

Example 2:

We have a MAC800 with 8000 counts/rev. and the same belt drive as in the above example under Position\_Factor. We want the user unit of the acceleration to be in mm/s<sup>2</sup>. The parameters should be set as follows:

Object	Name	Calculated value	Value
6097h subindex 1	Acceleration_Encoder_Factor_Numerator	389.56/(3.5*8000) =0.013913	13913
6097h subindex 2	Acceleration_Encoder_Factor_Divisor	1	1000000

The Acceleration\_factor in example 2 is calculated to:

$$\text{Accelerationr\_factor} = \frac{13913}{1000000} * \frac{16}{770 * 770} = 3,75 * 10^{-7} \text{ mm/s}^2$$

### Feed\_constant\_factor. (4) in section 4.3.39.

Feed\_constant\_factor formula:

$$\text{Feed\_constant\_factor} = \frac{\text{Feed\_constat\_Feed}}{\text{Feed\_constant\_Shaft\_revolutions}}$$

or as and object:

$$\text{Feed\_constant\_factor} = \frac{\text{Object 6092sub1}}{\text{Object 6092sub2}}$$

### Position\_factor\_Numerator (5) in section 4.3.39.

Position\_factor\_Numerator formula

$$\text{Position\_factor\_Numerator} = \frac{\text{Feed\_constant\_Feed} * \text{Position\_factor}}{\text{Feed\_constant\_Shaft\_revolutions}}$$

or as and object:

$$\text{Position\_factor\_Numerator} = \frac{\text{Object 6092sub1} * \text{Position\_factor}}{\text{Object 6092sub2}}$$

## 4.6 Expansion Mod. MAC00-FC2/FC4/FC41

---

### Digital Inputs (6) in section 4.3.39.

Bits 31: 24 The Motor Status register (2011-3)  
Bits 23: 16 HardwareInputs (2011-1) - the 6 HW-inputs on the module  
Bit 2: Home sensor state  
Bits 1: 0  
Bits 5: 4 from (HardwareInputs ANDed with InputSetup (2011-7)) - (in reality in puts 5 and 6)  
DitallInputs= ((UINT32)Inputs<<16)  
((UINT32)MotorStatus<<24  
(((Inputs & InputSetup)>>4) & 0x3)  
(unsigned char)P5\_P0<<2

### Outputs (7) in section 4.3.39.

Outputs=((DigitalOutputs & OutputMask)>>16) & 0x3

Note that the module outputs come from the manufacturer specific bits 17:16 and that bit 0, Set Brake, is not implemented.

### Home offset (8) in section 4.3.39.

P\_Home=-(PositionFactor\*HomeOffset)+HomeTable[Method].HomeOffset\*IndexDistance\*UseIndex

#### 4.6.48 Changing operation mode

A change of operation mode is only possible when the operation mode is not enabled. There are two exceptions and one is when changing from homing mode to profile position mode. This is possible when the homing sequence is completed and can be done even though the operation mode is enabled. The other exception is when changing from profile position mode into velocity mode.

#### 4.6.49 Profile position mode

This mode can be used for positioning where a movement profile can be set up. The acceleration and maximum velocity can be programmed.

In this mode, both absolute and relative moves are supported. The type of move is selected via bit 6 (abs/rel) in the status word. When a relative move is selected, the type of relative move is dependent on the setup in object 2011h subindex 8.

It is also possible to select different movement modes. This is done using bit 5 (change set immediately) in the status word. When this bit is 0 and a move is in progress, the new set-point is accepted. But the new set-point and profile are not activated before the previous movement is finished. When this bit is 1, the new set-point is activated instantly and the motor will move to the new position with the new profile parameters.

Please note:

- The torque limit that is used during the profile can be set via object 6072h.
- The register L1 (object 2012 subindex 81) is used to select the load factor when the profile is started. If a different load factor is required, this register must be set correctly.



## 4.6 Expansion Mod. MAC00-FC2/FC4/FC41

---

### 4.6.50 Velocity mode

In this mode the motor runs at a selected velocity. A new velocity can be selected and the motor will then accelerate/decelerate to this velocity.

The maximum slippage error is not supported in this mode.

Please note:

- The torque limit can be set via object 6072h.

### 4.6.51 Homing mode

In this mode different homing sequences can be initiated. The standard homing modes from section 4.3.22 are supported.

The home sensor must be connected to the AIN input on the module.

If the end limit inputs must be active during the homing sequence, they must be enabled via object 2011h subindex 7.

The sensors should be connected to the appropriate inputs NL and PL.

The torque limit used during homing is selected via object 2100h. The unit of this is object is the same as other torque objects, e.g. Object 6072h.

There are also 4 manufacturer specific methods. These are listed in the table below.

Method	Uses index	Description
-1	Yes	Torque homing in negative direction and afterwards homing on the index pulse.
-2	Yes	Torque homing in positive direction and afterwards homing on the index pulse.
-3	No	Torque homing in negative direction.
-4	No	Torque homing in positive direction.

Please note that you should always use a home offset (object 607Ch) when using torque homing. This is to ensure that the motor moves away from the end limit. The sign of the home offset should be the opposite of the homing direction. For example, when using a negative homing direction, the home offset could be 5000.

## 4.6 Expansion Mod. MAC00-FC2/FC4/FC41

### 4.6.52 Supported PDOs

Receive PDOs

PDO no.	Mapping object index	Mapping object name	Comment
1	6040h	Controlword	Controls the state machine
2	6040h 6060h	Modes of operation	Controls the state machine and modes of operation
3	6040h 607Ah	Controlword Target position (pp)	Controls the state machine and the target position (pp)
4	6040h 60FFh	Controlword Target velocity (pv)	Controls the state machine and the target velocity (pv)
7	6040h 60FEh	Controlword Digital outputs	Controls the state machine and the digital outputs

Transmit PDOs

PDO no.	Mapping object index	Mapping object name	Event driven	Comment
1	6041h	Statusword	Yes	Shows status
2	6041h 6061h	Modes of operation	Yes	Shows status and the current mode of operation
3	6041h 6064h	Statusword Position actual value	No	Shows status and the current position (pp)
4	6041h 606Ch	Statusword Velocity actual value	No	Shows status and the current velocity (pv)
7	6041h 60FDh	Statusword Digital inputs	Yes	Controls the state machine and the digital inputs

## 4.6 Expansion Mod. MAC00-FC2/FC4/FC41

### 4.6.53 CANopen® DS-301 device profiles

Standardized devices in CANopen® have their characteristics described in a device profile. For each device profile, particular data and parameters are strictly defined, data and parameters are known as objects in CANopen. Objects perform all processes in CANopen®, they can perform various tasks, it can be as a communication object or as device specific objects, where they are directly related to the device. A communication object can transport data to the bus control and establish connection, or supervise the network devices.

The application layer makes it possible to exchange meaningful real-time-data across the CAN network, the format of this data and its meaning must be known by the producer and the consumer(s). There are encoding rules that define the representation of values of data types and the CAN network transfer syntax for the representations. Values are represented as bit sequences. Bit sequences are transferred in sequences of octets (byte). For numerical data types the encoding is with the lowest byte first.

Every object is described and classified in the object dictionary (or index) and is accessible through the network. They are addressed using a 16 bit index so that the object dictionary may contain a maximum of 65536 entries.

Index (Hex)	Object	Supported by MAC00-FCxx
0000-	Not used	
0001-001F	Static data types	
0020-003F	Complex data types	
0040-005F	Manufacturer specific Data Types	
0060-0FFF	Reserved for further use	
1000-1FFF	Communication Profile area DS301	Yes
2000-5FFF	Manufacturer specific profile area	Yes
6000-9FFF	Standardised Device Profile area (DSP-402)	Yes
A000-FFFF	Reserved for further use	

#### Index 0001-001F:

Static data types contain type definitions for standard data types like boolean, integer, floating point etc. These entries are included for reference only, they cannot be read or written.

#### Index 0020-003F:

Complex data types are pre-defined structures that are composed out of standard data types and are common to all devices.

#### Index 0040-005F:

Manufacturer specific data types are also structures composed of standard data types but are specific to a particular device.

#### Index 1000-1FFF:

The communication Profile area contains the parameters for the communication profile on the CAN network. These entries are common to all devices.

#### Index 2000-5FFF:

The manufacturer specific profile area, for truly manufacturer specific functionality.

## 4.6 Expansion Mod. MAC00-FC2/FC4/FC41

Index 6000-9FFF:

The standardised device profile area, contains all data objects common to a class of devices that can be read or written via the network. The drives profile uses entries from 6000h to 9FFFh to describe the drive parameter and the drive functionality. Within this range up to 8 devices can be described. In such a case the device are denominated Multi Device Modules. Multi Device Module are composed of up to 8 device profile segments. By this feature it is possible to build devices with multiple functionality. The different device profile entries are shifted with 800h.

A 16-bit index is used to address all entries within the object dictionary. In case of a simple variable this references the value of this variable directly. In case of records and arrays however, the index addresses the whole data structure. To allow individual elements of structures of data to be accessed via the network a sub-index has been defined. For single object dictionary entries such as and Unsigned8, Boolean, Integer32, the value for the sub-index is always zero. For complex object dictionary entries such as arrays or records with multiple data fields the sub-index refers to fields within a data-structure pointed to by the main index. Index counting starts with one.

The DS-301 standard is the application and the communications profile for a CANopen® bus, and is the interface between the devices and the CAN bus. It defines the standard for common data and parameter exchange between other bus devices, and it controls and monitors the devices in the network. In the table below are listed some of the communications profile objects:

Data Transfer	Parameter Transfer	Special functions	
PDO			Process Data Objects
	SDO		Service Data Objects
		SYNC	Synchronisation
		EMCY	Emergency

The access from the CAN network is done through data objects PDO (Process Data Object) and SDO (Service Data Object).

### 4.6.54 Boot up telegram

After the initialization phase, a CANopen® slave log on with a boot up message. The node address of the slave is contained in this. This allows a CANopen® master to know which slaves are connected to the network. The protocol uses the same identifier as the error control protocols, see the figure below:

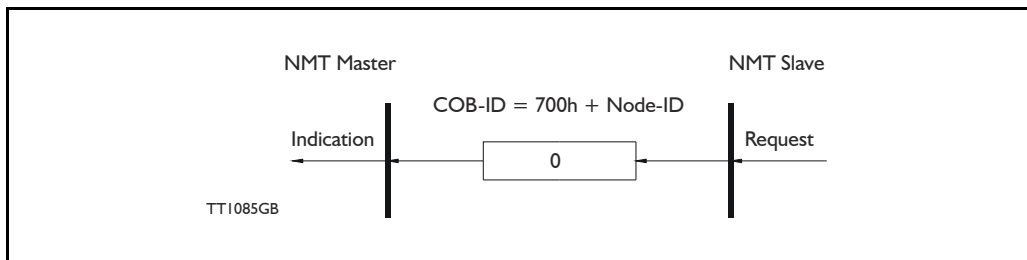

One data byte is transmitted with value 0.

## 4.6 Expansion Mod. MAC00-FC2/FC4/FC41

### 4.6.55 PDO (Process Data Object):

PDO: Performs real time transfers, and the transfer of PDOs are performed without a protocol. PDOs are used in two ways, for data transmission and for data reception. PDOs can bundle all objects from the object data directory, and a PDO can handle max 8 bytes of data in the same PDO. The PDO can consist of multiple objects. Other PDOs characteristic is, that it doesn't reply when it is receiving data, this for making the data transfer fast. It has a high priority identifier.

PDO connections follow the Producer/Consumer model. Whereby a normal PDO connection follows the Push model and a RTR connection the Pull model.

Objects are mapped in a PDO. This mapping is an agreement between the sender and receiver as to which object is located at which position in the PDO. This means that the sender knows at which position in the PDO it should write data and the receiver knows to where it should transfer data which it received.

The PDOs correspond to entries in the Device Object Dictionary and provide the interface to the application objects. Data type and mapping of application objects into a PDO is determined by a corresponding PDO mapping structure within the Device object Dictionary. Number and length of PDOs of a device is application specific and have to be specified within the device profile

Write PDO service:

The Write PDO service is unacknowledged. There is a PDO producer which sends its PDO to the PDO consumer. There can be 0 or more consumers in the network. For receive PDOs, MAC00-FCxx is the consumer and for Transmit PDOs, the producer. The following figure shows a Write PDO service:

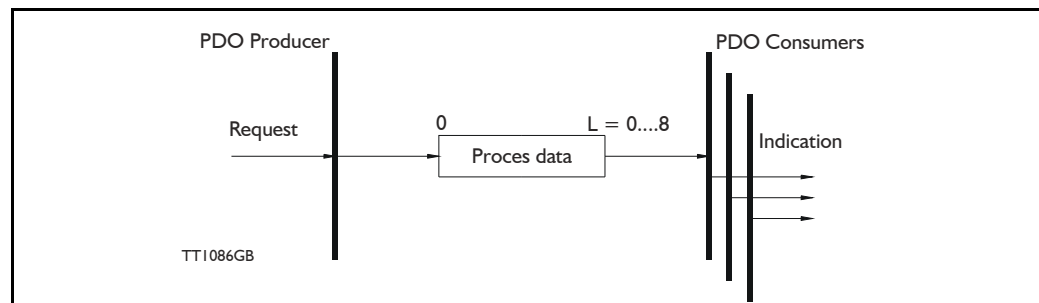

Read PDO service:

The read PDO service is an acknowledged service. One of the several PDO consumers send a RTR message to the network. After it has received the RTR message, the PDO producer sends the requested PDO. This service is used for RTR queries. Using this service, an actual value can be interrogated independently of the selected cycle time. The following figure show a read PDO service:

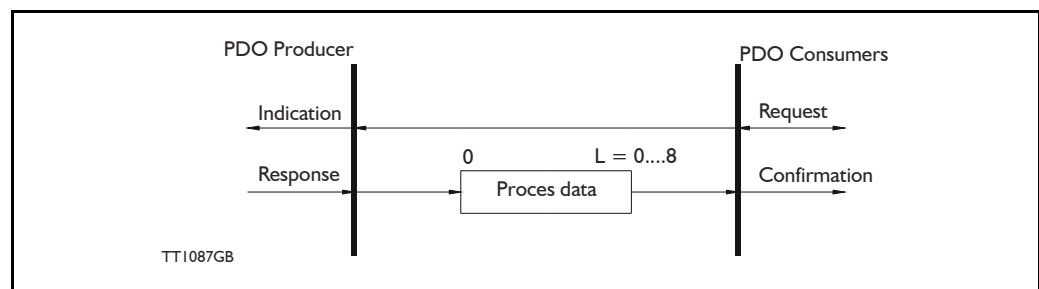

## 4.6 Expansion Mod. MAC00-FC2/FC4/FC41

PDO identifier:

In the CANOpen® profile it is only possible to have four transmit and four receive PDOs enabled at the same time. In the MAC00-FCxx all PDOs are disabled when the module is booted up, the user has to choose which PDOs the application is to use, and enable these.

The PDO configuration can be seen either in the EDS-file or in the CanOpen Explorer program, here the communication and the mapping parameter are shown.

There are two standard methods to map the PDOs in CAN-Open, there is a static mapping and a dynamic mapping. In the static PDO mapping all PDOs are mapped in accordance with some fixed non-modifiable setting in the relevant PDO. In the dynamic PDO mapping the setting for a PDO can be modified. It is also allowed to have flexible combination of different process data during operation. The MAC00-FCxx module, use only static mapping.

### 4.6.56 SDO (Service Data Objects):

SDO: can access all entries in the object directory, but they are normally used in the initialization, during the boot up procedure. Some SDOs characteristic are:

- Confirmed transfer of objects
- Data transfer/exchange is always non-synchronous
- Values greater than 4 bytes are transferred (Normal transfer)
- Values not more than 4 bytes are transferred (Expedited transfer)

Basically a SDO is transferred as a sequence of segments. Prior to transferring the segment there is an initialization phase where client and server prepare themselves for transferring the segment. For SDOs, it is also possible to transfer a data set of up to four bytes during the initialisation phase. This mechanism is called an expedited transfer.

Down loading SDO protocol

The download SDO protocol is used to write the values of the object directory into the drive

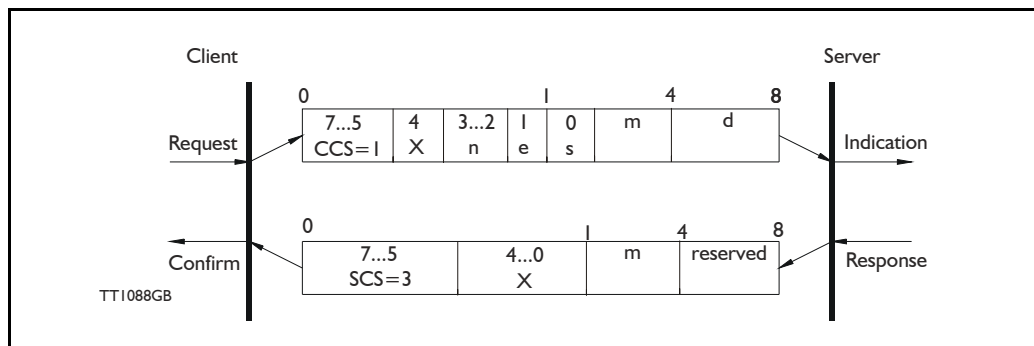

## 4.6 Expansion Mod. MAC00-FC2/FC4/FC41

### Upload SDO protocol

The upload SDO protocol is used to read the values in the object directory of the drive.

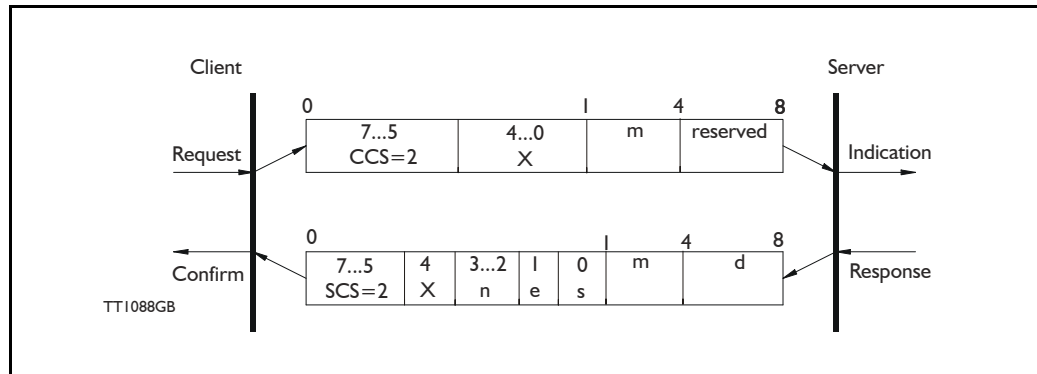

Table for upload and download SDO protocol.

	<b>CCS:</b>	<b>SCS:</b>	<b>n:</b>	<b>e:</b>	<b>s:</b>	<b>m:</b>
Down-load	1: Initiate down-load request	3: Initiate download response	Only valid if e=1 and s=1 otherwise 0. If valid it indicates the number of bytes in d that do not contain data. Bytes [8-n,7] do not contain data	Transfer type: 0= normal transfer 1= expedited transfer	Size indicator: 0=data set size is not indicated 1=data set size is indicated	Multiplexer. It represents the index/sub-index of the data to be transfer by the SDO
Upload	2: Initiate upload request	2: Initiate upload response	Only valid if e=1 and s=1 otherwise 0. If valid it indicates the number of bytes in d that do not contain data. Bytes [8-n,7] do not contain data	Transfer type: 0= normal transfer 1= expedited transfer	Size indicator: 0=data set size is not indicated 1=data set size is indicated	Multiplexer. It represents the index/sub-index of the data to be transfer by the SDO

CCS:Client command specified.

SCS:Server commander specified.

## 4.6 Expansion Mod. MAC00-FC2/FC4/FC41

Table for upload and download SDO protocol (continued)

	<b>d:</b>	<b>X:</b>	<b>Reserved:</b>
Download	<b>e=0, s=0:</b> d is reserved for further use <b>e=0, s=1:</b> d contains the number of bytes to be downloaded. Byte 4 contain the lsb and byte 7 contain the msb <b>e=1, s=1:</b> d contain the data of length 4-n to be downloaded, the encoding depends on the type of the data reference by index and sub-index.	not used, always 0	Reserved for further use, always 0
Upload	<b>e=0, s=0:</b> d is reserved for further use <b>e=0, s=1:</b> d contains the number of bytes to be uploaded. Byte 4 contain the lsb and byte 7 contain the msb <b>e=1, s=1:</b> d contain the data of length 4-n to be uploaded, the encoding depends on the type of the data reference by index and sub-index.	not used, always 0	Reserved for further use, always 0

Abort SDO transfer protocol:

SDO tasks, which the MAC00-FCxx cannot process are responded to using an abort SDO protocol. If the module does not respond in the expected time, the CANOpen® master also sends an abort SDO.

The following figure show a abort SDO transfer protocol:

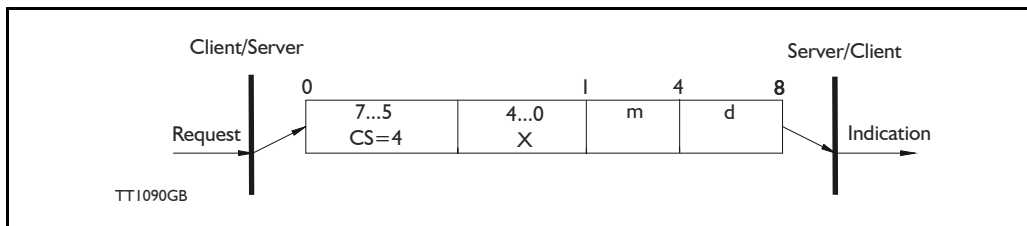

There are various abort codes in CANopen®, these are listed in the table below:

<b>Abort code</b>	<b>Description</b>
0503 0000h	Toggle bit not alternated
0504 0000h	SDO Protocol timed out
0504 0001h	Client/server command specified not valid or unknown
0504 0002h	Invalid block size (block mode only)
0504 0003h	Invalid sequence number (block mode only)
0504 0004h	CRC error (block mode only)
0504 0005h	Out of memory
0601 0000h	Unsupported access to an object
0601 0001h	Attempt to read a write only object
0601 0002h	attempt to write a read only object
0602 0000h	Object does not exist in the object dictionary
0604 0041h	Object cannot be mapped to the PDO

Table continued on next page.



## 4.6 Expansion Mod. MAC00-FC2/FC4/FC41

Address table continued from previous page:

Abort code	Description
0604 0042h	The number and length of the objects to be mapped would exceed PDO length
0604 0043h	General parameter incompatibility reason
0606 0000h	Access failed due to an hardware error
0607 0010h	Data type does not match, length of service parameter does not match
0607 0012h	Data type does not match, length of service parameter too high
0607 0013h	Data type does not match, length of service parameter too low
0609 0011h	Sub-index does not exist
0609 0030h	Value range of parameter exceeded (only for write access)
0609 0031h	Value of parameter written too high
0609 0032h	Value of parameter written too low
0609 0036h	Maximum value is less than minimum value
0800 0000h	General error
0800 0020h	Data cannot be transferred or stored to the application
0800 0021h	Data cannot be transferred or stored to the application because of local control
0800 0022h	Data cannot be transferred or stored to the application because of the present device state
0800 0023h	Object dictionary dynamic generation fails or no object dictionary is present (e.g. object dictionary is generated from file and generation fails because of a file error).

### 4.6.57 SYNC (Synchronisation Object)

A SYNC producer sends the synchronization object cyclically a broadcast telegram. The SYNC telegram defines the basic clock cycle of the network. The time between the SYNC telegram is set using the object Communication Cycle period (1006h). In order to obtain a precise (accurate) cycle between the SYNC signals, the SYNC telegram is sent with a high-priority identifier. This can be modified using the object (1005h). The SYNC transfer applies the producer/consumer push model and is non-confirmed.

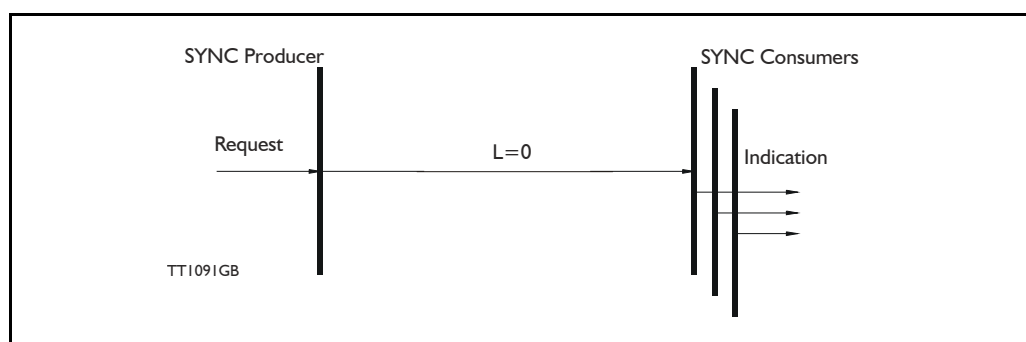

The SYNC does not carry any data (L=0). The identifier of the SYNC object is located at object 1005h.

## 4.6 Expansion Mod. MAC00-FC2/FC4/FC41

### 4.6.58 NMT (Network Management services)

The Network Management is structured according to nodes and follows a master-slave structure. NMT objects are used for executing NMT services. Through NMT services, nodes are initialised started, monitored, resetted or stopped. All nodes are regarded as NMT slaves. An NMT slave is uniquely identified in the network by its Node-ID. NMT requires that one device in the network fulfils the function of the NMT master. The NMT master controls the state of the NMT slaves. The state attribute is one of the values (Stopped, Pre-operational, Operational, initialising). The module control services can be performed with a certain node or with all nodes simultaneously. The NMT master controls its own NMT state machine via local services, which are implementation dependent. The Module Control Service except Start Remote Node can be initiated by the local application.

A general NMT protocol:

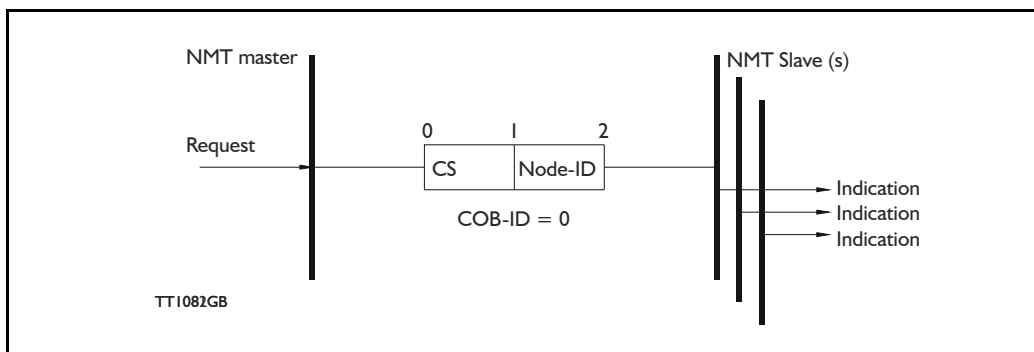

Where **CS** is the NMT command specified. The Node-ID of the NMT slave as assigned by the NMT master in the Node Connect protocol, or 0. If 0, the protocol addresses all NMT slaves.

CS =	Operation
1	Start Remote Node
2	Stop Remote Node
128	Enter Pre Operational
129	Reset Node
130	Reset Communication

**Start Remote Node:**

This is an instruction to transition from the Pre-Operational to Operational communications state. The drive can only send and receive process data when it is in the Operational state.

**Stop Remote Node:**

This is an instruction to transition from Pre-Operational into stopped or from Operational into Stopped. In the stopped state, the nodes can only process NMT instructions.

**Enter Pre Operational:**

This is an instruction to transition from Operational or Stopped into Pre-Operational. In the Pre-Operational state, the node cannot process any PDOs. However, it can be parameterized or operated via SDO. This means setpoint can also be entered.

## 4.6 Expansion Mod. MAC00-FC2/FC4/FC41

---

### Reset Node:

This is an instruction to transition from Operational, Pre-Operational or Stopped to initialization. After the Reset Node instruction, all objects (1000h-9FFFh) are reset into the Voltage On stage.

### Reset Communication:

This is an instruction to transition from Operational or Stopped to Initialization. After the Reset Communication instruction, all communication objects (1000h-1FFFh) are reset into the initial state.

In the various communication states, nodes can only be accessed via CANOpen® using specific communication services. Further, the nodes in the various states only send specific telegram. This is clearly shown in the following table:

	Initializing	Pre-Operational	Operational	Stopped
PDO			X	
SDO		X	X	
Synchronization Object		X	X	
Emergency Object		X	X	
Boot-Up Object	X			
Network Management object		X	X	X

### 4.6.59 Error Control Services

There exist two possibilities to perform Error Control:

- Node Guarding/Life Guarding
- Heartbeat

With Node Guarding, the CANOpen® master sends, to each slave an RTR telegram (Remote Transmit request) with the COB-ID 1792 (700h) + node-ID.

The slave responds, with the same COB-ID, with its communications state. This means either Pre-Operational, Operational or stopped.

The CANOpen® slave also monitors the incoming RTR telegram from the master.

The cycle of the incoming RTR telegrams is set by using the Guard Time Object.

The numbers of RTR telegrams which can fail as a maximum before the slave initiates a Life Guarding event is defined using the Life time factor object.

The Node Life Time is calculated from the product of the Guard Time and Life Time Factor. This is the maximum time which the slave waits for an RTR telegram.

## 4.6 Expansion Mod. MAC00-FC2/FC4/FC41

The figure below show a Node Guarding/Life Guarding protocols

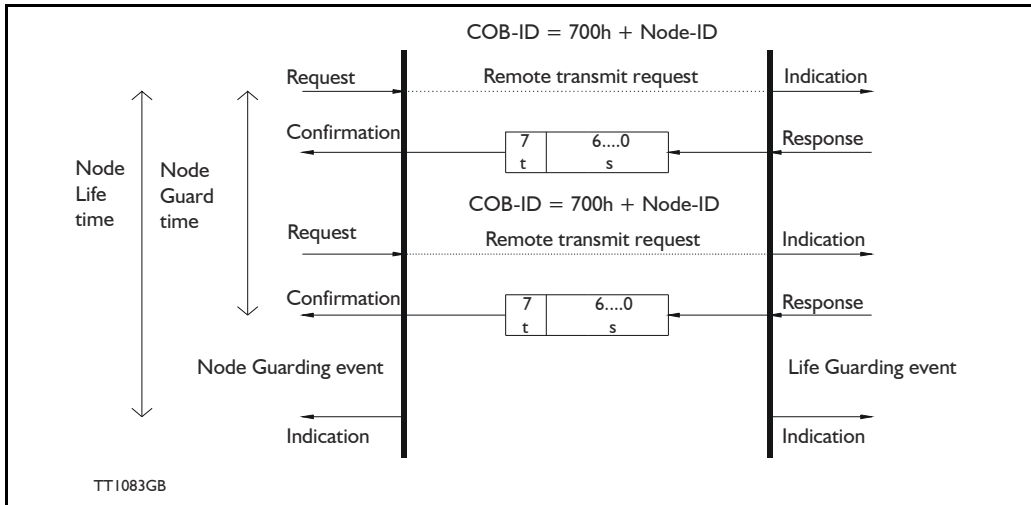

Where s is the state of the NMT slave:

s	NMT state
4	Stopped
5	Operational
7	Pre-operational

t: is the toggle bit, it alternate between 2 consecutive responses from the NMT Slave. The value of the toggle-bit of the first response after the guarding protocol becomes active, is 0. The Toggle Bit in the guarding protocol is only reset to 0 when the NMT message Reset Communication is passed (no other change of state resets the toggle bit). If a response is received with the same value of the toggle-bit as in the preceding response then the new response is handled as if it was not received.

Heartbeat:

With the Heartbeat protocol, a Heartbeat Producer cyclically sends its communications state to the CAN bus. One or more Heartbeat Consumers receive the indication. The relationship between producer and consumer is configured via the object dictionary. The Heartbeat Consumer guards the reception of the Heartbeat within the Heartbeat Consumer time. If the Heartbeat is not received within the Heartbeat Consumer Time a Heartbeat Event will be generated.

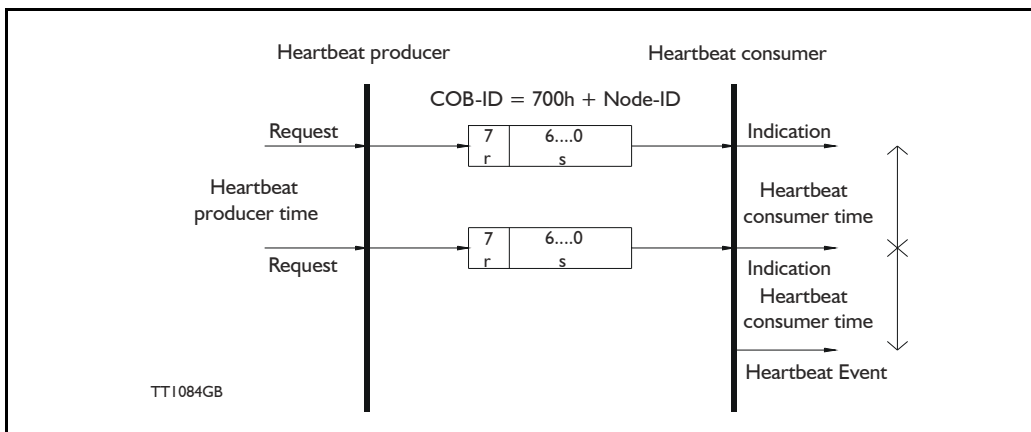

## 4.6 Expansion Mod. MAC00-FC2/FC4/FC41

---

Where r is reserved (always 0).

s: is the state of the Heartbeat producer:

s	NMT state
0	Boot up
4	Stopped
5	Operational
7	Pre-operational

Only one communication monitoring service may be activated. This is either Node Guarding/Life Guarding or Heartbeat. If the Heartbeat Producer Time is configured on a device the Heartbeat Protocol begins immediately. If a device starts with a value for the Heartbeat Producer Time different from 0 the Heartbeat Protocol starts on the state transition from Initialising to Pre-operational. In this case the Boot-up Message is regarded as first heartbeat message. If the Heartbeat producer time is not 0 the heartbeat protocol is used.

In MAC00-FCxx none of the error control is enabled then the modules are started up, because if there is any fault in the system it is impossible to get in contact with the module. After the module has started up and there is communication between the master and the slave, then turn on the wanted error control mechanism in the object Dictionary, see section 4.4.20.

## 4.6 Expansion Mod. MAC00-FC2/FC4/FC41

CAN bus connectors - continued.

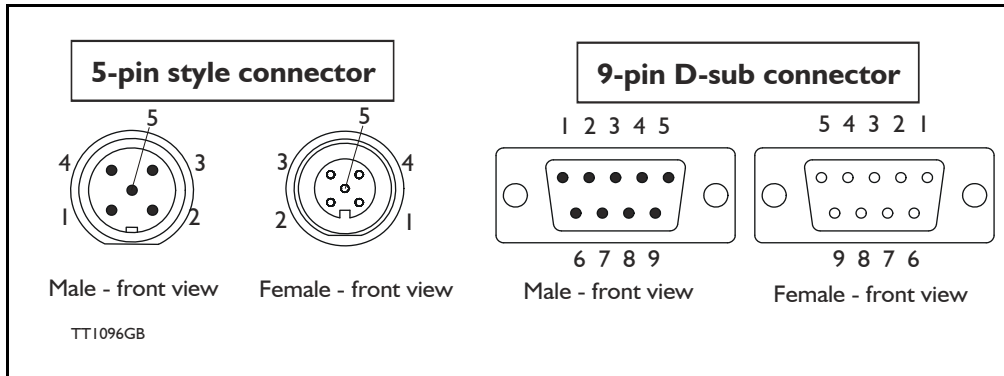

### 4.6.60 MAC00-FC2 Connectors

Rear plate layout:

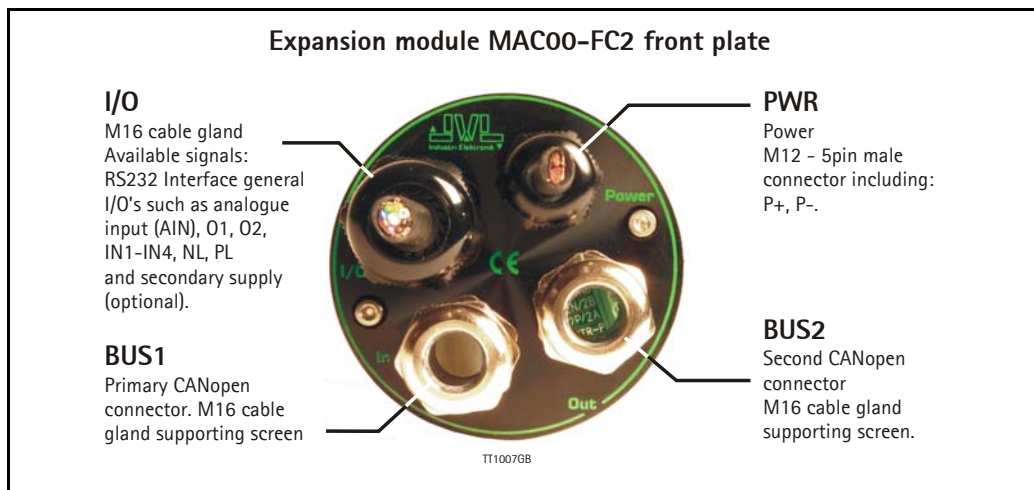

The MAC00-FC2 module is function as node in the CAN bus network, and the following terminals are available : B+ and A- are “Bus in”, and B+ and A- are “Bus out”. The connectors are placed on the dismantled module as the figure show below:

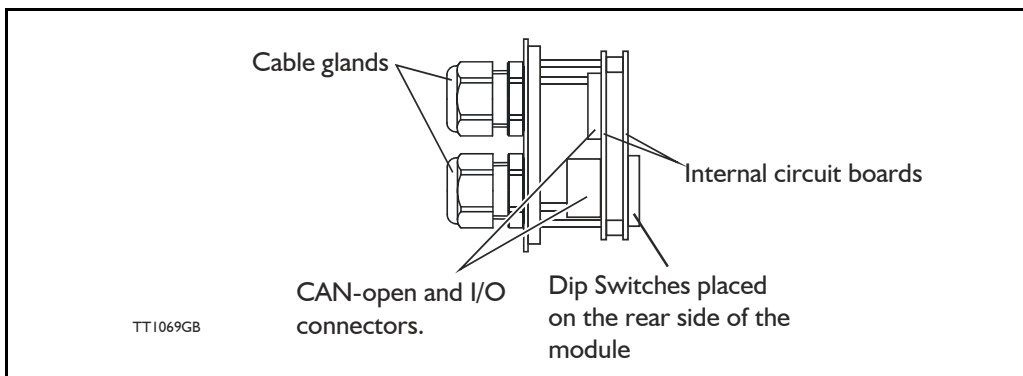

## 4.6 Expansion Mod. MAC00-FC2/FC4/FC41

The illustration below shows all the internal connectors in the module. The CAN bus and power connectors are easy-to-use screw terminals. If the I/Os are used, they require a JVL cable type WG0402 (2m), WG0410 (10m) or WG0420 (20m). See also the appendix for cable and connector accessories.

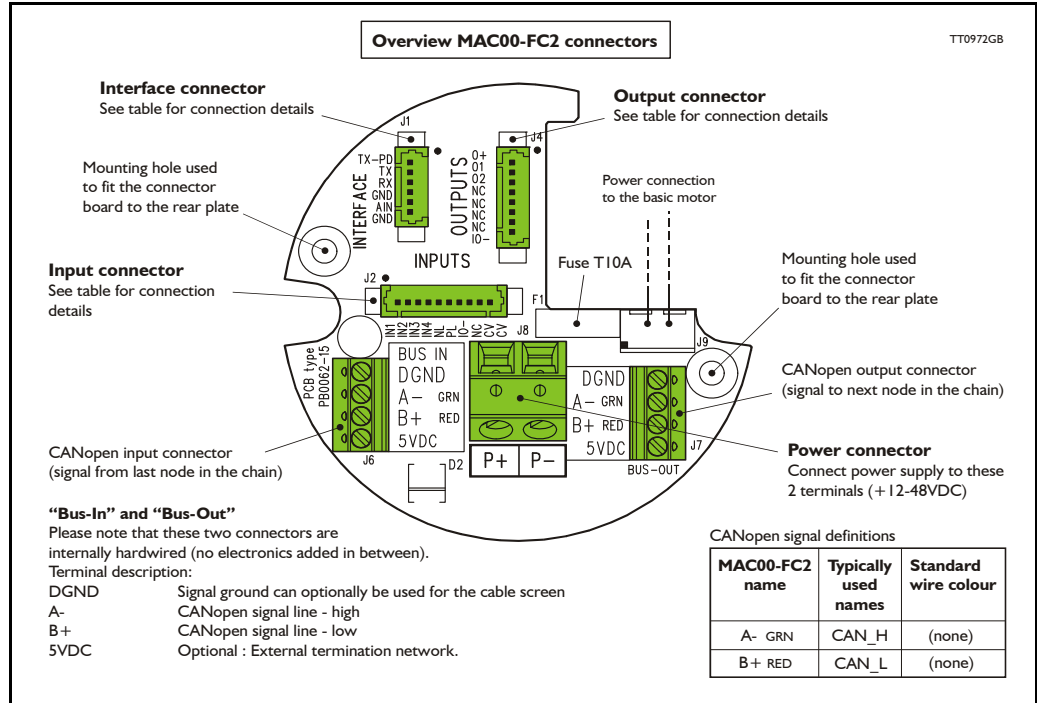

The MAC00-FC2 type number only covers the basic module, i.e. without any cables.

## 4.6 Expansion Mod. MAC00-FC2/FC4/FC41

### 4.6.61 MAC00-FC2 with cables (optional)

If a number is added after the basic type number, for example MAC00-FC2-10, this suffix indicates that the module is fitted with 10 m of cable in the I/O. The I/O cable covers all the signal lines, i.e. RS232, Digital input 1-4, Limit inputs NL and PL and the Digital outputs 1-4

<b>Digital Inputs - Internal connector J2</b>			
Signal name	Pin no.	Description	Wire colour
IN1	1	Digital input 1	Red/black
IN2	2	Digital input 2	Green/black
IN3	3	Digital input 3	Violet
IN4	4	Digital input 4	Violet/white
NL	5	Negative limit input - If not used, do not connect.	Grey
PL	6	Positive limit input - If not used, do not connect.	Grey/black
IO-	7	I/O ground. This ground is shared with the output ground	Pink/black
NC	8	(Reserved)	Black/white
CV	9	Secondary supply. Used during emergency stop	Light green **
CV	10	Secondary supply. Used during emergency stop	White
<b>Digital Outputs - Internal connector J4</b>			
Signal name	Pin no.	Description	Wire colour
O+	1	Supply for outputs - Must be connected to an ext. supply.	Red/white
O1	2	Digital output 1 - PNP output	Green/white
O2	3	Digital output 2 - PNP output	Yellow/black
NC	4	(Reserved)	Blue/white
NC	5	(Reserved)	Orange/white
NC	6	(Reserved)	Brown/white
NC	7	(Reserved)	Pink
IO-	8	I/O ground. This ground is shared with the input ground	Black
<b>Interface - including analogue input - Internal connector J1</b>			
Signal name	Pin no.	Description	Wire colour
TXPD	1	Transmit pull-down (Connect to TX if addr. not used).	Red
TX	2	RS232 Transmit (Connect to TXPD if addr. not used).	Green **
RX	3	RS232 Receive	Yellow
GND	4	Ground for RS232	Blue
AIN	5	Analogue input +/-10V or Zero sensor input	Orange
GND	6	Ground for AIN	Brown
<b>Cable Screen</b>			
The cable-screen is internally connected to motor housing. Externally it must be connected to earth.			
<b>Unused wire</b>			
Orange/Black - is not used internally. It must be left unconnected.			

\*\* : The light green wire (CV) can be difficult to distinguish from the green wire (TX) on some cables.



## 4.6 Expansion Mod. MAC00-FC2/FC4/FC41

### 4.6.62 MAC00-FC2 - How to connect the RS232 interface

This has to be done if MacTalk is used in the CAN-Open configuration. The illustration below shows how to connect the MAC00-FC2 directly to a PC COM port. The drawing is based on standard cables from JVL, type WG0402, WG0410 or WG0420. See also *Accessories, page 415* for a complete list of cables and connectors. If the MAC motor is connected to the same RS232 line as other motors, the terminal TX-PD should only be connected at one of the motors. If one of JVL's standard RS232 cables (RS232-9-1 or -n) is used between the DSUB connector shown and the PC com port, the RX and TX pins must be swapped since they cross in these standard cables.

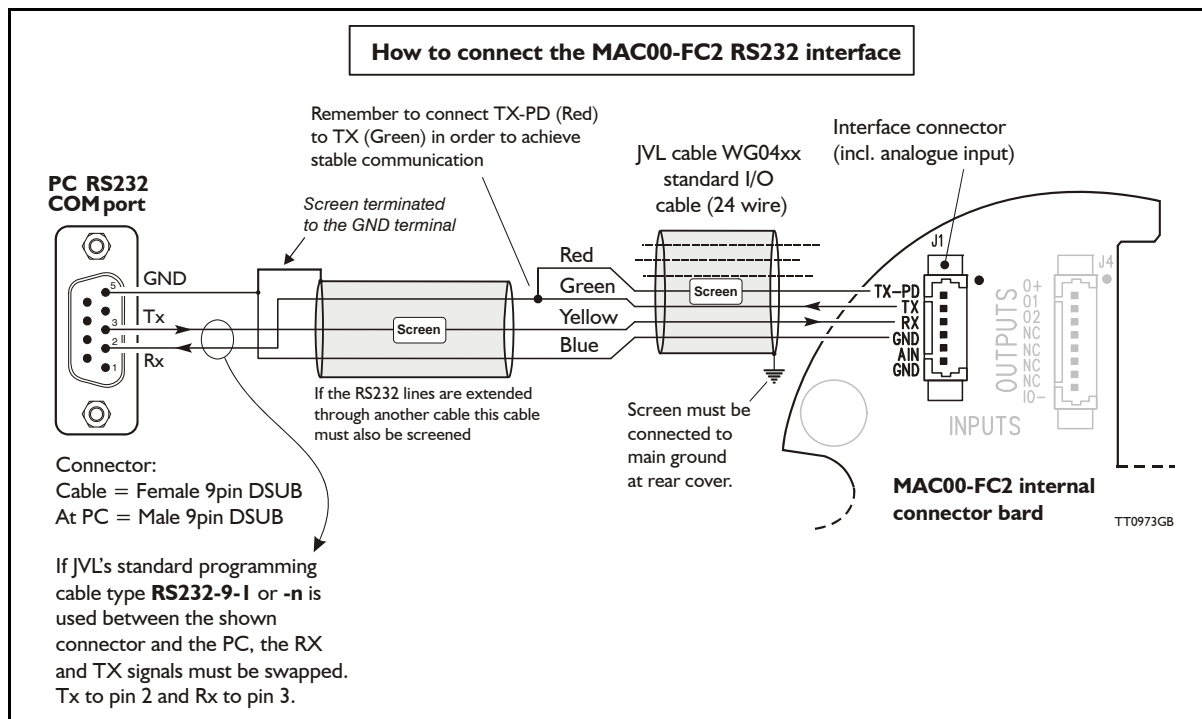

## 4.6 Expansion Mod. MAC00-FC2/FC4/FC41

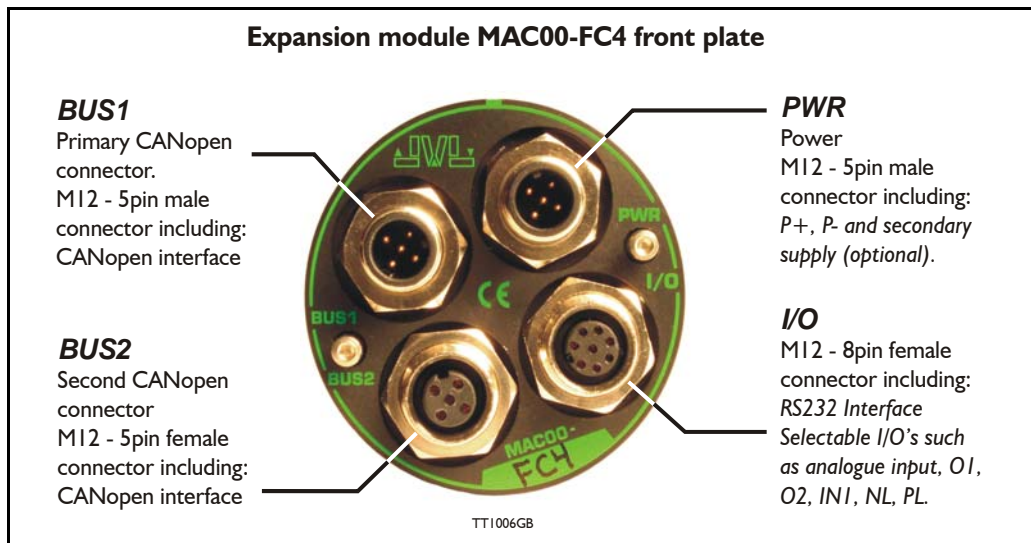

### 4.6.63 MAC00-FC4 connectors, rear plate layout

The set up of Baud-rate, Node-ID and terminator are selected in the same way as in the MAC00-FC2 module.

#### Expansion MAC00-FC4 Hardware description:

The MAC00-FC4 offers IP67 on MAC050-141 and IP65 on MAC400-800 protection and M12 connectors which makes it ideal for automation applications where no additional protection is desired. The M12 connectors offer solid mechanical protection and are easy to unplug compared to the FC2 module which has cable glands. The signals available are slightly restricted compared to the FC2 module since only 4 I/O terminals are available. The I/Os connected to these 4 terminals must be selected by a small dip-switch, see the drawing below the I/O table on the next page.

The connector layout:

<b>"PWR" - Power input. M12 - 5-pin male connector</b>				
Signal name	Description	Pin no.	JVL Cable W11000M12 F5T05N	Isolation group
P+	Main supply +12-48VDC. Connect with pin 2 * / **	1	Brown	1
P+	Main supply +12-48VDC. Connect with pin 1 * / **	2	White	1
P-	Main supply ground. Connect with pin 5 *	3	Blue	1
CV	Control voltage +12-48VDC / 12-30VDC **	4	Black	1
P-	Main supply ground. Connect with pin 3 *	5	Grey	1
* Note: P+ and P- is each available at 2 terminals. Make sure that both terminals are connected in order to split the supply current in 2 terminals and thereby avoid an overload of the connector. ** Note: When using MAC400 to 3000 the P+ and CV terminal can maximum be supplied by 12-30VDC.				
<b>"BUS1" - CAN-open interface. M12 - 5-pin male connector</b>				
Signal name	Description	Pin no.	Cable: W11006- M12F5SxxR	Isolation group
CAN_SHLD	Shield for the CAN interface - internally connected to the motor housing	1	Bare	2
CAN_V+	Reserved for future purpose - do not connect	2	Red	2
CAN_GND	CAN interface ground	3	Black	2
CAN_H	CAN interface. Positive signal line	4	White	2
CAN_L	CAN interface. Negative signal line	5	Blue	2

## 4.6 Expansion Mod. MAC00-FC2/FC4/FC41

<b>"BUS2" - CANopen® interface. M12 - 5-pin female connector</b>					
Signal name	Description	Pin no.	Cable: WI1006- M12M5SxxR	Isolation group	
CAN_SHLD	Shield for the CAN interface - internally connected to the motor housing	1	Bare	2	
CAN_V+	Reserved for future purpose - do not connect	2	Red	2	
CAN_GND	CAN interface ground	3	Black	2	
CAN_H	CAN interface. Positive signal line	4	White	2	
CAN_L	CAN interface. Negative signal line	5	Blue	2	
<b>"IO" - I/Os and RS232 interface. M12 - 8-pin female connector.</b>					
Signal name	Description	Function	Pin no.	JVL Cable WI1000-M12 M8T05N	Isolation group
IOC	I/O terminal C.	SW3 DIP 5 = OFF : <i>PL</i> input SW3 DIP 5 = ON : <i>O1</i> output	1	White	3
Tx	RS232 interface - transmit output Important !: DIP1 must be turned ON. If addressing is used it must be turned ON at minimum one of the connected motors.		2	Brown	1
Rx	RS232 interface - receive input		3	Green	1
GND	RS232 Ground - also used with analogue input		4	Yellow	1
IOA	I/O terminal A.	SW3 DIP 2 = ON and DIP3 = OFF : <i>A/N</i> (Analogue input) SW3 DIP2 = OFF and DIP 3 = ON : <i>O2</i> (output 2) ( <i>A/N</i> is the analogue input. Remember to use the GND terminal with <i>A/N</i> !).	5	Grey	3 (1 when used as <i>A/N</i> )
IOB	I/O terminal B.	SW3 DIP 4 = OFF : <i>IN1</i> (input 1) SW3 DIP 4 = ON : <i>O1</i> (output 1)	6	Pink	3
IO-	I/O ground to be used with <i>IN1</i> , <i>NL</i> , <i>PL</i> , <i>O1</i> , <i>O2</i>		7	Blue	3
IOD	I/O terminal D.	SW3 DIP 6 = OFF : <i>NL</i> (negative limit input) SW3 DIP 6 = ON : <i>O+</i> (output supply)	8	Red	3
<b>Cable Screen</b>					
Some standard cables with M12 connector offer a screen around the cable. This screen on some cables is fitted to the outer metal at the M12 connector. When fitted to the MAC00-FC4 module, this means that the screen will have contact with the complete motor housing and thereby also the power ground (main ground).					
<b>Isolation groups</b>					
The MAC00-FC4 offers optical isolation at the digital inputs and outputs ( <i>IN1</i> , <i>NL</i> , <i>PL</i> and <i>O1-2</i> ). The table shows a number for each pin. This number refers to the isolation group to which each pin is connected. Isolation group 1 means that the terminal refers to the main ground ( <i>P-</i> , <i>GND</i> and the motor housing). Isolation group 2 means that the terminal refers to the CAN interface ground ( <i>CAN_GND</i> ). Isolation group 3 means that the terminal refers to the I/O ground ( <i>IO-</i> )					

Regarding the setting of SW3, see on next page.

## 4.6 Expansion Mod. MAC00-FC2/FC4/FC41

The drawing below shows the SW3 Dip-switch location. The various settings of SW3 is shown on the previous page.

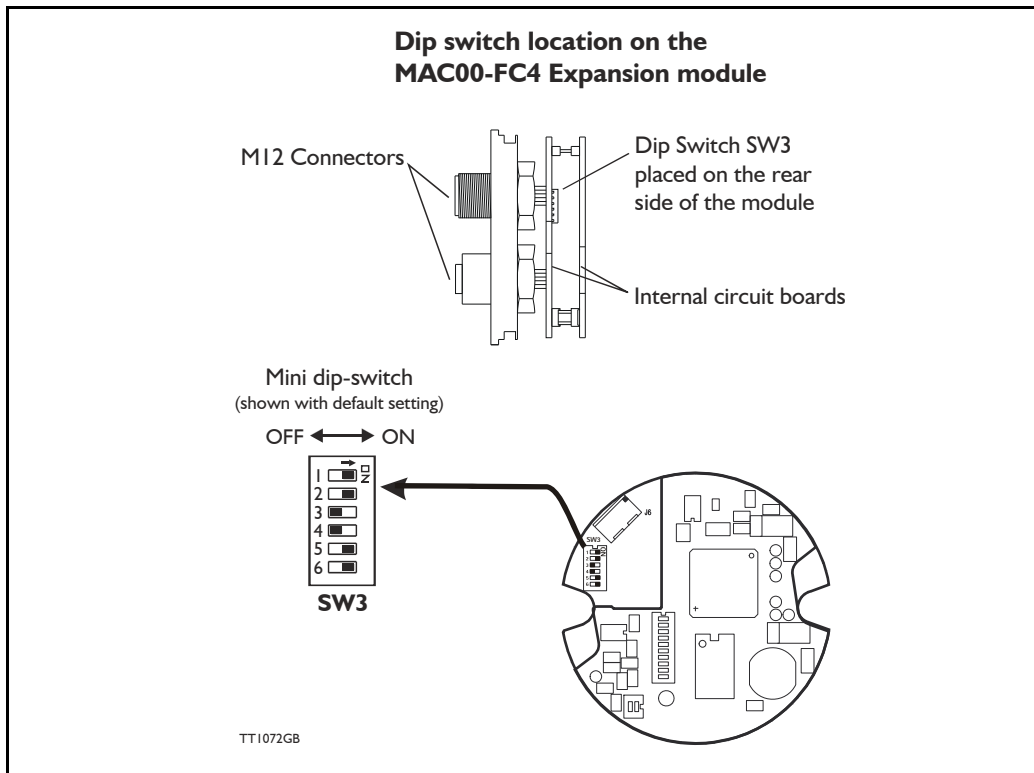

Switch description:

SW3	Description	Function	Signal name
Dip 1	RS232 interface - transmit output	ON = Enable	Tx
Dip 2 Dip 3	I/O terminal A	DIP2=ON and DIP3=OFF : AIN (Analogue input)	IOA
Dip 2 Dip 3	I/O terminal A	DIP2=OFF and DIP3=ON : O2 (output 2)	IOA
Dip 4	I/O terminal B	DIP4=ON : Output 1 DIP4=OFF : Input 1	IOB
Dip 5	I/O terminal C	DIP5=ON : O1 output DIP5=OFF : PL (positive limit input)	IOC
Dip 6	I/O terminal D	DIP6=ON : O+ (Output supply) DIP6=OFF : NL (Negative limit input)	IOD









The factory default setting is:

SW3	ON	OFF	Function
Dip 1	X		RS232 interface Enable
Dip 2 Dip 3	X	X	O2 (output 2)
Dip 4		X	Input 1
Dip 5	X		O1 output
Dip 6	X		O+ (output supply)

## 4.6 Expansion Mod. MAC00-FC2/FC4/FC41

### 4.6.64 Cables for the MAC00-FC4

The following cables equipped with M12 connector can be supplied by JVL.

MAC00-FC4 Connectors				Description	JVL Order no.	Photo
"BUS1" 5-pin Male B-cod- ed	"BUS2" 5-pin Female B-cod- ed	"I/O" 8-pin Fe- male	"PWR" 5-pin Male			
		X		RS232 Interface cable. Connects directly from MAC00-FC4 to PC Length: 5m (197 inch)	RS232-M12-1-5-8	
			X	Cable (Ø5.5mm) with M12 female 5-pin connector loose wire ends 0.35mm² (22AWG) and foil screen. Length: 5m (197 inch)	WI1000-M12F5T05N	
			X	Same as above but 20m (787 inch)	WI1000-M12F5T20N	
		X		Cable with M12 male 8-pin connector loose wire ends 0.22mm² (24AWG) and screen. Length: 5m (197 inch)	WI1000-M12M8T05N	
		X		Same as above but 20m (787 inch)	WI1000-M12M8T20N	
	X			CANopen® cable with M12 male 5-pin connector, loose ends and screen. Length: 5m (197 inch).	WI1006-M12M5S05R	
	X			Same as above but 15m (591 inch)	WI1006-M12M5S15R	
X				CANopen® cable with M12 female 5-pin connector, loose ends and screen. Length: 5m (197 inch)	WI1006-M12F5S05R	
X				Same as above but 15m (591 inch)	WI1006-M12F5S15R	
<b>Termination resistor</b>						
	X			CANopen® male M12 termination resistor.	WI1008-M12M5STR4	
<b>Protection caps. Optional if connector is not used, to protect from dust / liquids.</b>						
	X	X		IP67 protection cap for M12 female connector.	WI1000-M12FCAP1	
X			X	IP67 protection cap for M12 male connector.	WI1000-M12MCAP1	

**Important:** Please note that the cables are a standard type. They are not recommended for use in cable chains or where the cable is repeatedly bent. If this is required, use a special robot cable (2D or 3D cable). See also *Accessories*, page 4/5 where additional M12 connectors are shown.

## 4.6 Expansion Mod. MAC00-FC2/FC4/FC41

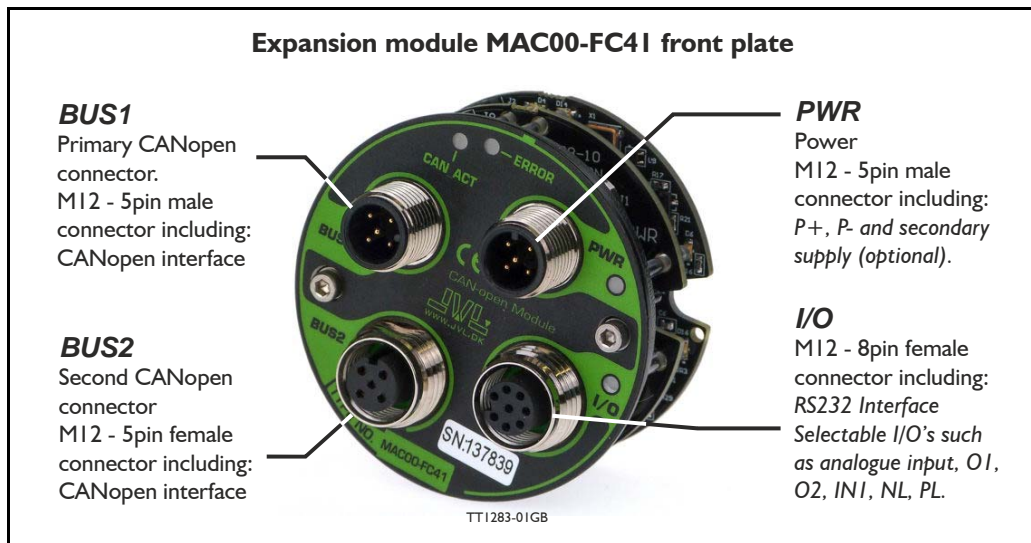

### 4.6.65 MAC00-FC41 connectors, rear plate layout

The set up of Baud-rate, Node-ID and terminator are selected in the same way as in the MAC00-FC2 module.

#### Expansion MAC00-FC41 Hardware description:

The MAC00-FC4 offers IP67 on MAC050-141 and IP65 on MAC400-800 protection and M12 connectors which makes it ideal for automation applications where no additional protection is desired. The M12 connectors offer solid mechanical protection and are easy to unplug compared to the FC2 module which has cable glands. The signals available are slightly restricted compared to the FC2 module since only 4 I/O terminals are available. The I/Os connected to these 4 terminals must be selected by a small dip-switch, see the drawing below the I/O table on the next page.

The connector layout:

<b>"PWR" - Power input. M12 - 5-pin male connector</b>				
Signal name	Description	Pin no.	JVL Cable W1100M12 F5T05N	Isolation group
P+	Main supply +12-48VDC. Connect with pin 2 * / **	1	Brown	1
P+	Main supply +12-48VDC. Connect with pin 1 * / **	2	White	1
P-	Main supply ground. Connect with pin 5 *	3	Blue	1
CV	Control voltage +12-48VDC / 12-30VDC **	4	Black	1
P-	Main supply ground. Connect with pin 3 *	5	Grey	1
* Note: P+ and P- is each available at 2 terminals. Make sure that both terminals are connected in order to split the supply current in 2 terminals and thereby avoid an overload of the connector. ** Note: When using MAC400 to 3000 the P+ and CV terminal can maximum be supplied by 12-30VDC.				
<b>"BUS1" - CAN-open interface. M12 - 5-pin male connector</b>				
Signal name	Description	Pin no.	Cable: W11006-M12F5SxxR	Isolation group
CAN_SHLD	Shield for the CAN interface - internally connected to the motor housing	1	Bare	2
CAN_V+	Reserved for future purpose - do not connect	2	Red	2
CAN_GND	CAN interface ground	3	Black	2
CAN_H	CAN interface. Positive signal line	4	White	2
CAN_L	CAN interface. Negative signal line	5	Blue	2

## 4.6 Expansion Mod. MAC00-FC2/FC4/FC41

<b>"BUS2" - CANopen® interface. M12 - 5-pin female connector</b>					
Signal name	Description	Pin no.	Cable: WI1006- M12M5SxxR	Isolation group	
CAN_SHLD	Shield for the CAN interface - internally connected to the motor housing	1	Bare	2	
CAN_V+	Reserved for future purpose - do not connect	2	Red	2	
CAN_GND	CAN interface ground	3	Black	2	
CAN_H	CAN interface. Positive signal line	4	White	2	
CAN_L	CAN interface. Negative signal line	5	Blue	2	
<b>"IO" - I/Os and RS232 interface. M12 - 8-pin female connector.</b>					
Signal name	Description	Function	Pin no.	JVL Cable WI1000-M12 M8T05N	Isolation group
IOC	I/O terminal C.	SW3 DIP 5 = OFF : <i>PL</i> input SW3 DIP 5 = ON : <i>O1</i> output	1	White	3
Tx	RS232 interface - transmit output Important !: DIP1 must be turned ON. If addressing is used it must be turned ON at minimum one of the connected motors.		2	Brown	1
Rx	RS232 interface - receive input		3	Green	1
GND	RS232 Ground - also used with analogue input		4	Yellow	1
IOA	I/O terminal A.	SW3 DIP 2 = ON and DIP3 = OFF : <i>AIN</i> (Analogue input) SW3 DIP2 = OFF and DIP 3 = ON : <i>O2</i> (output 2) ( <i>AIN</i> is the analogue input. Remember to use the GND terminal with <i>AIN</i> !).	5	Grey	3 (1 when used as <i>AIN</i> )
IOB	I/O terminal B.	SW3 DIP 4 = OFF : <i>IN1</i> (input 1) SW3 DIP 4 = ON : <i>O1</i> (output 1)	6	Pink	3
IO-	I/O ground to be used with <i>IN1</i> , <i>NL</i> , <i>PL</i> , <i>O1</i> , <i>O2</i>		7	Blue	3
IOD	I/O terminal D.	SW3 DIP 6 = OFF : <i>NL</i> (negative limit input) SW3 DIP 6 = ON : <i>O+</i> (output supply)	8	Red	3
<b>Cable Screen</b>					
Some standard cables with M12 connector offer a screen around the cable. This screen on some cables is fitted to the outer metal at the M12 connector. When fitted to the MAC00-FC4 module, this means that the screen will have contact with the complete motor housing and thereby also the power ground (main ground).					
<b>Isolation groups</b>					
The MAC00-FC4 offers optical isolation at the digital inputs and outputs ( <i>IN1</i> , <i>NL</i> , <i>PL</i> and <i>O1-2</i> ). The table shows a number for each pin. This number refers to the isolation group to which each pin is connected. Isolation group 1 means that the terminal refers to the main ground ( <i>P-</i> , <i>GND</i> and the motor housing). Isolation group 2 means that the terminal refers to the CAN interface ground ( <i>CAN_GND</i> ). Isolation group 3 means that the terminal refers to the I/O ground ( <i>IO-</i> )					

Regarding the setting of SW3, see on next page.

## 4.6 Expansion Mod. MAC00-FC2/FC4/FC41

The drawing below shows the SW3 Dip-switch location. The various settings of SW3 is shown on the previous page.

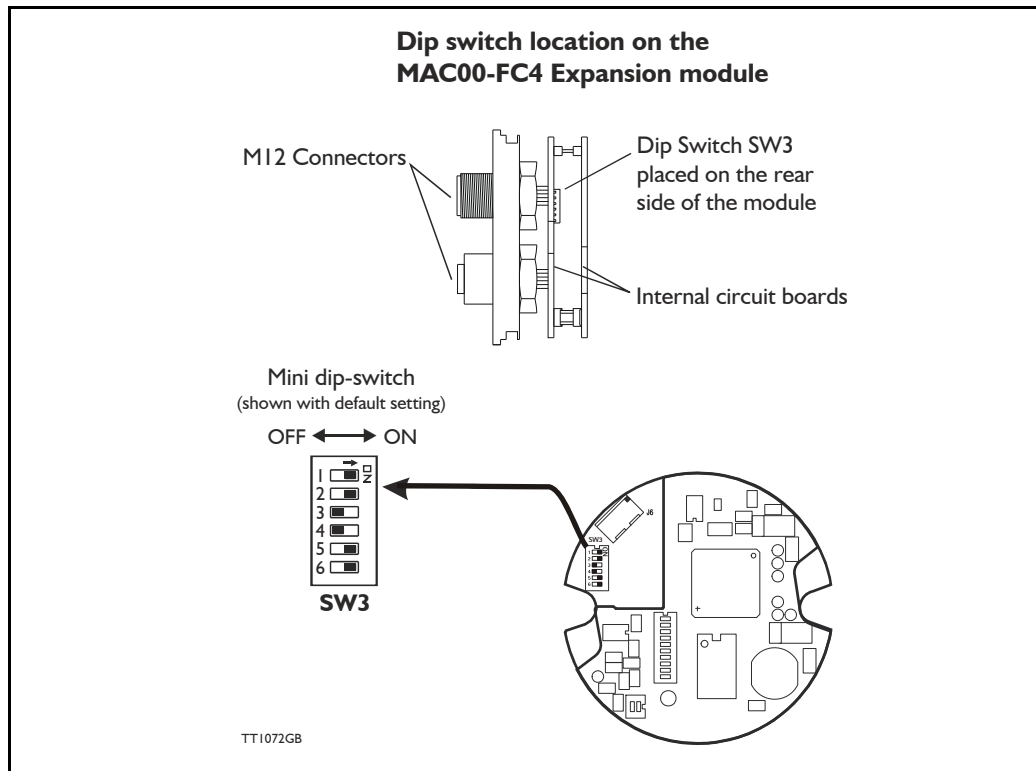

Switch description:

SW3	Description	Function	Signal name
Dip 1	RS232 interface - transmit output	ON = Enable	Tx
Dip 2 Dip 3	I/O terminal A	DIP2=ON and DIP3=OFF : AIN (Analogue input)	IOA
Dip 2 Dip 3	I/O terminal A	DIP2=OFF and DIP3=ON : O2 (output 2)	IOA
Dip 4	I/O terminal B	DIP4=ON : Output 1 DIP4=OFF : Input 1	IOB
Dip 5	I/O terminal C	DIP5=ON : O1 output DIP5=OFF : PL (positive limit input)	IOC
Dip 6	I/O terminal D	DIP6=ON : O+ (Output supply) DIP6=OFF : NL (Negative limit input)	IOD

The factory default setting is:









SW3	ON	OFF	Function
Dip 1	X		RS232 interface Enable
Dip 2 Dip 3	X	X	O2 (output 2)
Dip 4		X	Input 1
Dip 5	X		O1 output
Dip 6	X		O+ (output supply)



## 4.6 Expansion Mod. MAC00-FC2/FC4/FC41

### 4.6.66 Cables for the MAC00-FC41

The following cables equipped with M12 connector can be supplied by JVL.

MAC00-FC41 Connectors				Description	JVL Order no.	Photo
"BUS1" 5-pin Male B-cod- ed	"BUS2" 5-pin Female B-cod- ed	"I/O" 8-pin Fe- male	"PWR" 5-pin Male			
		X		RS232 Interface cable. Connects directly from MAC00-FC4 to PC Length: 5m (197 inch)	RS232-M12-1-5-8	
			X	Cable (Ø5.5mm) with M12 female 5-pin connector loose wire ends 0.35mm² (22AWG) and foil screen. Length: 5m (197 inch)	WI1000-M12F5T05N	
			X	Same as above but 20m (787 inch)	WI1000-M12F5T20N	
		X		Cable with M12 male 8-pin connector loose wire ends 0.22mm² (24AWG) and screen. Length: 5m (197 inch)	WI1000-M12M8T05N	
		X		Same as above but 20m (787 inch)	WI1000-M12M8T20N	
	X			CANopen® cable with M12 male 5-pin connector, loose ends and screen. Length: 5m (197 inch).	WI1006-M12M5S05R	
	X			Same as above but 15m (591 inch)	WI1006-M12M5S15R	
X				CANopen® cable with M12 female 5-pin connector, loose ends and screen. Length: 5m (197 inch)	WI1006-M12F5S05R	
X				Same as above but 15m (591 inch)	WI1006-M12F5S15R	
<b>Termination resistor</b>						
	X			CANopen® male M12 termination resistor.	WI1008-M12M5STR4	
<b>Protection caps. Optional if connector is not used, to protect from dust / liquids.</b>						
	X	X		IP67 protection cap for M12 female connector.	WI1000-M12FCAP1	
X			X	IP67 protection cap for M12 male connector.	WI1000-M12MCAP1	

**Important:** Please note that the cables are a standard type. They are not recommended for use in cable chains or where the cable is repeatedly bent. If this is required, use a special robot cable (2D or 3D cable). See also *Accessories*, page 415 where additional M12 connectors are shown.

## 4.7 Expansion Module MAC00-FD4



### 4.7.1 DeviceNet Introduction

The MAC00-FD4 module allows you to connect a JVL MacMotor to a DeviceNet network.

Using this module, all the registers in the MAC motor can be accessed over a DeviceNet network.

The module supports Baud-rates of 125, 250 and 500kbit. The module includes galvanic isolation between the motor and the DeviceNet network. The Baud-rate and node id must be configured via the internal dip switch before the module is connected to the network. The module supports polled IO with 8 bytes in and 8 bytes out.

The specification of the IO is according to the position controller device type.

#### Important:

Please refer to the following sections of the DeviceNet specifications for additional information:

- ① Volume II, Section 3-12: Position Controller.
- ② Volume II, Section 6-24: Position Controller Supervisor Object.
- ③ Volume II, Section 6-25: Position Controller Object.
- ④ Volume II, Section 6-14: Parameter Object.
- ⑤ Volume I, Appendix H: DeviceNet Error Codes
- ⑥ Volume I, Appendix J: Data Type Specification

The expansion module MAC00-FD4 can be mounted in standard MAC motors MAC50, MAC95, MAC140, MAC141, MAC400, MAC402, MAC800, MAC1500 and MAC3000.

The connectors are grouped as follows:

Type	Protection class	Connectors		
		I/O and interface	Power supply	Bus interface
MAC00-FD4	IP67/IP65*	M12	M12	M12 (x2)

Note\*: IP65 on MAC400-800

Cables with M12 connectors can be supplied for the MAC00-FD4 module.

The first part of this section deals with the software features of the module. Please see the later pages of this section for specific information about the hardware such as connection schemes etc.

## 4.7 Expansion Module MAC00-FD4

---

### 4.7.2 Terminology / Symantics

This chapter is ment to give an overall understanding of the fundamentals in terminology concerning the description of the MAC00-FD4 module.

#### **Numbering:**

All values are specified in decimal unless other is noted.

0x1234 or #1234 (omron format) specify a hexadecimal number.

#### **General terms:**

*Command message.*

A message sent from the master to the FD4 module describing a certain.

*IO-message.*

An IO-message is a bundle of 8 bytes sent to the MAC00-FD from the master in the system and visa versa.

*Register.*

A register is a physical memory location in the basic motor. All variables to be written or read a available as a register. For example the desired motor velocity can be set by writting to register 5. For a general motor register overview please consult *Mac-Talk communication, page 378*.

# 4.7 Expansion Module MAC00-FD4

## 4.7.3 Node-id, Baud-rate and Termination setup

The 10-way dip switch (SW1) is used to select the node ID and the Baud-rate. Switches 1-6 select the node ID, and switches 8-9 select the Baud-rate. The 2-way dip switch (SW2) is used to enable termination. When both switches are on, the termination is enabled.

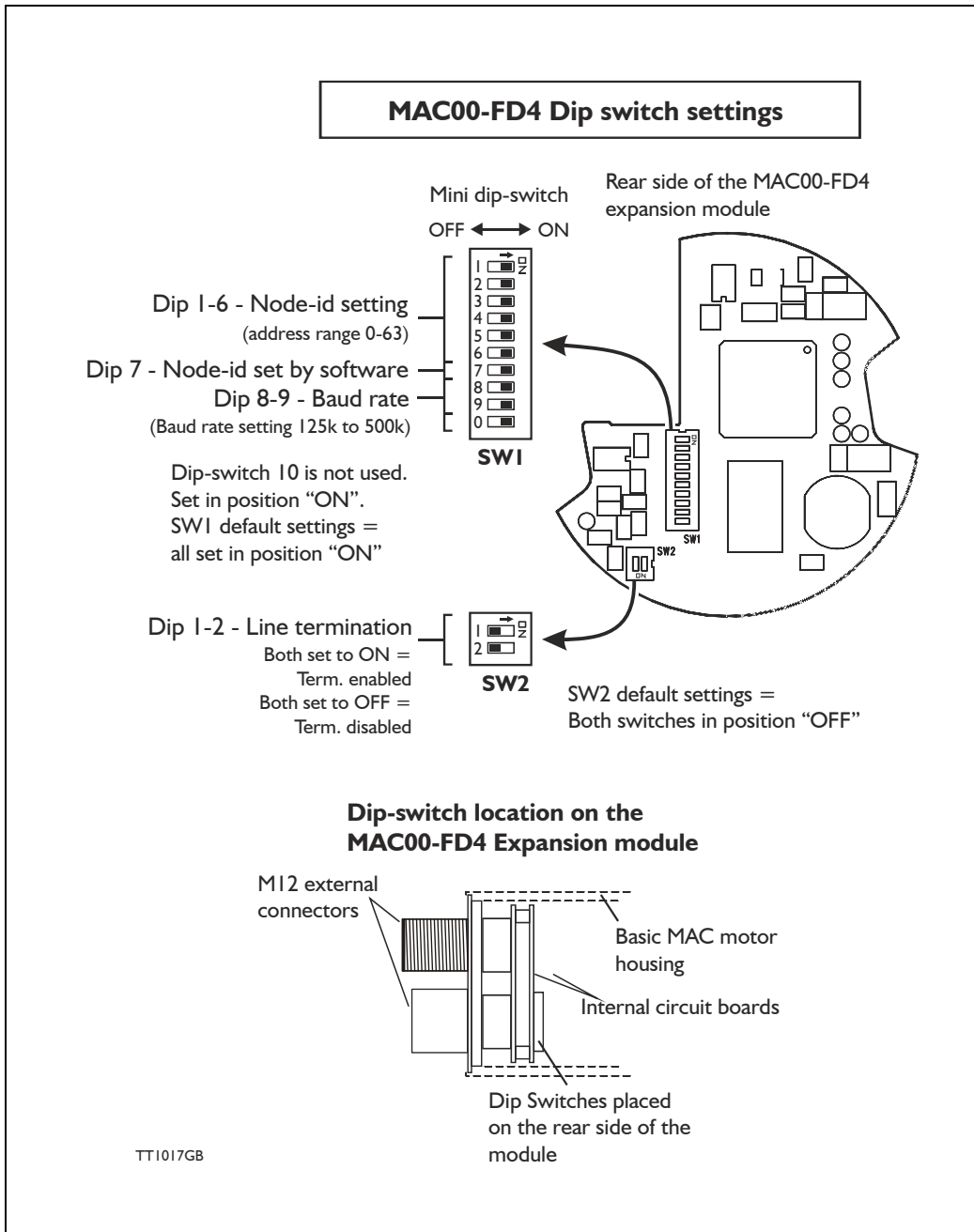

## 4.7 Expansion Module MAC00-FD4

The node-id can be set according to the below table:

Node-id	Dip Switch no. (SW1)						Node-id	Dip Switch no. (SW1)					
	6	5	4	3	2	1		6	5	4	3	2	1
0	Reserved (illegal setting)						32	ON	OFF	OFF	OFF	OFF	OFF
1	OFF	OFF	OFF	OFF	OFF	ON	33	ON	OFF	OFF	OFF	OFF	ON
2	OFF	OFF	OFF	OFF	ON	OFF	34	ON	OFF	OFF	OFF	ON	OFF
3	OFF	OFF	OFF	OFF	ON	ON	35	ON	OFF	OFF	OFF	ON	ON
4	OFF	OFF	OFF	ON	OFF	OFF	36	ON	OFF	OFF	ON	OFF	OFF
5	OFF	OFF	OFF	ON	OFF	ON	37	ON	OFF	OFF	ON	OFF	ON
6	OFF	OFF	OFF	ON	ON	OFF	38	ON	OFF	OFF	ON	ON	OFF
7	OFF	OFF	OFF	ON	ON	ON	39	ON	OFF	OFF	ON	ON	ON
8	OFF	OFF	ON	OFF	OFF	OFF	40	ON	OFF	ON	OFF	OFF	OFF
9	OFF	OFF	ON	OFF	OFF	ON	41	ON	OFF	ON	OFF	OFF	ON
10	OFF	OFF	ON	OFF	ON	OFF	42	ON	OFF	ON	OFF	ON	OFF
11	OFF	OFF	ON	OFF	ON	ON	43	ON	OFF	ON	OFF	ON	ON
12	OFF	OFF	ON	ON	OFF	OFF	44	ON	OFF	ON	ON	OFF	OFF
13	OFF	OFF	ON	ON	OFF	ON	45	ON	OFF	ON	ON	OFF	ON
14	OFF	OFF	ON	ON	ON	OFF	46	ON	OFF	ON	ON	ON	OFF
15	OFF	OFF	ON	ON	ON	ON	47	ON	OFF	ON	ON	ON	ON
16	OFF	ON	OFF	OFF	OFF	OFF	48	ON	ON	OFF	OFF	OFF	OFF
17	OFF	ON	OFF	OFF	OFF	ON	49	ON	ON	OFF	OFF	OFF	ON
18	OFF	ON	OFF	OFF	ON	OFF	50	ON	ON	OFF	OFF	ON	OFF
19	OFF	ON	OFF	OFF	ON	ON	51	ON	ON	OFF	OFF	ON	ON
20	OFF	ON	OFF	ON	OFF	OFF	52	ON	ON	OFF	ON	OFF	OFF
21	OFF	ON	OFF	ON	OFF	ON	53	ON	ON	OFF	ON	OFF	ON
22	OFF	ON	OFF	ON	ON	OFF	54	ON	ON	OFF	ON	ON	OFF
23	OFF	ON	OFF	ON	ON	ON	55	ON	ON	OFF	ON	ON	ON
24	OFF	ON	ON	OFF	OFF	OFF	56	ON	ON	ON	OFF	OFF	OFF
25	OFF	ON	ON	OFF	OFF	ON	57	ON	ON	ON	OFF	OFF	ON
26	OFF	ON	ON	OFF	ON	OFF	58	ON	ON	ON	OFF	ON	OFF
27	OFF	ON	ON	OFF	ON	ON	59	ON	ON	ON	OFF	ON	ON
28	OFF	ON	ON	ON	OFF	OFF	60	ON	ON	ON	ON	OFF	OFF
29	OFF	ON	ON	ON	OFF	ON	61	ON	ON	ON	ON	OFF	ON
30	OFF	ON	ON	ON	ON	OFF	62	ON	ON	ON	ON	ON	OFF
31	OFF	ON	ON	ON	ON	ON	63	ON	ON	ON	ON	ON	ON

## 4.7 Expansion Module MAC00-FD4

---

The Baud-rate can be set according to the below table:

Baud-rate	Dip Switch no. (SW1)				
	10	9	8	7	1-6
	X	OFF	OFF	X	See table above
125 kbit	X	OFF	ON	X	See table above
250 kbit	X	ON	OFF	X	See table above
500 kbit	X	ON	ON	X	See table above
Reserved	X	ON	ON	X	See table above

X = Not used. For future purposes - set in position off

## 4.7 Expansion Module MAC00-FD4

### 4.7.4 IO-messages.

The JVL MAC00-FD module offers 8 byte I/O.

These bytes are organized in a standard frame specified by the ODVA organisation. Depending on what kind of information that is needed different message types are used.

Message types are organized in the lower bit 0-4 in byte 2 and the different message types supported are:

0x1: "Target position"

0x2: "Target velocity"

0x3: "Acceleration"

0x5: "Torque"

0x1B: "Position controller attribute"

0x1F: "Parameter" (register)

For setting a target position the *Command Message type 0x1* is used. Accessing registers directly in the motor message type 0x1F is used. For a general motor register overview please consult *MacTalk communication, page 378*.

The outputs define a *Command message* covering the message types 0x1, 0x2, 0x3, 0x5 with the following format:

Byte	7	6	5	4	3	2	1	0
0	Enable	-	Hard stop	Smooth stop	Direction (vel. mode)	-	-	Load Data
1	0x1							
2	0x1			Command message type				
3	0x1			Response message type				
4	Data value byte 0							
5	Data Value byte 1							
6	Data Value byte 2							
7	Data Value byte 3							

Corresponding response frame from the motor is formatted in the following way.

The message frame for the types 0x1, 0x2, 0x3, 0x5.

Byte	7	6	5	4	3	2	1	0
0	Enable	-	Hard Stop	Smooth Stop	Direction (V. Mode)	-	-	Load data
1	0x1							
2	Load Complete	-	-	-	-	Reverse limit	Forward limit	-
3	0x1			Response Message Type				
4	Data value byte 0							
5	Data Value byte 1							
6	Data Value byte 2							
7	Data Value byte 3							

## 4.7 Expansion Module MAC00-FD4

The message frame for the type 0x1F is formatted according to the following:

Byte	7	6	5	4	3	2	1	0
0	Enable	-	Hard stop	Smooth stop	Direction (vel. mode)	-	-	Load Data
1	Register number to get							
2	0x1			Command message type				
3	Register number to set							
4	Data value byte 0							
5	Data Value byte 1							
6	Data Value byte 2							
7	Data Value byte 3							

The procedure is to setup the frame with the correct values and then set the "Load" -bit in byte 0 as the last operation. This will load the frame into the motor and thereby set the register value desired.

In response the motor will return a "Response" frame with the data from the register value that has been requested in the sent frame.

### Semantics:

**Load Data:** Transition from 0->1 initiates the data loading in the motor. The frame is setup with all data and then this bit is set to make the motor load the data.

**Direction:** When the motor is used in velocity mode this bit is used to control the direction of the movement. When velocity mode is used through

**Smooth stop:** Bring the motor to stop using standard configured deceleration (deceleration ramp is the same as the acceleration ramp).

**Hard stop:** Bring the motor to an immediate stop.

**Enable:** Bring the motor into an active mode clearing this bit will bring the motor into "Passive" -mode.



## 4.7 Expansion Module MAC00-FD4

The response frame from the motor is formatted as follows.

Byte	7	6	5	4	3	2	1	0
0	Enable	-	-	-	General fault	On Target position	-	Profile in progress
1	Register number to get							
2	Load Complete	-	-	-	-	Reverse limit	Forward limit	-
3	0x1			0x1F				
4	Data value byte 0							
5	Data Value byte 1							
6	Data Value byte 2							
7	Data Value byte 3							

### Semantics:

Load complete: Indicates that the motor has read the frame.

Reverse limit: By using limit switches to limit the travel distance of the motor this bit indicates that the motor encountered the reverse limit switch at the input.

Forward limit: By using limit switches to limit the travel distance of the motor this bit indicates that the motor encountered the forward limit switch at the input.

### 4.7.5 Object class 0x64.

Each instance has 2 attributes.

With this class all parameters in the motor can be written and read.

The instance number refers to the parameter number in the motor.

Attribute 1 = Value

Attribute 2 = Parameter size in bytes

## 4.7 Expansion Module MAC00-FD4

### 4.7.6 Object class 0x65

Instance 1 (I/O Setup)

Attribute ID	Access rule	Data type	Description	Parameter mapping
1	Get	USINT	The total number of supported attributes	-
2	-	-	Reserved	-
3	Get	BYTE	Show the input status. IN1-4, NL, PL	240 (0xF0)
4	Get/Set	BYTE	Set the output level	241 (0xF1)
5	Get/Set	BYTE	Input active level	242 (0xF2)
6	Get/Set	BYTE	Input setup	243 (0xF3)
7	Get/Set	BYTE	Output setup	244 (0xF4)

Instance 2 (Status)

Attribute ID	Access rule	Data type	Description	Parameter mapping
1	Get	USINT	The total number of supported attributes	-
2	-	-	Reserved	-
3	Get	BYTE	Motor status	245 (0xF5)

Instance 3 (Commands)

Attribute ID	Access rule	Data type	Description	Parameter mapping
1	Get	USINT	The total number of supported attributes	-
2	-	-	Reserved	-
3	Get/Set	BYTE	Module setup	246 (0xF6)
4	Set	USINT	Execute FastMac Command	247 (0xF7)
5	Set	USINT	MAC00-FDx command	248 (0xF8)

## 4.7 Expansion Module MAC00-FD4

### 4.7.7 Instance 1, Attribute 3, Input status

This object is used to read out the actual value of the inputs.

Bit	7	6	5	4	3	2	1	0
Input	Reserved		PL	NL	IN4	IN3	IN2	IN1

### 4.7.8 Instance 1, Attribute 4, Outputs

With this object the outputs can be controlled.

The value written to this object is directly shown on the outputs if the output is not set to use its default function (see attribute 7).

Bit	7	6	5	4	3	2	1	0
Output	Reserved						O2	O1

### 4.7.9 Instance 1, Attribute 5, Input active level

With this object the active level of the inputs can be selected. When bit  $x = 0$  the input is active low and when bit  $x = 1$  the input is active high.

The default setup for the output is active high.

Bit	7	6	5	4	3	2	1	0
Input	Reserved		PL	NL	IN4	IN3	IN2	IN1

### 4.7.10 Instance 1, Attribute 6, Input setup

With this object, the dedicated function of the inputs can be enabled. When the corresponding bit is 0 the input function is as a normal input. When the corresponding bit is 1 the dedicated function of the input will be enabled. When the end limit inputs NL or PL are enabled and one of these is activated, the error action will be executed. The error action is defined in instance 3, attribute 3.

Bit	7	6	5	4	3	2	1	0
Input	Reserved		PL	NL	Reserved			

### 4.7.11 Instance 1, Attribute 7, Output setup

This object is used to control the function of the outputs. When bit  $x = 0$  the output is controlled by attribute 4.

When bit  $x = 1$  the output is controlled by the default function. The default function for O1 is 'In position' and for O2 'Error'.

Bit	7	6	5	4	3	2	1	0
Output	Reserved						O2	O1

## 4.7 Expansion Module MAC00-FD4

### 4.7.12 Instance 2, Attribute 3, Motor status

With this object, the status of the motor can be monitored.

Bit	7	6	5	4	3	2	1	0
Data	-	Decele- ration	Accele- ration	In position	-	Limit switch error	Discon- nected	Motor error

Bit 7: Unused - reserved for future purposes.

Bit 6: Equals 1, if the velocity is decreasing.

Bit 5: Equals 1, if the velocity is increasing.

Bit 4: Equals 1, if the motor is in the commanded position.

Bit 3: Unused - reserved for future purposes.

Bit 2: Equals 1, if a limit switch has been activated.

Bit 1: Equals 1, if there is a communication error between the MAC00-FDx and the motor. This can occur if the motor was reset due to a voltage drop.

Bit 0: Equals 1, if there is a fatal motor error. Read subindex 4 for extended information.

### 4.7.13 Instance 3, Attribute 3, Module setup bits

This object is used for auxiliary setup of the module.

Bit	7	6	5	4	3	2	1	0
Setup	Endless relative	Error action	Reserved					

Endless relative: When this bit is 1, the endless relative position mode is used for incremental positioning. When using this mode, absolute positioning can no longer be used.

Error action: Determines the action in the event of an error. Bit6 set to 0 will set the motor in passive mode in case of an error, Bit6 set to 1 will stop motor by setting velocity to 0 in the event of an error.

### 4.7.14 Instance 3, Attribute 4, FastMac command

When writing to this attribute, a FastMac command is executed. Please refer to the MAC00-FPx section for a description of the FastMac commands.

### 4.7.15 Instance 3, Attribute 5, Module command

When writing to this attribute, it is possible to execute some special commands on the MAC00-FDx module.

The following commands are available:

Number	Function
0	No operation
1	Reset limit error
2	Reset communication error
3-255	Reserved

## 4.7 Expansion Module MAC00-FD4

---

### 4.7.16 Object class 0xF (Parameter)

This object class is the parameter class defined by the DeviceNet standard. The attributes that are mapped into this object are from object class 0x64 and 0x65. Instance 0-239 is mapped to the value attribute in object class 0x64 from the corresponding instance. Instance 240-255 is mapped to attributes from object class 0x65. Refer to the description of this object class for the mappings.

### 4.7.17 Object class 0x24 (Position Controller Supervisor)

This object class is the *Position controller supervisor object*, as defined in the DeviceNet standard.

The following class attributes are supported: 1,2,3,6,32,33.

The following attributes are supported for instance 1: 1,3,5,6,7.

### 4.7.18 Object class 0x25 (Position Controller)

This object class is the position controller object, as defined in the DeviceNet standard.

The following attributes are supported for instance 1:

1,2,3,6,7,8,10,11,12,13,14,17,20,21,25,45,48,49,52,54,55,58.

The range for attribute 25:Torque is 0-1023.

The following additional manufacturer-specific attributes are supported:

Attribute ID	Access rule	Data type	Description
100	Get/Set	USINT	Search mode. This mode will be used next time the controller is enabled and the selected mode is position. This value will be cleared after the enable.
101	Get/Set	DINT	The <i>Zero search</i> offset in counts
102	Get/Set	DINT	The velocity to use during <i>Zero search</i> in encoder counts per second.
103	Get/Set	DINT	The torque limit to use during <i>Zero search</i> . The range is -1023 to 1023. A negative torque value means that the zero sensor is active low.
104	Get/Set	BOOL	Use Index. If this is enabled, the zero point will be corrected with reference to the motors index mark.

## 4.7 Expansion Module MAC00-FD4

---

### 4.7.19 Examples - Typical needed actions in a DeviceNet system.

A number of typical actions is often needed in a system with DeviceNet interface to perform the desired operation in the system.

This chapter have some important guidelines on how to handle these typical actions and issues.

#### **Addressing registers in the motor using explicit messaging and I/O-messages.**

Although the basic positioning handling is done using the standard *Position controller* specified from the ODVA organisation it is sometimes necessary to access the registers directly. This section covers the various ways of doing this on top of a more thorough explanation on the different data formats. For a general motor register overview please consult *MacTalk communication, page 378*.

Register addressing in the motor:

To access the registers in the motor there are 2 ways of doing this. Either use explicit messages or the I/O message approach.

Explicit register access:

To access the registers in the motor explicit (not cyclic), use the object 0x64 with the instance number as a reference to the register number and the attribute as the amount of bytes that needs to be handled.

Example: The velocity of the motor needs to be set. In order to do this the velocity register (register 5 named "V\_SOLL") must be used.

To setup the explicit message, setup the following parameters as follows:

Object 0x64  
Instance: 5 (register 5, V\_SOLL register)  
Attribute 1: Data (for write operation)  
Attribute 2: Bytes (write operation)

I/O-message access (cyclic transmission):

To gain access to the motor registers directly using the I/O-message approach simply use the command message type 0x1F. Please see *IO-messages., page 230* in order to see details concerning the 0x1F message frame.

#### **JOG function.**

Often it is necessary to run the motor a certain distance in positive or negative direction in order to find a certain reference point or similar.

The MAC motor can be controlled in several different modes. Typically used modes are "Position" -mode for positioning purpose or "Velocity" -mode which control the motor movement without taking any notice of the actual position.

If a JOG function is needed it is strongly recommended to use the velocity mode since the position mode or related modes involves a number of registers and is more complex compared to the velocity mode.

In velocity mode, none of the position related registers are of particular interest but the actual position counter is still updated continuously.

## 4.7 Expansion Module MAC00-FD4

---

Performing the JOG function in velocity only requires that the velocity register (V\_SOLL - register 5) is used.

A way of implementing "JOG" -functionality is basically to change actual mode to "Velocity" and control the velocity and acceleration.

The following guideline can be used.

1. Set velocity = 0 (register 5), to avoid immediate movement when the mode is changed to velocity.
2. Change the mode to Velocity mode (register 2 = 1), now the mode is changed but the velocity is set to 0 so the motor stay stationary.
3. According to the direction, change the velocity to a positive value to run CW or negative to run CCW. Please remember that this value is scaled depending on the motor type used. The value is written into the velocity register (register 5 / V\_SOLL)  
MAC50-140 the scaling is [RPM] x 2.097, so 1000 RPM = 2097 [counts/smpl.]  
MAC400/402 the scaling is [RPM] x 2.837, so 1000 RPM = 2837 [counts/smpl.]  
MAC800 the scaling is [RPM] x 2.771, so 1000 RPM = 2771 [counts/smpl.]  
MAC1500 the scaling is [RPM] x 2.837, so 1000 RPM = 2837 [counts/smpl.]  
MAC3000 the scaling is [RPM] x 2.837, so 1000 RPM = 2837 [counts/smpl.]
4. To stop the motor set the velocity to 0. This will force the motor to decelerate and stay stationary keeping the actual position obtained after running with a velocity > 0.

Optional:

If the motor needs to be switched into a position related mode the actual position counter and some other position related registers need to be modified or reset.

Otherwise the motor will return to the original motor position which was present before the JOG function was executed.

A simple way of doing this, is to send the special command 247 to the "Special command" -register, register number 211.

## 4.7 Expansion Module MAC00-FD4

---

### **Zero search - how to activate.**

In almost any system which is using some kind of position related mode it is necessary to find the mechanical zero point before normal operation of the motor can take place. Following description gives a guide line on how to activate the build-in *Zero search* function.

It is necessary to determine which kind of *Zero search* type that needs to be activated. The MAC motors offers a number of various *Zero search* types. Please consult the chapter *Mechanical Zero search, page 32* which explain in details which *Zero search* functions that exist and how they perform the *Zero search*.

Please find the section specifying the object 0x25 that can be accessed explicitly for configuration from the Devicenet network.

Another method for doing *Zero search* is to setup the motor for doing *Zero search* at startup selecting one of the "Power-up" *Zero search* modes. This can be done from the MacTalk configuration software and can be setup permanent in the motor without any further actions done through the DeviceNet interface. Please consult the chapter *Mechanical Zero search, page 32*.

If this method is preferred the motor will automatically perform the *Zero search* every time the motor is powered up or the 24V control supply is cycled.

### **Reading and clearing error codes.**

The register 35 is a combined error/status -register that represent the actual information about errors and the current motor status (accelerating, decelerating, motor in position) etc.

All this information is put into a single register that can be read all the time.

To clear the errors either write register 35 = 0

Another method is to execute the special command 225. This is done by writing to register 211 which will clear any actual errors.

Please notice that some errors are regarded as fatal and needs 24V power cycle to be cleared. Please consult the chapter *Error messages and error handling, page 40* for further details about all the error types and what may have caused the error situation.

### **Resetting the position.**

Sometimes it is necessary to reset the actual position counter.

When done manually it requires writing to multiple registers and special handling of the motor.

All this can be done by sending a the special command 247 to the command register 211 which will set the actual and requested position = 0.

The motor will stay stationary if it is set in a position related mode afterwards.



## 4.7 Expansion Module MAC00-FD4

---

### 4.7.20 Example - How to implement with a Omron PLC:

How to implement a JOG function using Omron PLC system.

This example sets the motor into velocity mode and sets a velocity depending on which direction to go and returns in Position mode when the jogging is finished.

Notice that Omron uses the syntax #1234 indicating a hexadecimal number in contrast to elsewhere in this chapter where the syntax 0x1234 is used for indicating a hexadecimal number.

1. Start by setting the velocity to 0, to prevent the motor from moving anywhere when the mode is set to "velocity".

Please observe that all values are 16bit and refers to the cyclic IO of 8 bytes each way. Please find the section covering IO-messages.

Basically this example uses the Register message type and accesses the registers relevant for this operation. That is P\_SOLL, V\_SOLL and the mode register.

Word 0: #0381 ;Set the bits in the structure and get register 3=P\_IST actual position  
Word 1: #053F ;Register 5, V\_SOLL, use command message = 31 + 32  
Word 2: #0000 ;Value=0  
Word 3: #0000 ;Value=0

2. Next step is to set the motor into velocity mode by writing register 2 = 1:

Word 0: #0381 ;Set the bits in the structure and get register 3=P\_IST actual position  
Word 1: #023F ;Register 2, MODE, use command message = 31 + 32  
Word 2: #0001 ;Value=1, velocity mode  
Word 3: #0000 ;Value=0

3. Now we set the velocity depending on which direction we want to use, we set either positive or negative value, we will set register 5, V\_SOLL for this purpose.

Word 0: #0381 ;Set the bits in the structure and get register 3=P\_IST actual position  
Word 1: #053F ;Register 5, MODE, use command message = 31 + 32  
Word 2: #07D0 ;Value=2000, velocity mode appx. 957 RPM (scaling: 2.1 x RPM)  
Word 3: #0000 ; -

4. Now the motor runs CW looking on the shaft.

If we want to go the other way we send:

Word 0: #0381 ;Set the bits in the structure and get register 3=P\_IST actual position  
Word 1: #053F ;Register 5, MODE, use command message = 31 + 32  
Word 2: #F830 ;Value=-2000, velocity mode appx. -957 RPM (scaling: 2.1 x RPM)  
Word 3: #FFFF ; -

5. If a motor stop is desired now there is several ways, one way is to set velocity = 0:

Word 0: #0381 ;Set the bits in the structure and get register 3=P\_IST actual position  
Word 1: #053F ;Register 2, MODE, use command message = 31 + 32  
Word 2: #0000 ;Value=0  
Word 3: #0000 ; -

## 4.7 Expansion Module MAC00-FD4

---

6. Now the motor is stopped at a stationary position, this position we want to set to 0, so we are using a special command. Write to command register 211. The command is 247:

Word 0: #0381 ;Set the bits in the structure and get register 3=P\_IST actual position  
Word 1: #D33F ;Register 211, Command, use command message = 31 + 32  
Word 2: #00F7 ;Value=247  
Word 3: #0000 ; -

This will set the 2 registers P\_IST = P\_NEW and P\_SOLL = P\_NEW per default  
P\_NEW = 0, so this will automatically set these registers to 0.  
P\_NEW has register number 163.

7. Now return to standard position control.  
We set the mode back to position (remember, velocity = 0):

Word 0: #0381 ;Set the bits in the structure and get register 3=P\_IST actual position  
Word 1: #023F ;Register 2, Command, use command message = 31 + 32  
Word 2: #0002 ;Value=2 = position mode  
Word 3: #0000 ; -

8. Next we must set the max. velocity to use

Word 0: #0381 ;Set the bits in the structure and get register 3=P\_IST actual position  
Word 1: #053F ;Register 5, MODE, use command message = 31 + 32  
Word 2: #07D0 ;Value=2000, velocity mode appx. 957 RPM (scaling: 2.1 x RPM)  
Word 3: #0000 ;

9. From here we can either use the standard position controller and change the message type to "Target position" and maybe set the incremental -bit if necessary.

Word 0: #0381 ;Set the bits in the structure and get register 3=P\_IST actual position  
Word 1: #2121 ;Use target position message type  
Word 2: #07D0 ;Value=2000, since we are running "incremental" the shaft position  
;is moved by 2000 counts  
Word 3: #0000 ; -

.....

Please also consult the user documentation for the Omron PLC and for a general motor register overview please consult *MacTalk communication*, page 378.

# 4.7 Expansion Module MAC00-FD4

## 4.7.21 Hardware in general

The schematic below shows the MAC00-FD4 module mounted inside the basic MAC motor. For further details regarding the external connectors, please see *Expansion MAC00-FD4 hardware description, page 243*

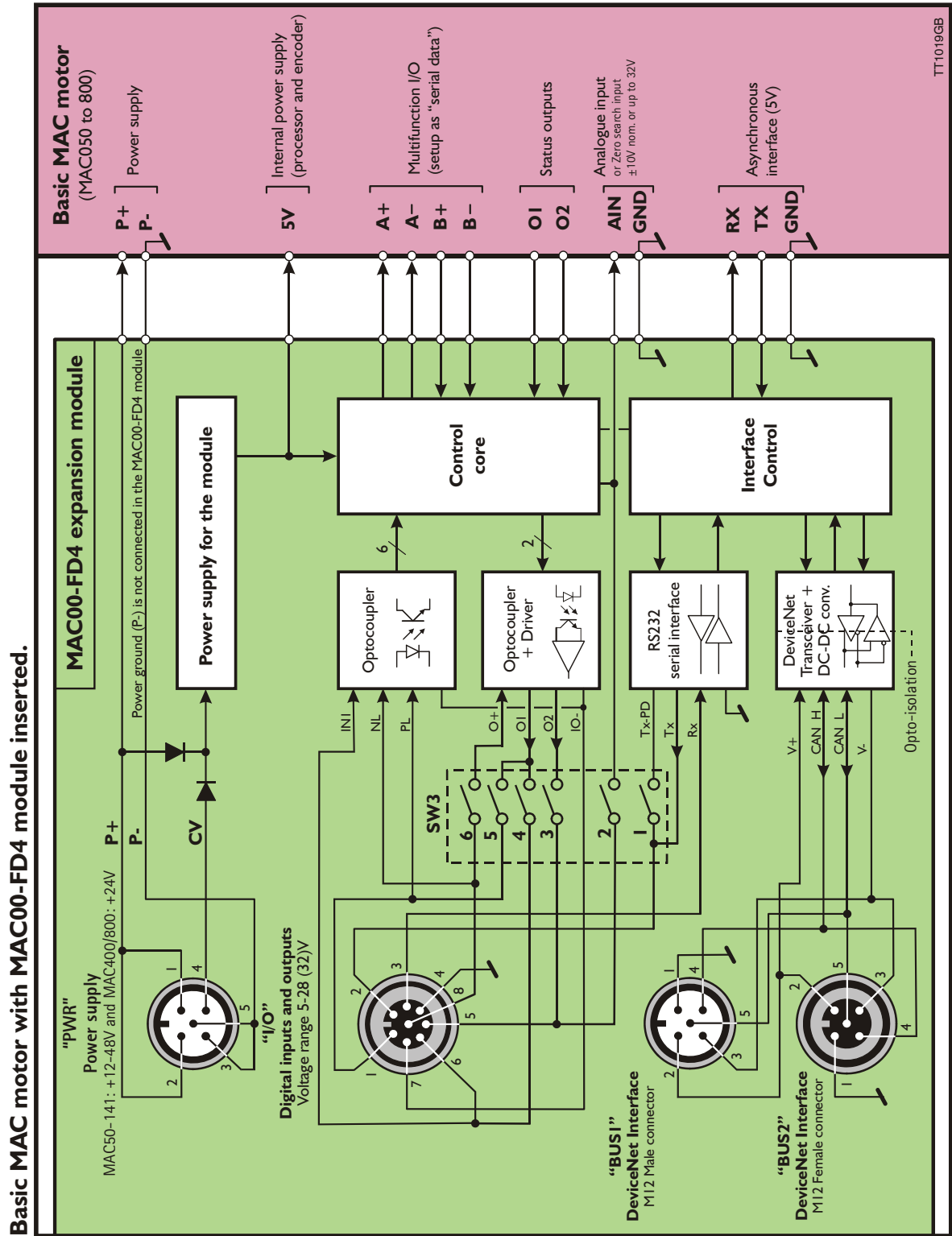

## 4.7 Expansion Module MAC00-FD4

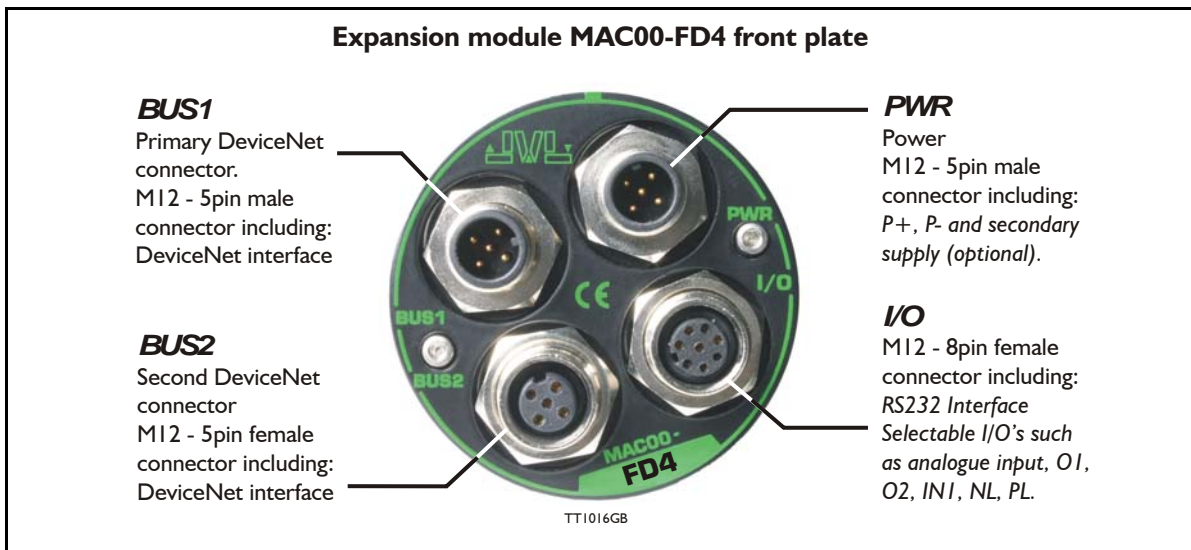

### 4.7.22 Expansion MAC00-FD4 hardware description

The MAC00-FD4 offers IP67 protection on MAC050-141 and M12 connectors which make it ideal for automation applications where no additional protection is desired. The M12 connectors offer solid mechanical protection and are easy to operate. The I/O signals available are restricted since only 4 I/O terminals are available. The I/Os connected to these 4 terminals must be selected via a small dip-switch.

The connector layout:

<b>“PWR” - Power input. M12 - 5-pin male connector</b>				
Signal name	Description	Pin no.	JVL Cable W1000M12 F5T05N	Isolation group
P+	Main supply +12-48VDC. Connect with pin 2 *	1	Brown	1
P+	Main supply +12-48VDC. Connect with pin 1 *	2	White	1
P-	Main supply ground. Connect with pin 5 *	3	Blue	1
CV	Control voltage +12-48VDC.	4	Black	1
P-	Main supply ground. Connect with pin 3 *	5	Grey	1
* Note: P+ and P- is each available at 2 terminals. Make sure that both terminals are connected in order to split the supply current in 2 terminals and thereby avoid an overload of the connector.				
<b>“BUS1” - DeviceNet interface. M12 - 5-pin male connector</b>				
Signal name	Description	Pin no.	Cable: user supplied	Isolation group
Drain	Shield for the DeviceNet interface - internally connected to the motor housing	1	-	2
V+	DeviceNet supply. Note that the MAC00-FP4 only senses at this terminal. The MAC00-FP4 contains its own power supply	2	-	2
V-	DeviceNet ground	3	-	2
CAN_H	DeviceNet interface. Positive signal line	4	-	2
CAN_L	DeviceNet interface. Negative signal line	5	-	2

(Continued next page)

## 4.7 Expansion Module MAC00-FD4

"BUS2" - DeviceNet interface. M12 - 5-pin female connector					
Signal name	Description	Pin no.	Cable: user supplied	Isolation group	
Drain	Shield for the DeviceNet interface - internally connected to the motor housing.	1	-	2	
V+	DeviceNet supply. Note that the MAC00-FP4 only senses at this terminal. The MAC00-FP4 contains its own power supply.	2	-	2	
V-	DeviceNet ground.	3	-	2	
CAN_H	DeviceNet interface. Positive signal line.	4	-	2	
CAN_L	DeviceNet interface. Negative signal line.	5	-	2	
"IO" - I/O's and RS232 interface. M12 - 8-pin female connector.					
Signal name	Description	Function	Pin no.	JVL Cable WI1000-M12 M8T05N	Isolation group
IOC	I/O terminal C.	SW3-5 = OFF : <i>PL</i> input SW3-5 = ON : <i>O1</i> output	1	White	3
Tx	RS232 interface - transmit output Important !: DIP1 must be turned ON. If addressing is used it must be turned ON at minimum one of the connected motors.		2	Brown	1
Rx	RS232 interface - receive input		3	Green	1
GND	RS232 Ground - also used with analogue input		4	Yellow	1
IOA	I/O terminal A.	SW3-2 = ON and SW3 DIP3 = OFF : <i>A1N</i> (Analogue input) SW3-2 = OFF and SWDIP 3 = ON : <i>O2</i> (output 2) ( <i>A1N</i> is the analogue input. Remember to use the GND terminal with <i>A1N</i> )	5	Grey	3 (1 when used as <i>A1N</i> )
IOB	I/O terminal B.	SW3-4 = OFF : <i>IN1</i> (input 1) SW3-4 = ON : <i>O1</i> (output 1)	6	Pink	3
IO-	I/O ground to be used with <i>IN1</i> , <i>NL</i> , <i>PL</i> , <i>O1</i> , <i>O2</i>		7	Blue	3
IOD	I/O terminal D.	SW3-6 = OFF : <i>NL</i> (negative limit input) SW3-6 = ON : <i>O+</i> (output supply)	8	Red	3
<b>Cable Screen</b> Some standard cables with M12 connector offer a screen around the cable. This screen on some cables is fitted to the outer metal of the M12 connector. When fitted to the MAC00-FD4 module, this means that the screen will have contact with the complete motor housing and thereby also the power ground (main ground).					
<b>Isolation groups</b> The MAC00-FD4 offers optical isolation at the digital inputs and outputs ( <i>IN1</i> , <i>NL</i> , <i>PL</i> and <i>O1-2</i> ). The table shows a number for each pin. This number refers to the isolation group to which the pin is connected. Isolation group 1 means that the terminal refers to the main ground ( <i>P-</i> , <i>GND</i> and the motor housing). Isolation group 2 means that the terminal refers to the DeviceNet interface ground ( <i>V-</i> ). Isolation group 3 means that the terminal refers to the I/O ground ( <i>IO-</i> )					

Defaults: Dip1-6 : ON, ON, OFF, OFF, ON, ON = TXPD:ON / IOA:A1N / IOB:IN1 / O1 / O+

### 4.7.23 General wiring considerations

Due to the nature of Devicenet needing a handshake procedure at initialization it is NOT recommended to power cycle 24V while the Devicenet bus system is running. If MAC400/800 motor types are used, keep the 24V control power on but cut the AC-voltage for the motor. In this way the DeviceNet connection is kept but the motor is held powerless and all motor movement is inhibited.

For the smaller series of MAC-motors (50-141) there is a separate power connection for the motor driver (*P+* terminal) which can be disabled while the control power (the *CV* terminal) is kept supplied with 24VDC without loss of communication.

## 4.7 Expansion Module MAC00-FD4

---

### 4.7.24 Connecting MAC00-FD4 to the DeviceNet-bus

Before you connect the MAC00-FD4 to the DeviceNet-bus make sure that the Baud-rate, the Node-ID and the termination is setup to the desired values.

On the DeviceNet bus it is possible to have a transmission speed (Baud-rate) of maximum 500 Kbit/s and a minimum of 125 Kbit/s. The Baud-rate depends on the cable length, and the wires cross-section. The table below have some recommendations for networks with less than 64 nodes. Recommended bus cable cross-section are according to CiA®:

Bus Distance (m)	Cross-section (mm <sup>2</sup> )	Terminator (ohm)	Baud-rate (Kbit/s)
100	0.34-0.6	150-300	500
250	0.34-0.6	150-300	250
500	0.5-0.6	150-300	125

The bus wires may be routed in parallel, twisted and/or shielded, depending on EMC requirements. The layout of the wiring should be as close as possible to a single line structure, in order to minimize reflections. The cable stubs for connection of the bus node shall be as short as possible, especially at high bit rates. The cable shielding in the house shall have a large contact area. For a drop cable a wire cross-section of 0.25 to 0.34 mm<sup>2</sup> would be an appropriate choice in many cases. In section 4.3.46 of this chapter there is an overview showing various JVL standard cables. All the JVL cables are twisted and shielded.

For bus lengths greater than 500m, a bridge or repeater device is recommended. Galvanic isolation between the bus nodes is optional. In the MAC00-FD4 modules the galvanic isolation is integrated to obtain best possible immunity against noise and differences in the voltage potential between the nodes.

## 4.7 Expansion Module MAC00-FD4

---

### 4.7.25 Necessary accessories to MAC-FD4:

On our web page [www.jvl.dk](http://www.jvl.dk) you can, under the downloads menu, find the EDS file for the MAC00-FD4 module, in the menu Field bus Interface Specifications Files. EDS means Electronic Data Sheet. This file contains the information about the MAC00-FD4 settings, that may be required to configure the setup and program in the master.

The MAC00-FD4 is a slave module on the DeviceNet-bus line, the master can be for example a PLC or a PC. If you are using a PLC as master, then make sure that it is provided with a DeviceNet® communications module, and that the correct programming tools are available. For getting support to the PLC master, it is more rewarding to use the PLC vendor.

The MacTalk program can be used to monitor various operations and make the initial set up on the motor see also *Using MacTalk to setup the motor, page 14*.

MacTalk is not a free-ware program. Please contact your JVL representative for further information.

## 4.7 Expansion Module MAC00-FD4

### 4.7.26 Hardware I/O setup

The drawing below shows the SW3 Dip-switch location. The various settings of SW3 is shown on the previous page.

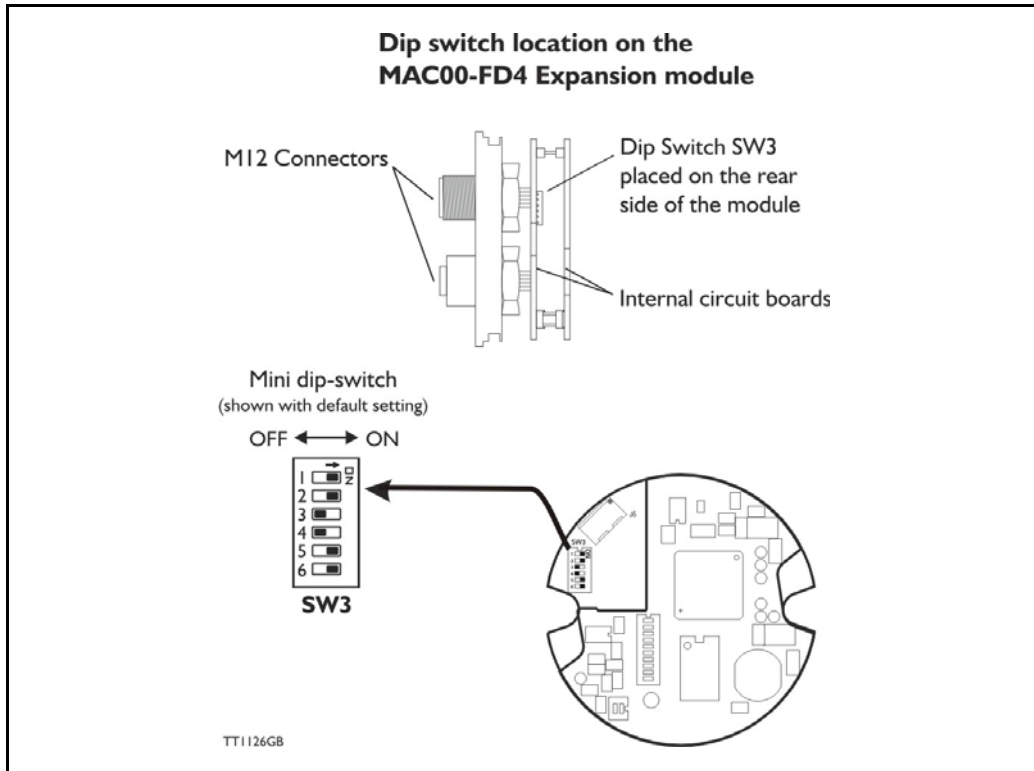

Switch description:

SW3	Description	Function	Signal name
Dip 1	RS232 interface - transmit output	ON = Enable	Tx
Dip 2 Dip 3	I/O terminal A	DIP2=ON and DIP3=OFF : AIN (Analogue input)	IOA
Dip 2 Dip 3	I/O terminal A	DIP2=OFF and DIP3=ON : O2 (output 2)	IOA
Dip 4	I/O terminal B	DIP4=ON : Output 1 DIP4=OFF : Input 1	IOB
Dip 5	I/O terminal C	DIP5=ON : O1 output DIP5=OFF : PL (positive limit input)	IOC
Dip 6	I/O terminal D	DIP6=ON : O+ (Output supply) DIP6=OFF : NL (Negative limit input)	IOD

The factory default setting is:

SW3	ON	OFF	Function
Dip 1	X		RS232 interface Enable
Dip 2 Dip 3	X	X	O2 (output 2)
Dip 4		X	Input 1
Dip 5	X		O1 output
Dip 6	X		O+ (output supply)



## 4.7 Expansion Module MAC00-FD4

### 4.7.27 Cables for the MAC00-FD4

The following cables equipped with M12 connector can be supplied by JVL.

MAC00-FD4 Connectors				Description	JVL Order no.	Photo
"BUS1" 5-pin Male B-coded	"BUS2" 5-pin Female B-coded	"I/O" 8-pin Female	"PWR" 5-pin Male			
		X		RS232 Interface cable. Connects directly from MAC00-FD4 to PC Length: 5m (197 inch)	RS232-M12-1-5-8	
			X	Cable (Ø5.5mm) with M12 female 5-pin connector loose wire ends 0.35mm <sup>2</sup> (22AWG) and foil screen. Length: 5m (197 inch)	WI1000-M12F5T05N	
			X	Same as above but 20m (787 inch)	WI1000-M12F5T20N	
		X		Cable with M12 male 8-pin connector loose wire ends 0.22mm <sup>2</sup> (24AWG) and screen. Length: 5m (197 inch)	WI1000-M12M8T05N	
		X		Same as above but 20m (787 inch)	WI1000-M12M8T20N	
	X			DeviceNet cable with M12 male 5-pin connector, loose ends and screen. Length: 5m (197 inch).	WI1006-M12M5S05R	
	X			Same as above but 15m (591 inch)	WI1006-M12M5S15R	
X				Devicenet cable with M12 female 5-pin connector, loose ends and screen. Length: 5m (197 inch)	WI1006-M12F5S05R	
X				Same as above but 15m (591 inch)	WI1006-M12F5S15R	
<b>Termination resistor</b>						
	X			Loose DeviceNet male M12 termination resistor.	WI1008-M12M5STR4	
<b>Protection caps. Optional if connector is not used, to protect from dust / liquids.</b>						
	X	X		IP67 protection cap for M12 female connector.	WI1000-M12FCAP1	
X			X	IP67 protection cap for M12 male connector.	WI1000-M12MCAP1	

**Important:** Please note that the cables are a standard type. They are not recommended for use in cable chains or where the cable is repeatedly bent. If this is required, use a special robot cable (2D or 3D cable). See also *Accessories*, page 415 where additional M12 connectors are shown.

## 4.8 Expansion Module MAC00-FP2/FP4

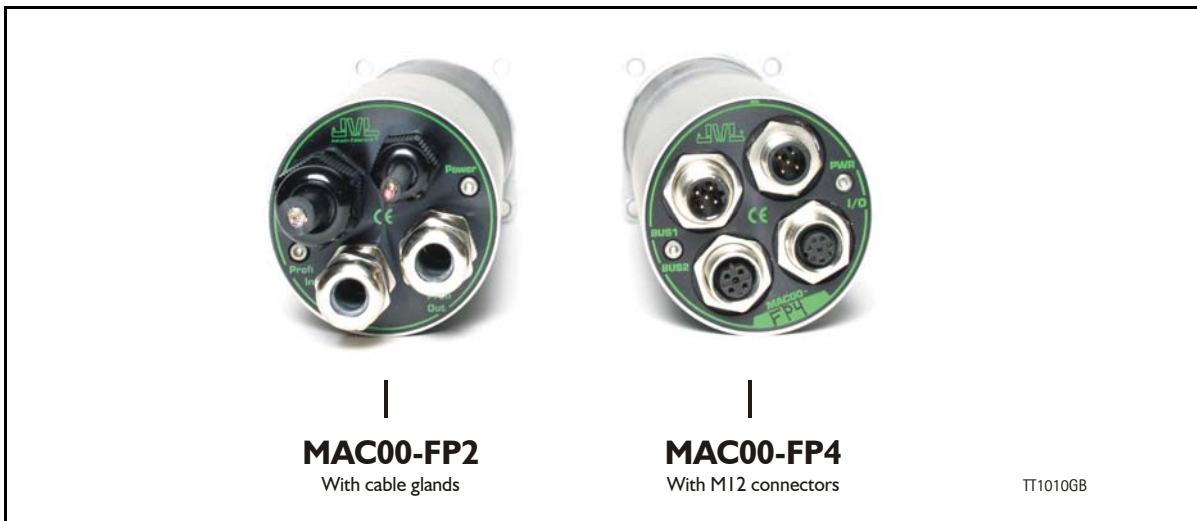

### 4.8.1 Profibus module MAC00-FP2 and FP4 Introduction

The MAC00-FP2 and FP4 are Profibus-DP slaves. They are capable of running at Baud-rates up to 12Mbit.

All the registers<sup>1</sup> of the MAC motor can be read and written.

The modules include 6 inputs, 2 of which are end-limit inputs. These can be read from the Profibus-DP. The end-limit inputs can automatically halt the motor. The other inputs can be used to activate different movements.

The MAC motor is controlled by writing to the input data (9 bytes).

The expansion modules MAC00-FP2 and FP4 can be mounted on standard MAC1500 the scaling is [RPM] x 2.837, so 1000 RPM = 2837 [counts/smpl.]

Both modules offer the same functions but with the following hardware differences:

Type	Protection class	Connectors		
		I/O and interface	Power supply	Bus interface
MAC00-FP2	IP67/IP65*	Cable glands (Mini crimp connectors internally)	Cable glands (Screw terminals internally)	Cable glands x 2 (Screw terminals internally)
MAC00-FP4	IP67/IP65*	M12	M12	M12 B-coded (x2)

Note\*: IP65 on MAC400-800

Both modules are delivered without any cables as standard.

Optionally the MAC00-FP2 module can be delivered with cable in selected lengths. Also cables for the MAC00-FP4 with M12 connectors are available.

The first part of this section deals with the common features of both modules. Please see the latter pages for specific information about each module, such as example connection diagrams.

<sup>1</sup> A list of the typically used registers can be found in *Serial Quick Guide (MacTalk protocol)*, page 378.

<sup>2</sup> The FlexMac commands are described in *FastMac commands*, page 257.

## 4.8 Expansion Module MAC00-FP2/FP4

### 4.8.2 MAC00-FP2 and FP4 Address and Termination setup

Each unit connected to the Profibus must be set up with a unique address. The illustration below shows how the address and termination can be set on the internal dip switch. The dip switch is located on the internal circuit board.

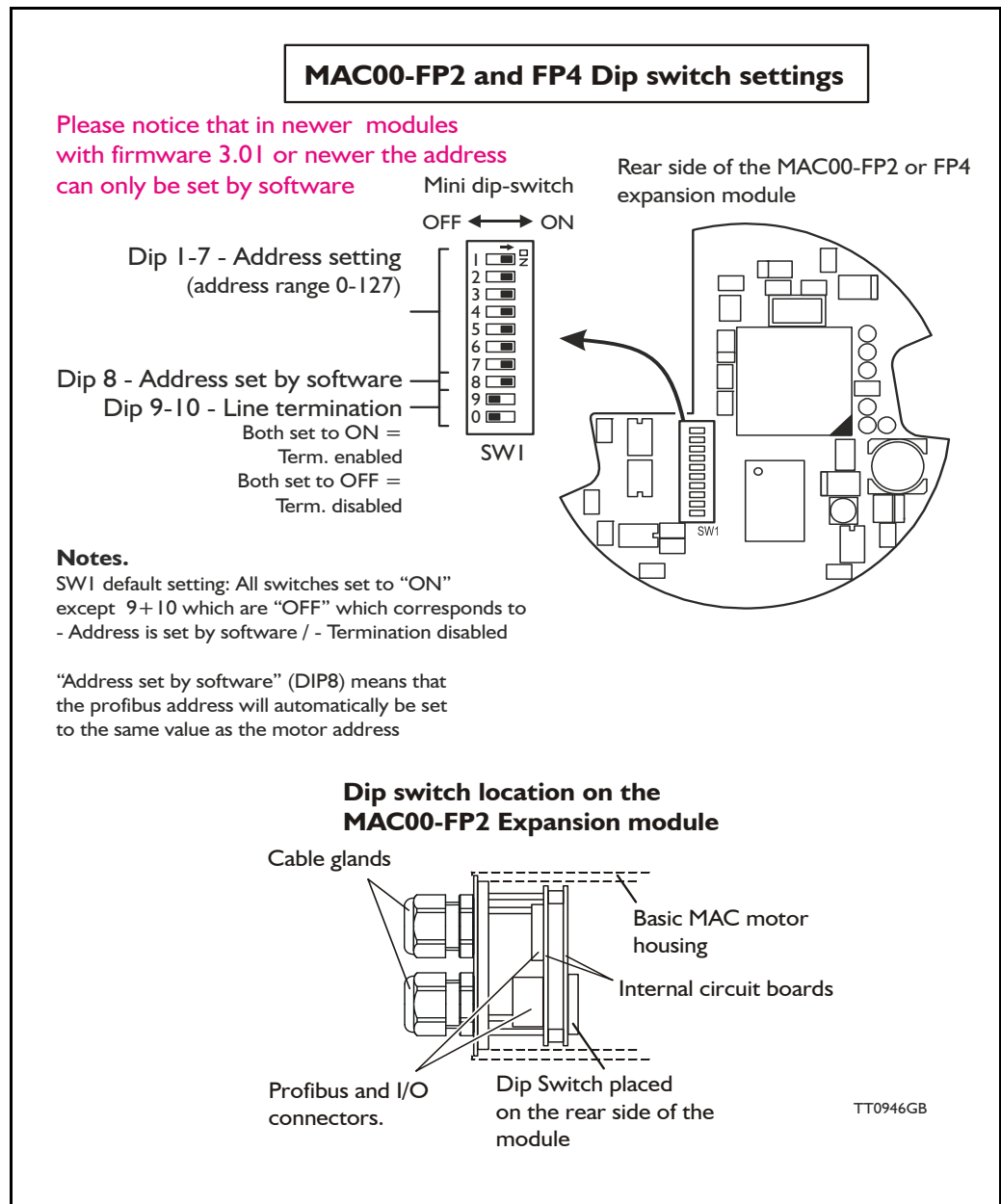

**Important:** On newer modules with firmware 3.01 or 3.02 the dip switch 1 to 8 has been disabled and the address can only be set in software by using for example MacTalk. Please contact your JVL distributor if it is crucial to use the dip switch for address setup.

## 4.8 Expansion Module MAC00-FP2/FP4

---

### 4.8.3 Output data (Master->Slave)

The MAC00-FP2/FP4 module contains 9 bytes of output data.

Address	Name	Description
0	Write data 3 (MSB)	Data to write to register
1	Write data 2	--- " ---
2	Write data 1	--- " ---
3	Write data 0 (LSB)	--- " ---
4	Write register selector	The register to write
5	Read register selector	The register to read
6	Direct register	Direct FlexMac command
7	Command	Bits for commanding reads/write
8	Input setup	Bits for input setup

#### Write data

For 16 bit registers, the data must be placed in Write data 0 and Write data 1.  
For 32 bit registers, the data must be placed in Write data 0-3.

#### Write register selector

The number of the register to write to should be placed here. The register must be in the range 1-255.

#### Read register selector

The number of the register to read from should be placed here. The register must be in the range 1-255.

#### Direct register

This register can be used to execute a FlexMac<sup>2</sup> command. When writing to this Register, the command will be executed immediately. The bit 0-6 is the command, and bit 7 is not used. If the same command is to be executed twice, bit 7 can be toggled. The command is accepted when the "Last direct register", in the input data, has the same value as this register.

## 4.8 Expansion Module MAC00-FP2/FP4

### Command

Bit	7	6	5	4	3	2	1	0
Function	Write Toggle	Read Toggle	Write 32 bit	Read 32 bit	Auto write	Auto read	Reserved	Reserved

Bit 7 (Write toggle) is used for writing data to the selected register (Write register selector). When this bit is toggled, writing is executed. The write command is accepted when Bit 7 in the command status (output data byte 7) is equal to this bit.

Bit 6 (Read toggle) is used for reading data from the selected register (Read register selector). When this bit is toggled, reading is executed. The read command is accepted when Bit 6 in the command status (output data byte 7) is equal to this bit.

Bit 5 (Write 32 bit) Set this to 1 if writing to a 32 bit register and 0 if writing to a 16 bit register.

Bit 4 (Read 32 bit) Set this to 1 if reading from a 32 bit register and 0 if reading from a 16 bit register.

Bit 3 (Auto write) When this bit is 1, the data written in write data 0-3, is transferred to the MAC motor immediately, regardless of the write toggle bit.

Bit 2 (Auto read) When this bit is 1, the data in read data 0-3 is updated all the time, regardless of the read toggle bit.

Bit 1 and Bit 0 should be 0.

### Input setup

Bit	7	6	5	4	3	2	1	0
Function	-	Reset end limit	PL Enable	NL Enable	Input mode			

Bit 6 (Reset end-limit) When this bit is 1, the end limit condition is reset, if no end limits are activated.

Bit 5 (PL Enable) When this bit is 1, the positive end-limit is enabled.

Bit 4 (NL Enable) When this bit is 1, the negative end-limit is enabled.

Bit 3-0 (Input mode) these bits select the current input mode. See section *Input modes*, page 255 for details.

## 4.8 Expansion Module MAC00-FP2/FP4

---

### 4.8.4 Write to a register example

If a new velocity need to be written to the motor it is done after this step by step procedure.

1. Write the new speed value to the 4 databytes (32 bits) on address 0 to 3.
2. Setup the register number where the data must be written to.  
In this case its the velocity register which is register 5 so this number must be written into the "write register selector" address 4.
3. In the "Command" register at address 7 the "Write 32bit" and the "Write toggle" must be toggled.
4. Wait until the "Write toggle" bit in the "Command status" register is the same as the "write toggle" in the "Command" register. Only when they are equal the write cycle is completely finished.

#### **Definitions:**

Toggle: Change to opposite state. (from 0 to 1 or from 1 to 0). On bit level it correspond to making an inverse of the bit.

## 4.8 Expansion Module MAC00-FP2/FP4

### 4.8.5 Input data (Slave->Master)

The MAC00-FP2/4 contains 8 bytes of input data.

Address	Name	Description
0	Read data 3 (MSB)	Data read from register
1	Read data 2	--- " ---
2	Read data 1	--- " ---
3	Read data 0	--- " ---
4	Motor status	Status bits for the motor
5	Input status	Status of inputs
6	Last direct register	Last accepted direct FlexMac command
7	Command Status	Status bits for commands

#### Read Data

For 16 bit registers, the read value will be placed in Read data 0 and Read data 1.  
For 32 bit registers, the read value will be placed in Read data 0-3.

#### Motor status

Bit	7	6	5	4	3	2	1	0
Function	-	Decelerating	Accelerating	In position	-	-	-	Error

Bit 6 (Decelerating) this bit is 1 when the motor is decelerating.

Bit 5 (Accelerating) this bit is 1 when the motor is accelerating.

Bit 4 (In position) this bit is 1 when the motor has reached its commanded position.

Bit 0 (Error) this bit is 1 when a motor error has occurred.

#### Input status

Bit	7	6	5	4	3	2	1	0
Function	-	-	PL	NL	IN4	IN3	IN2	IN1

Bit 5 (PL) Positive limit input.

Bit 4 (NL) Negative limit input.

Bit 3-0 (INx) user inputs.

#### Last direct register

See *Direct register*, page 251 for details.

## 4.8 Expansion Module MAC00-FP2/FP4

---

### Command status

Bit	7	6	5	4	3	2	1	0
Function	Write Toggle	Read Toggle	-	-	Status			

Bit 7 (Write Toggle) this bit indicates when writing is completed. See *Command*, page 252 for details.

Bit 6 (Read Toggle) this bit indicates when reading is completed. See *Command*, page 252 for details.

Bit 3-0 (Status) These bits indicate the status of the MAC00-FP2/FP4. The following status codes are possible:

Code	Description
0	OK – Idle
1	Executing Input
2	Executing Output
3	Limit switch active
4	Profi error
5	Connecting to MAC motor

### 4.8.6 Input modes

The 4 user inputs can be used to execute different move commands. The following input modes can be selected:

Mode	Description
0	Passive
1	Absolute+Relative
2-14	Reserved
15	Custom

#### Passive mode (0)

When this mode is selected, the user inputs are ignored. The inputs can be read in output data 5 for other purposes.

#### Absolute + Relative mode (1)

When this mode is selected. the inputs have the following functions:

- IN1: Selects the absolute position in position register 1.
- IN2: Selects the absolute position in position register 2.
- IN3: Moves relative the distance in position register 3.
- IN4: Moves relative the distance in position register 4.

The action is executed when an inactive-to-active transition is detected on the input.

#### Custom mode (15)

When this mode is selected, the action of each input can be selected with the slave parameters. See *Slave parameters*, page 256.



## 4.8 Expansion Module MAC00-FP2/FP4

---

### 4.8.7 Slave parameters

When configuring the profibus, it is possible to set some parameters for the slave. These parameters are setup during startup and cannot be changed during operation.

#### **XX Input level**

Using these parameters, the input level of the inputs IN1, IN2, IN3, IN4, NL and PL can be selected.

Possible values:

- Active high : The input will be active, when a signal is applied.
- Active low : The input will be active, when no signal is applied.

#### **End-limit action**

Using this parameter, the action taken when an end limit is activated can be selected.

Possible values:

- Velocity = 0 : When the end-limit is activated, the velocity will be set to 0 and the motor will decelerate and stop. If the motor should run again, the user must manually set a new velocity.
- Passive mode : When the end-limit is activated, the actual mode will be changed to passive. In passive mode the motor is short-circuited and can be rotated.

In firmware version 1.4 or higher, the “end-limit action” is also active if the Profibus is going off-line but it needs to be online before it goes off line before the feature is enabled.

#### **Input debounce**

Using this parameter, an input filter can be activated.

Possible values:

- Disabled No filtering will be done on the inputs.
- Enabled The inputs are filtered, resulting in better noise immunity but slower response. When the filter is enabled, there will be a delay at the input of about 5ms.

#### **Input x action**

Using these parameters, up to 3 actions can be assigned to each input.

These actions are used when the custom input mode is selected. See *Input modes*, page 255.

The action is defined by a FlexMac command. See *FastMac commands*, page 257.

Possible values are 0-127, where 0 represents no action.

## 4.8 Expansion Module MAC00-FP2/FP4

### 4.8.8 FastMac commands

Using the FastMac commands, it is possible to activate a set of registers and set the mode of the motor using a single command. The command is composed of two parts. The first part is the mode that the motor will use.

The following 4 modes can be selected:

Value	Motor mode after command	Format
0	Passive	Command = 0 + Register N
32	Velocity	Command = 32 + Register N
64	Position	Command = 64 + Register N
96	<No change>	Command = 96 + Sub-command N

The second part of the command is a register number or sub-command number. The following table shows the register numbers:

N	Register	N	Register	N	Register	N	Register
0	P1	8	V1	16	A1	24	L1
1	P2	9	V2	17	A2	25	L2
2	P3	10	V3	18	A3	26	L3
3	P4	11	V4	19	A4	27	L4
4	P5	12	V5	20	T1	28	Z1
5	P6	13	V6	21	T2	29	Z2
6	P7	14	V7	22	T3	30	Z3
7	P8	15	V8	23	T4	31	Z4

The following table shows the sub-commands:

N	Command	N	Command
0	No operation	16	Start search zero
1	Reset error	17	No operation
2	P_SOLL = 0	18	No operation
3	P_IST = 0	19	Reserved
4	P_FNC = 0	20	Select absolute position mode
5	V_SOLL = 0	21	Select relative position mode using P_SOLL
6	T_SOLL = 0	22	Select relative position mode using P_FNC
7	Reset IN_POS, ACC,DEC	23	No operation
8	$P\_FNC = (FLWERR - P7) * 16$	24	No operation
9	$P\_FNC = (FLWERR - P8) * 16$	25	No operation
10	Reserved	26	No operation
11	Reserved	27	No operation
12	Activate P1,V1,A1,T1,L1,Z1	28	No operation
13	Activate P2,V2,A2,T2,L2,Z2	29	No operation
14	Activate P3,V3,A3,T3,L3,Z3	30	Reserved
15	Activate P4,V4,A4,T4,L4,Z4	31	Reserved

## 4.8 Expansion Module MAC00-FP2/FP4

---

### Examples of FastMac commands

Change velocity mode and activate register V1 :

32 + 8 = FastMac command 40

Activate register P5 and change to position mode

64 + 4 = FastMac command 68

Activate register T3 and change to position mode

64 + 22 = FastMac command 86

Activate P0,V0,A0,T0,L0 and Z0 without changing the mode:

96 + 12 = FastMac command 108

# 4.8 Expansion Module MAC00-FP2/FP4

## 4.8.9 MAC00-FP2 and FP4 description of connections

The following pages describe the different aspects of connecting the modules MAC00-FP2 and FP4.

## 4.8.10 MAC00-FP2 Connectors

MAC00-FP2 rear plate layout:

The illustration below shows all the internal connectors in the module. The profibus and power connectors are easy-to-use screw terminals. If the I/Os are used, they require a JVL cable type WG0402 (2m), WG0410 (10m) or WG0420 (20m). See also the appendix for cable and connector accessories.

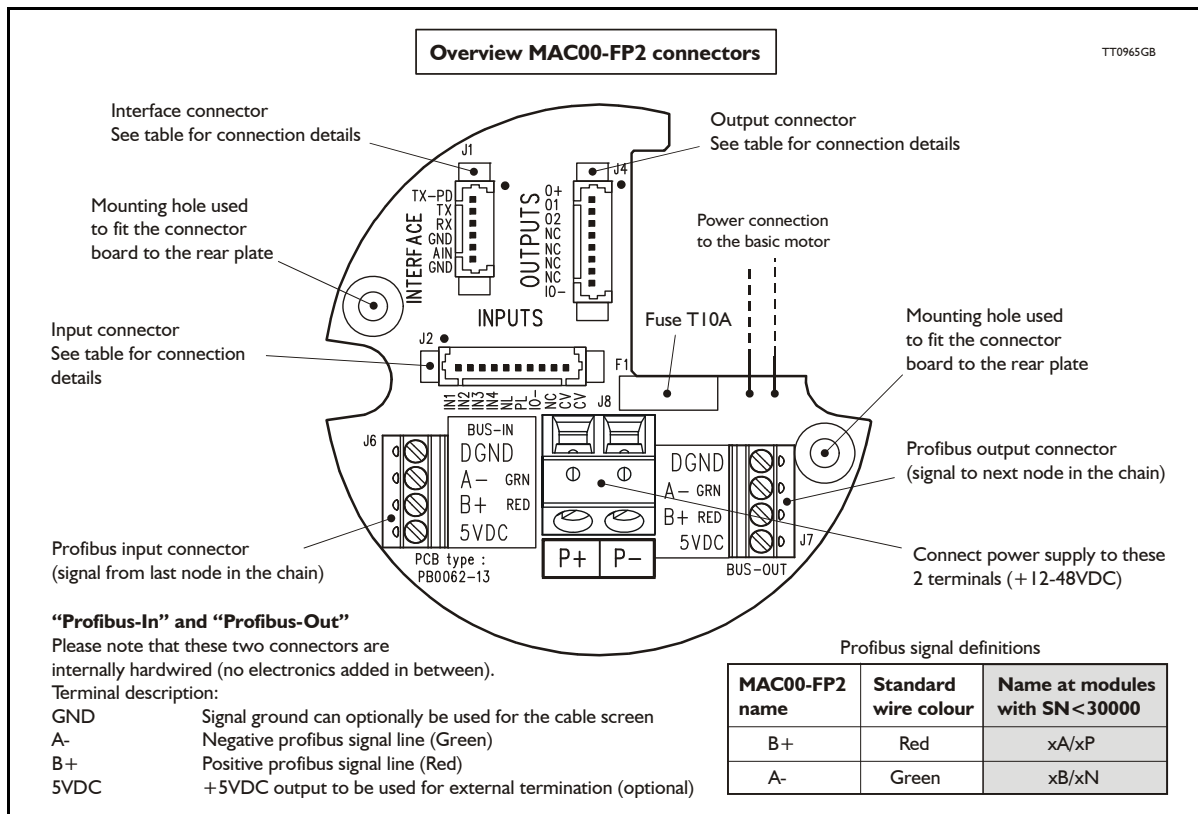

## 4.8 Expansion Module MAC00-FP2/FP4

### 4.8.11 MAC00-FP2 option with cables (optional)

The MAC00-FP2 type number only covers the basic module, i.e. without any cables. If a number is added after the basic type number, for example MAC00-B2-10, this suffix indicates that the module is fitted with 10 m of cable in the I/O. The I/O cable covers all the signal lines, i.e. RS232, Digital input 1-4, Limit inputs NL and PL and the Digital outputs 1-4.

Please note the WG0420 table below is not valid for cables delivered before 1.10.2002.

Digital Inputs - Internal connector J2			
Signal name	Pin no.	Description	Wire colour
IN1	1	Digital input 1	Red/black
IN2	2	Digital input 2	Green/black
IN3	3	Digital input 3	Violet
IN4	4	Digital input 4	Violet/white
NL	5	Negative limit input - If not used, do not connect.	Grey
PL	6	Positive limit input - If not used, do not connect.	Grey/black
IO-	7	I/O ground. Shared with the output ground (O-)	Pink/black
NC	8	(Reserved)	Black/white
CV	9	Secondary supply. Used during emergency stop *	Light green **
CV	10	Secondary supply. Used during emergency stop *	White
Digital Outputs - Internal connector J4			
Signal name	Pin no.	Description	Wire colour
O+	1	Supply for outputs - Must be connected to an ext. supply.	Red/white
O1	2	Digital output 1 - PNP output - Max. 25mA	Green/white
O2	3	Digital output 2 - PNP output - Max. 25mA	Yellow/black
NC	4	(Reserved)	Blue/white
NC	5	(Reserved)	Orange/white
NC	6	(Reserved)	Brown/white
NC	7	(Reserved)	Pink
IO-	8	I/O ground. This ground is shared with the input ground	Black
Interface - including analogue input - Internal connector J1			
Signal name	Pin no.	Description	Wire colour
TXPD	1	Transmit pull-down (Connect to TX if addr. not used)	Red
TX	2	RS232 Transmit (Connect to TXPD if addr. not used).	Green **
RX	3	RS232 Receive (connect to GND if not used).	Yellow
GND	4	Ground for RS232	Blue
AIN	5	Analogue input +/-10V or Zero sensor input	Orange
GND	6	Ground for AIN	Brown
Cable Screen			
The cable-screen is internally connected to motor housing. Externally it must be connected to earth.			
Unused wire			
Orange/Black - is not used internally. It must be left unconnected.			

\* : The VC terminals are only available on modules with serial number >25000

\*\* : The light green wire (CV) can be difficult to distinguish from the green wire (TX) on some cables.

**Important:** Please note that the cables are a standard type. They are not recommended for use in cable chains or where the cable is repeatedly bent. If this is required, use a special robot cable (2D or 3D cable).

## 4.8 Expansion Module MAC00-FP2/FP4

### 4.8.12 Assembly instructions for profi cables

Remove the insulation from the cable, as shown in the accompanying picture.

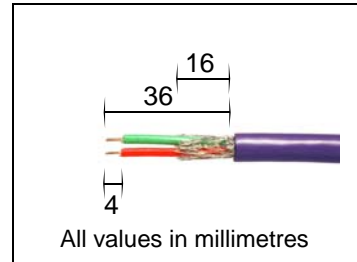

Fit the plastic part of the gland on the cable, and fold the screen around it. Remember to first feed the cable through the nut.

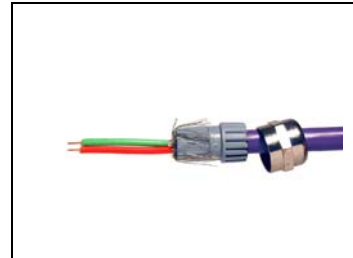

Feed the cables through the cable glands in the rear plate of the module and tighten the nuts.



Screw the wires into the module. The red wire must go into the B+ terminal, and the green must go into the A-terminal.

The input and output terminals can be swapped if required. There is no difference between input and output on the board which means that it is purely hard-wired.

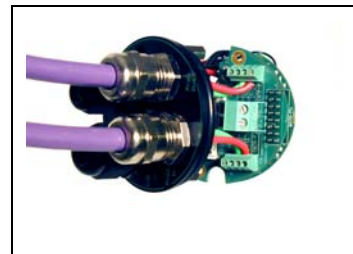

Attach the circuit board to the rear plate with the two screws. REMEMBER to use the spring washers included.



The table below shows the difference between Siemens naming conventions and the naming on the MAC00-FPx.

MAC00-FPx name	Siemens name	Standard wire colour
B+	B	Red
A-	A	Green

**IMPORTANT:**  
use spring washer



## 4.8 Expansion Module MAC00-FP2/FP4

### 4.8.13 MAC00-FP2 - How to connect the RS232 interface

The illustration below shows how to connect the MAC00-FP2 directly to a PC COM port. The drawing is based on standard cables from JVL, type WG0402, WG0410 or WG0420. See also *Accessories, page 415* for a complete list of cables and connectors. If the MAC motor is connected to the same RS232 line as other motors, the terminal TX-PD should only be connected at one of the motors. If one of JVL's standard RS232 cables (RS232-9-1 or -n) is used between the DSUB connector shown and the PC com port, the RX and TX pins must be swapped since they cross in these standard cables.

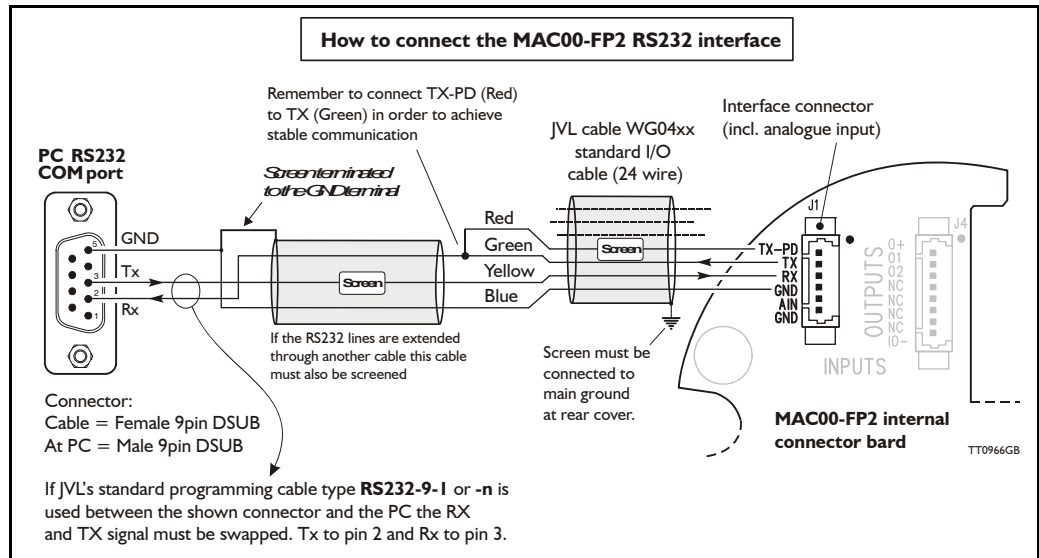

### 4.8.14 Operation with dual supply for emergency situations

In many applications it is intended that positional data and other setup information is retained during an emergency situation. It is however also required by law in many countries that the main power for energizing the motor is removed in such a situation. To meet both of these requirements, the MAC motor equipped with a MAC00-FPx module offers a secondary supply input called "CV". If the main supply at the P+ terminal is removed, the internal control circuitry can be kept "alive" by maintaining a supply at the "CV" terminal.

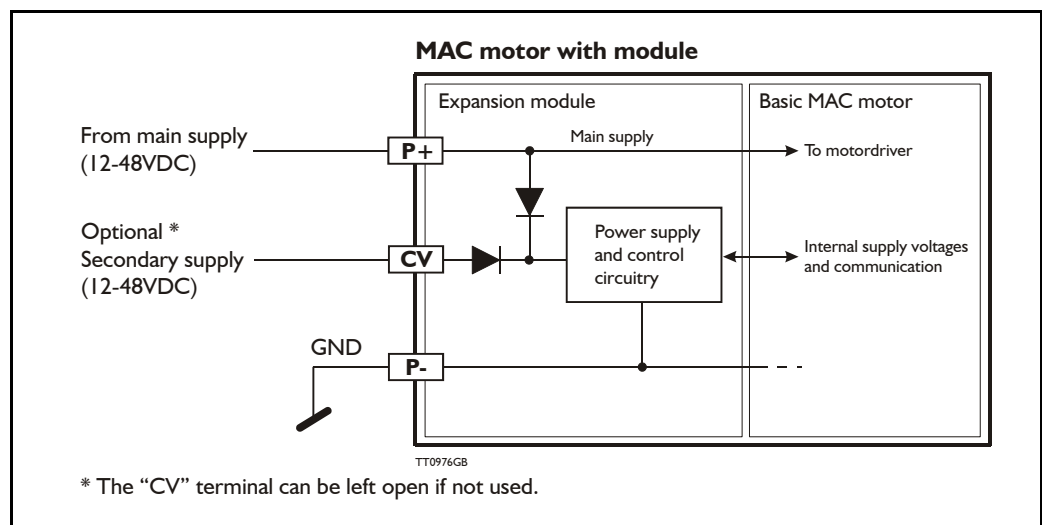

## 4.8 Expansion Module MAC00-FP2/FP4

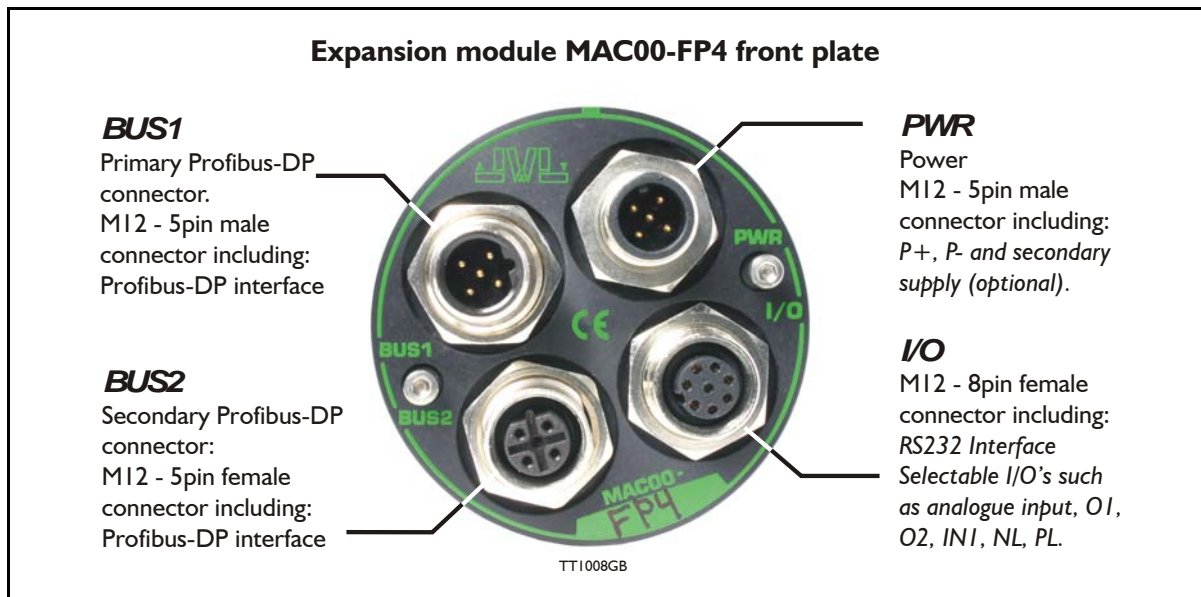

### 4.8.15 Expansion MAC00-FP4 hardware description

The MAC00-FP4 offers IP67 on MAC050-141 protection and M12 connectors which make it ideal for automation applications where no additional protection is desired. The M12 connectors offer solid mechanical protection and are easy to unplug compared to the FP2 module which has cable glands. The signals available are restricted compared to the FP2 module since only 4 I/O terminals are available. The I/Os connected to these 4 terminals must be selected by a small dip-switch.

The connector layout:

<b>"PWR" - Power input. M12 - 5-pin male connector</b>				
Signal name	Description	Pin no.	JVL Cable W11000M12 F5T05N	Isolation group
P+	Main supply +12-48VDC. Connect with pin 2 *	1	Brown	1
P+	Main supply +12-48VDC. Connect with pin 1 *	2	White	1
P-	Main supply ground. Connect with pin 5 *	3	Blue	1
CV	Control voltage +12-48VDC.	4	Black	1
P-	Main supply ground. Connect with pin 3 *	5	Grey	1
* Note: P+ and P- are each available at 2 terminals. Make sure that both terminals are connected in order to split the supply current in 2 terminals and thereby avoid an overload of the connector.				
<b>"BUS1" - Profibus-DP interface. M12 - 5-pin male connector</b>				
Signal name	Description	Pin no.	Cable: user supplied	Isolation group
-	Reserved for future purpose - do not connect	1	-	2
A-	Terminal A (Siemens syntax) for the Profibus-DP interface	2	-	2
DGND	Profibus-DP interface ground	3	-	2
B+	Terminal A (Siemens syntax) for the Profibus-DP interface	4	-	2
SHIELD	Cable shield. Internally conn. to the motor housing.	5	-	2

(Continued next page)



## 4.8 Expansion Module MAC00-FP2/FP4

MAC00-FP4 connection description - continued.

<b>"BUS2" - Profibus-DP Interface. M12 - 5-pin female connector</b>					
Signal name	Description	Pin no.	Cable: user supplied	Isolation group	
5VDC	5V output. Can be used for ext. termination (Max 40mA)	1	-	2	
A-	Terminal A (Siemens syntax) for the Profibus interface	2	-	2	
DGND	Profibus-DP interface ground	3	-	2	
B+	Terminal B (Siemens syntax) for the Profibus interface.	4	-	2	
SHIELD	Cable shield. Internally connected to the motor housing.	5	-	2	
<b>"IO" - I/Os and RS232 interface. M12 - 8-pin female connector.</b>					
Signal name	Description	Function	Pin no.	JVL Cable W11000-M12 M8T05N	Isolation group
IOC	I/O terminal C.	DIP 5 = OFF : <i>PL</i> input DIP 5 = ON (default) O1 ( <i>output PNP 25mA</i> )	1	White	3
Tx	RS232 interface - transmit output Important !: <b>DIP1 must be turned ON</b> . If addressing is used it must be turned ON at minimum one of the connected motors.		2	Brown	1
Rx	RS232 interface - receive input		3	Green	1
GND	RS232 Ground - also used with analogue input		4	Yellow	1
IOA	I/O terminal A.	DIP 2 = ON(default) and DIP 3 = OFF (default): <i>AIN</i> (Analogue in or <i>Zero search</i> input)  DIP2 = OFF and DIP 3 = ON : O2 (output 2 / PNP 25mA)	5	Grey	3 (1 when used as AIN)
IOB	I/O terminal B.	DIP 4 = OFF (default): <i>IN1</i> ( <i>input 1</i> ) DIP 4 = ON : O1 ( <i>PNP 25mA</i> ) (output 1)	6	Pink	3
IO-	I/O ground to be used with IN1, NL, PL, O1, O2		7	Blue	3
IOD	I/O terminal D.	DIP 6 = OFF: <i>NL</i> (negative limit input)  DIP 6 = ON(default): O+ ( <i>outp.sup.</i> )	8	Red	3
<b>Cable Screen</b>					
Some standard cables with M12 connector offer a screen around the cable. This screen on some cables is fitted to the outer metal at the M12 connector. When fitted to the MAC00-FP4 module, this means that the screen will have contact with the complete motor housing and thereby also the power ground (main ground).					
<b>DIP-switch default setting</b>					
The Dip-switches are default set to the following positions: DIP1 (TX-PD)=ON DIP2 (AIN to IOA terminal) = ON DIP3 (O2 to IOA terminal) = OFF DIP4 (O1 to IOB) = OFF DIP5 (O1 to IOC) = ON DIP6 (O+ to IOD) = ON					
<b>Isolation groups</b>					
The MAC00-FP4 offers optical isolation at the digital inputs and outputs (IN1, NL, PL and O1-2). The table shows a number for each pin. This number refers to the isolation group to which the pin is connected. Isolation group 1 means that the terminal refers to the main ground (P-, GND and the motor housing). Isolation group 2 means that the terminal refers to the Profibus-DP interface ground (DGND). Isolation group 3 means that the terminal refers to the I/O ground (IO-)					

## 4.8 Expansion Module MAC00-FP2/FP4

### 4.8.16 Cables for the MAC00-FP4

The following cables equipped with M12 connector can be supplied by JVL.

MAC00-FP4 Connectors				Description	JVL Order no.	Photo
"BUS1" 5-pin Male B-coded	"BUS2" 5-pin Female B-coded	"I/O" 8-pin Female	"PWR" 5-pin Male			
		X		RS232 Interface cable. Connects directly from MAC00-FP4 to PC Length: 5m (197 inch)	RS232-M12-1-5-8	
			X	Cable (Ø5.5mm) with M12 female 5-pin connector loose wire ends 0.35mm <sup>2</sup> (22AWG) and foil screen. Length: 5m (197 inch)	WI1000-M12F5T05N	
			X	Same as above but 20m (787 inch)	WI1000-M12F5T20N	
		X		Cable with M12 male 8-pin connector loose wire ends 0.22mm <sup>2</sup> (24AWG) and screen. Length: 5m (197 inch)	WI1000-M12M8T05N	
		X		Same as above but 20m (787 inch)	WI1000-M12M8T20N	
	X			Profibus DP cable with M12 male 5-pin connector B-coded, loose ends and screen. Length: 5m (197 inch).	WI1026-M12M5S05R	
	X			Same as above but 15m (591 inch)	WI1026-M12M5S15R	
X				Profibus DP cable with M12 female 5-pin connector B-coded, loose ends and screen. Length: 5m (197 inch)	WI1026-M12F5S05R	
X				Same as above but 15m (591 inch)	WI1026-M12F5S15R	
<b>Loose connectors and termination resistor</b>						
	X			Loose Profibus DP male M12 connector. B-coded. Internal screw terminals.	WI1028-M12M5VC1	
X				Loose Profibus DP female M12 connector. B-coded. Internal screw terminals.	WI1028-M12F5VC1	
	X			Profibus DP male M12 termination resistor. B-coded.	WI1028-M12M4STR3	
<b>Protection caps. Optional if connector is not used, to protect from dust / liquids.</b>						
	X	X		IP67 protection cap for M12 female connector.	WI1000-M12FCAP1	
X			X	IP67 protection cap for M12 male connector.	WI1000-M12MCAP1	

**Important:** Please note that the cables are a standard type. They are not recommended for use in cable chains or where the cable is repeatedly bent. If this is required, use a special robot cable (2D or 3D cable). See also *Accessories*, page 415 where additional M12 connectors are shown.

## 4.8 Expansion Module MAC00-FP2/FP4

---

### 4.8.17 GSD file for the MAC00-FP2 and FP4

The GSD file must be used to configure the PLC or master controller used for the Profibus communication. The file is shown here but is also available on disc. Please contact your nearest JVL representative.

GSD file:

```
; COM PROFIBUS V 3.3, GSD'-Xport
; Time Stamp: 01/31/00, 12:36:39
#Profibus_DP
; <Unit-Definition-List>
GSD_Revision=1
Vendor_Name='JVL IND EL'
Model_Name='MAC00-FP'
Revision='0.0'
Ident_Number=0x06BC
Protocol_Ident=0
Station_Type=0
Hardware_Release='1.1'
Software_Release='1.2'
9.6_supp=1
19.2_supp=1
93.75_supp=1
187.5_supp=1
500_supp=1
1.5M_supp=1
3M_supp=1
6M_supp=1
12M_supp=1
MaxTsd_9.6=60
MaxTsd_19.2=60
MaxTsd_93.75=60
MaxTsd_187.5=60
MaxTsd_500=100
MaxTsd_1.5M=150
MaxTsd_3M=250
MaxTsd_6M=450
MaxTsd_12M=800
Implementation_Type='VPC3'
Bitmap_Device='DPLINK_'

; Slave-Specification:
Freeze_Mode_supp=0
Sync_Mode_supp=0
Auto_Baud_supp=1
Min_Slave_Intervall=1
Max_Diag_Data_Len=8
Modul_Offset=0
Slave_Family=0
OrderNumber='MAC00-FPx'
```

## 4.8 Expansion Module MAC00-FP2/FP4

---

```
; UserPrmData: Length and Preset:
PrmText=1
Text(0)='Active low'
Text(1)='Active high'
EndPrmText

PrmText=2
Text(0)='Velocity = 0'
Text(1)='Passive mode'
EndPrmText

PrmText=3
Text(0)='Disabled'
Text(1)='Enabled'
EndPrmText

ExtUserPrmData=1 'IN1 Input level'
Bit(0) | 0-1
Prm_Text_Ref=1
EndExtUserPrmData

ExtUserPrmData=2 'IN2 Input level'
Bit(1) | 0-1
Prm_Text_Ref=1
EndExtUserPrmData

ExtUserPrmData=3 'IN3 Input level'
Bit(2) | 0-1
Prm_Text_Ref=1
EndExtUserPrmData

ExtUserPrmData=4 'IN4 Input level'
Bit(3) | 0-1
Prm_Text_Ref=1
EndExtUserPrmData

ExtUserPrmData=5 'NL Input level'
Bit(4) | 0-1
Prm_Text_Ref=1
EndExtUserPrmData

ExtUserPrmData=6 'PL Input level'
Bit(5) | 0-1
Prm_Text_Ref=1
EndExtUserPrmData

ExtUserPrmData=7 'Endlimit action'
Bit(0) 0 0-1
Prm_Text_Ref=2
EndExtUserPrmData

ExtUserPrmData=8 'Input I Action'
Unsigned8 0 0-255
EndExtUserPrmData
```

## 4.8 Expansion Module MAC00-FP2/FP4

---

```
ExtUserPrmData=9 'Input 2 Action'  
Unsigned8 0 0-255  
EndExtUserPrmData  
  
ExtUserPrmData=10 'Input 3 Action'  
Unsigned8 0 0-255  
EndExtUserPrmData  
  
ExtUserPrmData=11 'Input 4 Action'  
Unsigned8 0 0-255  
EndExtUserPrmData  
  
ExtUserPrmData=12 'Input debounce'  
Bit(1) 0 0-1  
Prm_Text_Ref=3  
EndExtUserPrmData  
  
ExtUserPrmData=13 'Input noise filter'  
Bit(2) 0 0-1  
Prm_Text_Ref=3  
EndExtUserPrmData  
  
Max_User_Prm_Data_Len=15  
User_Prm_Data_Len=15  
User_Prm_Data=0x0,0x3F,0x0,0,0,0,0,0,0,0,0,0,0,0,0  
  
Ext_User_Prm_Data_Const(0) = 0x0,0x3F,0x0,0,0,0,0,0,0,0,0,0,0,0,0  
Ext_User_Prm_Data_Ref(1)=1  
Ext_User_Prm_Data_Ref(1)=2  
Ext_User_Prm_Data_Ref(1)=3  
Ext_User_Prm_Data_Ref(1)=4  
Ext_User_Prm_Data_Ref(1)=5  
Ext_User_Prm_Data_Ref(1)=6  
Ext_User_Prm_Data_Ref(2)=7  
Ext_User_Prm_Data_Ref(2)=12  
Ext_User_Prm_Data_Ref(2)=13  
Ext_User_Prm_Data_Ref(3)=8  
Ext_User_Prm_Data_Ref(4)=8  
Ext_User_Prm_Data_Ref(5)=8  
Ext_User_Prm_Data_Ref(6)=9  
Ext_User_Prm_Data_Ref(7)=9  
Ext_User_Prm_Data_Ref(8)=9  
Ext_User_Prm_Data_Ref(9)=10  
Ext_User_Prm_Data_Ref(10)=10  
Ext_User_Prm_Data_Ref(11)=10  
Ext_User_Prm_Data_Ref(12)=11  
Ext_User_Prm_Data_Ref(13)=11  
Ext_User_Prm_Data_Ref(14)=11  
  
; <Module-Definition-List>  
Module='MAC00-FP' 0x13,0x10,0x10,0x10,0x10,0x10,0x23,0x20,0x20,0x20,0x20,0x20  
EndModule
```

## 4.9 Expansion Module MAC00-FS1/FS4



### 4.9.1 High speed serial RS485 module MAC00-FS1 and FS4 Introduction

The MAC00-FS1 and FS4 are used for high speed RS485 communication typically in multi axis systems. They are capable of running at Baud-rates up to 460kbit. All the registers of the MAC motor can be read and written.

The modules includes a few inputs and outputs, 2 of which can be defined as end-limit inputs. These can be read from the RS485 interface.

The MAC motor is controlled by writing to the internal registers in the motor.

The expansion modules MAC00-FS1 and FS4 can be mounted on the standard MAC motors MAC50, MAC95, MAC140, MAC141, MAC400-800.

Both modules offer the same functions but with the following hardware differences:

Type	Protection class	Connectors		
		I/O.	Power supply	RS232/485
<b>MAC00-FS1</b>	IP42	DSUB 15 pole	3 pole Phoenix	DSUB 9 pole
<b>MAC00-FS4</b>	IP67/IP65*	M12 connector 8pin male and female	M12 connector 5pin male	M12 connector 5pin female

Note\*: IP65 on MAC400-800

Both modules are delivered without any cables as standard. Optional the MAC00-FS4 module can be delivered with cables in 5 or 20m length. The pages in the first part of this section concern the common features of both modules. Please consult the last pages in this section to see specific information about each module such as example connection diagrams.

# 4.9 Expansion Module MAC00-FS1/FS4

## 4.9.2 General description MAC00-FS1

The MAC00-FS1 expansion module is an industrial interface that mates with the standard MAC motor and offers a number of feature enhancements, including:

- Standard 9-pin D-SUB connectors for additional reliability.
- Addition of a Zero switch input for locating a mechanical zero point of the actuator when used in position-related modes.
- Pluggable screw terminal connector for power supply and Zero switch.
- LEDs to indicate: O1 and O2 output status, Zero switch (analogue input) status. Input power status.
- Full RS232 and RS485 protocol support for use with standard 9-pin DSUB.
- Sourcing (PNP) outputs for status signals O1 and O2 instead of sinking (NPN).

The following illustration shows all the connectors on the MAC00-FS1 module.

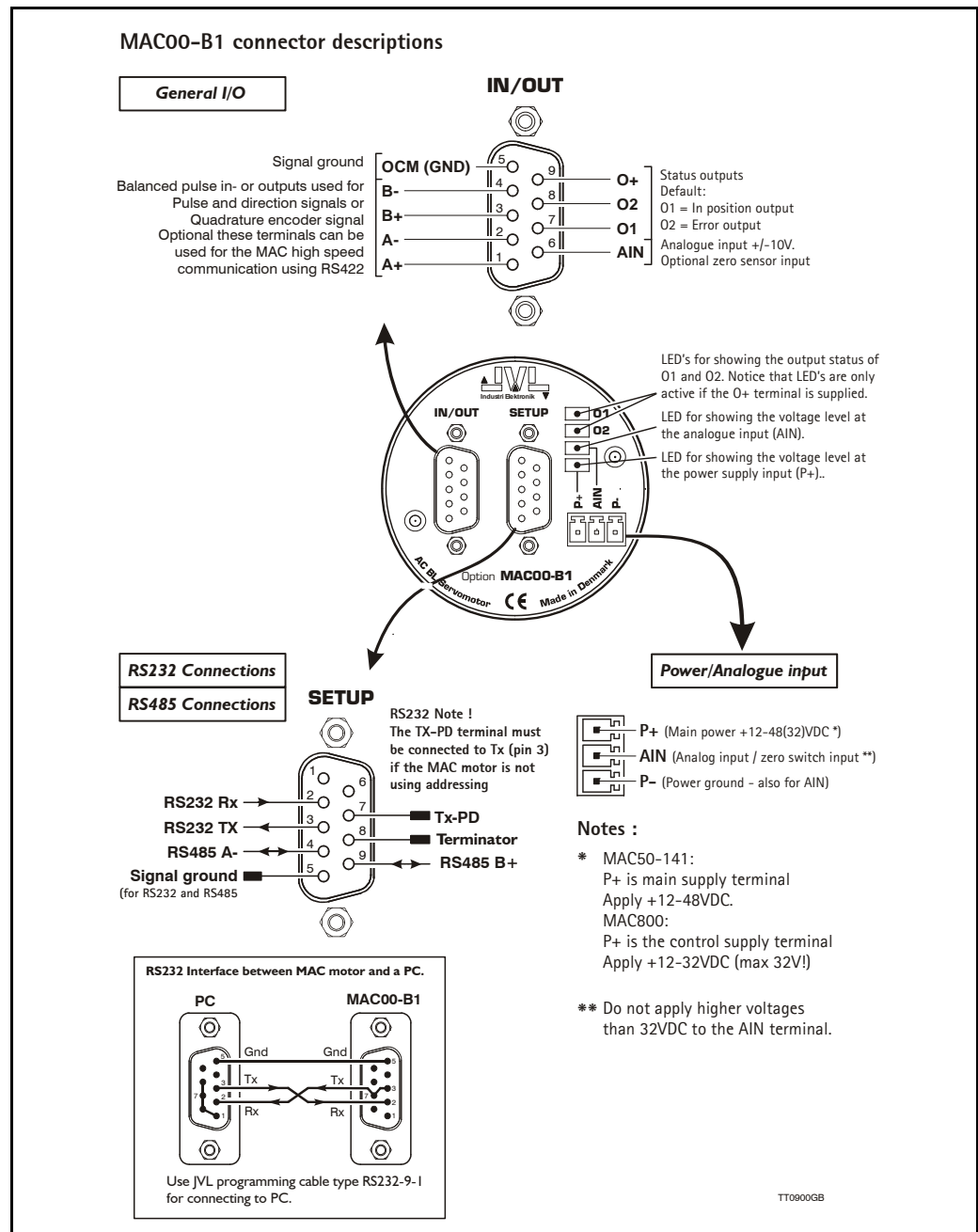

## 4.9 Expansion Module MAC00-FS1/FS4

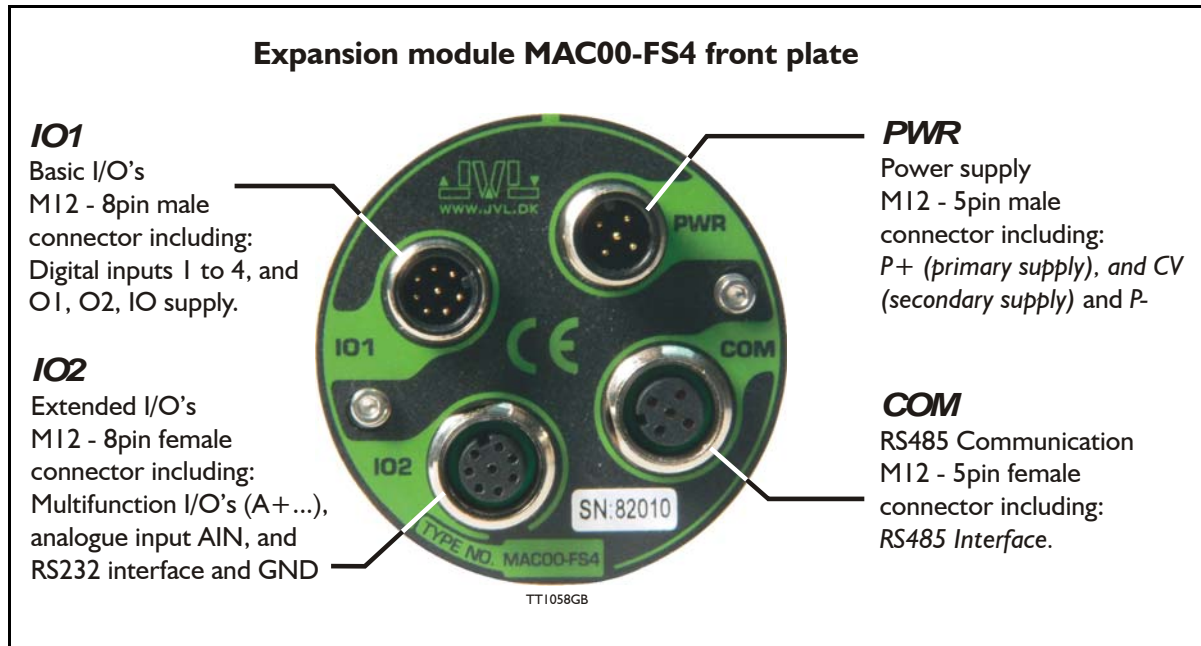

### 4.9.3 Expansion MAC00-FS4 hardware description

The MAC00-FS4 offers a IP67 on MAC050-141 protection and M12 connectors which makes it ideal for automation applications where no additional protection is desired. The M12 connectors offers a solid mechanical protection and are easy to operate.

The connector layout:

<b>“PWR” - Power input. M12 - 5pin male connector</b>				
Signal name	Description	Pin no.	JVL Cable WI1000- M12F5T05N	Isolation group
P+	Main supply +12-48VDC. Connect with pin 2 *	1	Brown	1
P+	Main supply +12-48VDC. Connect with pin 1 *	2	White	1
P-	Main supply ground. Connect with pin 5 *	3	Blue	1
CV	Control voltage +12-48VDC.	4	Black	1
P-	Main supply ground. Connect with pin 3 *	5	Grey	1
* Note: P+ and P- is each available at 2 terminals. Make sure that both terminals are connected in order to split the supply current in 2 terminals and thereby avoid an overload of the connector.				
<b>“COM” - Interface RS485. M12 - 5pin female connector</b>				
Signal name	Description	Pin no.	JVL Cable WI1000M12 M5T05N	Isolation group
-	Leave open	1	Brown	1
-	Leave open	2	White	1
RS485 A-	RS485 interface positive terminal. Leave open if unused	3	Blue	2
RS485 B+	RS485 interface negative terminal. Leave open if unused	4	Black	2
GND	Interface ground	5	Grey	2

(Continued next page)



## 4.9 Expansion Module MAC00-FS1/FS4

(Continued from last page)

<b>"IO1" - Basic I/O's. M12 - 8pin male connector.</b>				
<b>Signal name</b>	<b>Description</b>	<b>Pin no.</b>	<b>JVL Cable WI1000-M12 F8T05N</b>	<b>Isolation group</b>
IN1	Digital input 1	1	White	3
IN2	Digital input 2	2	Brown	3
IN3	Digital input 3	3	Green	3
IN4	Digital input 4	4	Yellow	3
O1	Digital output 1 - PNP output Output current maximum 25mA	5	Grey	3
O2	Digital output 2 - PNP output Output current maximum 25mA	6	Pink	3
O+	Output supply +5-32VDC. Used for O1-4. Not used/necessary for using IN1-8	7	Blue	3
IO-	I/O ground. Used for IN1-8 and O1-4.	8	Red	3
<b>"IO2" - Extended I/O's. M12 - 8pin female connector.</b>				
<b>Signal name</b>	<b>Description</b>	<b>Pin no.</b>	<b>JVL Cable WI1000-M12 M8T05N</b>	<b>Isolation group</b>
AIN1	Analogue input +/-10V. Directly connected to basic motor	1	White	1
Tx	RS232 interface - transmit output	2	Brown	1
Rx	RS232 interface - receive input	3	Green	1
GND	RS232 Ground - also used with analogue input	4	Yellow	1
A+	Multifunction I/O terminal A+. Maximum 5V !	5	Grey	1
A-	Multifunction I/O terminal A-. Maximum 5V !	6	Pink	1
B+	Multifunction I/O terminal B+. Maximum 5V !	7	Blue	1
B-	Multifunction I/O terminal B-. Maximum 5V !	8	Red	1
<b>Cable Screen</b>				
Some standard cables with M12 connector offers a screen around the cable. This screen is at some cables fitted to the outer metal at the M12 connector. When fitted to the MAC00-FS4 modul this means that the screen will get in contact with the complete motor housing and thereby also the power ground (main ground).				
<b>Isolation groups</b>				
The MAC00-FS4 offers optically isolation at the digital inputs and outputs (IN1-4 and O1-2). In the table is shown a number for each pin. This number refers to which isolation group the terminal is connected to. Isolation group 1 means that the terminals refers to the main ground (P-, GND and the motor housing). Isolation group 2 means that the terminals refer only to the RS485 interface. Isolation group 3 means that the terminals refer to the I/O ground (IO-).				

# 4.9 Expansion Module MAC00-FS1/FS4

**MAC00-FS4 Dip switch settings**

**Dip 1-6 - I/O setup**

Makes it possible to share I/O signals in the same cable

Function:

- 1: Connect **CV** to **O+**
- 2: Connect **P-** to **IO-**
- 3: Connect **IN3** to **AIN**
- 4: Connect **IN4** to **AIN**
- 5: Connect **O1** to **AIN**
- 6: Connect **O2** to **AIN**

To activate the mentioned connection please set the actual switch to position "ON"

SW1B default settings =

- 1, 2 and 4 set in position "ON"
- 3, 5 and 6 set in position "OFF"

Mini dip-switch

OFF ← ON

**SW1B**

Rear side of the MAC00-FS4 expansion module

**Dip 1-2 - Line termination**

Both set to ON = Term. enabled

Both set to OFF = Term. disabled

SW2 default settings =

Both switches in position "OFF"

Mini dip-switch

OFF ← ON

**SW2**

**Dip 1-10 - For Future use**

SW1 default settings = all set in position "ON"

**Dip switch location on the MAC00-FS4 Expansion module**

Dip Switches placed on the rear side of the module

Mini dip-switch

OFF ← ON

**SW1A**







Module seen from rear side

TTI017GB

## 4.9 Expansion Module MAC00-FS1/FS4

### 4.9.4 Cables for the MAC00-FS4

Following cables equipped with M12 connector can be supplied from JVL.

MAC00-FS4 Connectors				Description	JVL Order no.	Picture
"IO1" 8pin Male	"IO2" 8pin Female	"COM" 5pin Female	"PWR" 5pin Male			
	X			RS232 Interface cable. Connects directly from MAC00-R4 to PC Length: 5m (197 inch)	RS232-M12-1-5-8	
			X	Cable (Ø5.5mm) with M12 female 5-pin connector loose wire ends 0.35mm <sup>2</sup> (22AWG) and foil screen. Length: 5m (197 inch)	WI1000-M12F5T05N	
			X	Same as above but 20m (787 inch)	WI1000-M12F5T20N	
		(X) Note1		Cable with M12 male 5-pin connector loose wire ends 0.35mm <sup>2</sup> (22AWG) and screen. Length: 5m (197 inch)	WI1000-M12M5T05N	
		(X) Note1		Same as above but 20m (787 inch)	WI1000-M12M5T20N	
X				Cable with M12 female 8-pin connector loose wire ends 0.22mm <sup>2</sup> (24AWG) and screen. Length: 5m (197 inch)	WI1000-M12F8T05N	
X				Same as above but 20m (787 inch)	WI1000-M12F8T20N	
	X			Cable with M12 male 8-pin connector loose wire ends 0.22mm <sup>2</sup> (24AWG) and screen. Length: 5m (197 inch)	WI1000-M12M8T05N	
	X			Same as above but 20m (787 inch)	WI1000-M12M8T20N	
<b>Protection caps. Optional if connector(s) needs to be protected from dust / liquids.</b>						
	X	X		IP67 protection cap for M12 female connector.	WI1000-M12FCAP1	
X			X	IP67 protection cap for M12 male connector.	WI1000-M12MCAP1	

Note 1: The illustrated cable is not twisted pair and is not recommended for noisy environment. We recommend to use a shielded twisted pair cable for noisy applications. Also it is recommended to use a metal type connector where the screen can be terminated to obtain optimal screening effect.

**Important:** Please notice that the cables are a standard type. It is not recommended to be used in cable chains or where the cable repeatable are being bended. If this is required use a special robot cable (2D or 3D cable). See also *Accessories*, page 415 where additional M12 connectors are shown.

## 4.10 Expansion module MAC00-P4/P5

Only MAC400-3000

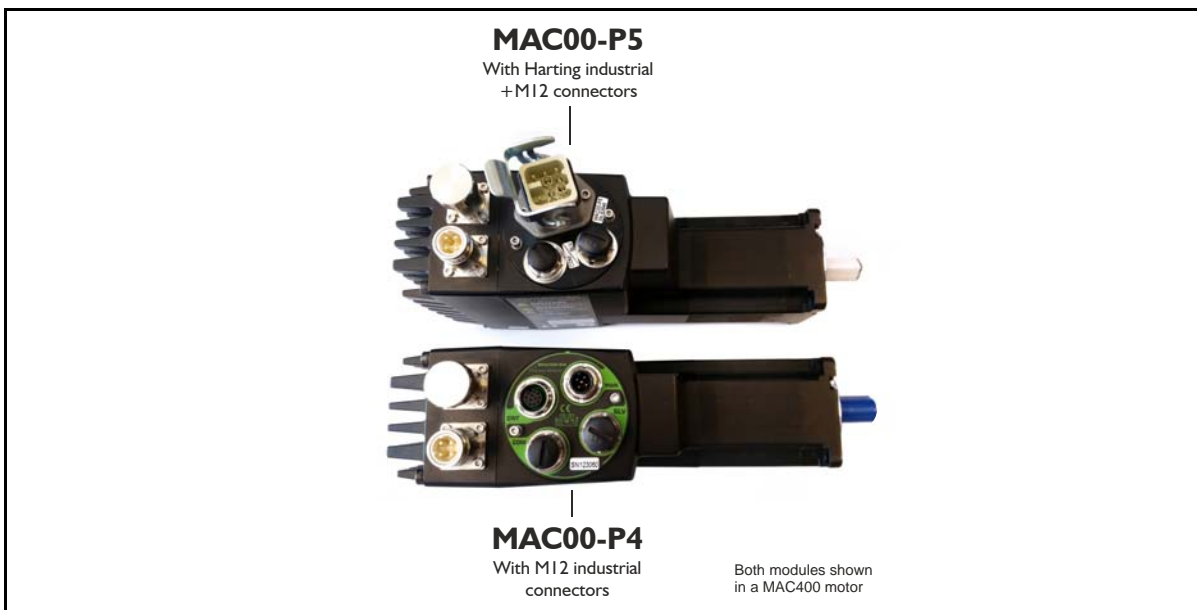

### 4.10.1 Expansion module MAC00-P4 and P5 — overall description.

Important !: please notice that this module will only function in MAC800 motors with a serial number greater than 85000. All MAC400 motors supports this module.

The MAC00-P4 and P5 is an expansion module for the integrated servomotors MAC400-3000. **Please notice that the module can NOT be used in the MAC050-141 since all I/Os will not be supported.**

The module is intended to be used for control application requiring an analogue 4-20mA interface to a master controller.

The interface is consisting of a 4-20mA input to control the motor position and a 4-20mA output to indicate the actual position. Both offers full galvanic isolation from other electrical circuitries inside the motor and also in between.

An output is also available to indicate if any error has occurred that prevent the motor from doing the intended operation. This output is also galvanic isolated.

If a second motor need to function as a slave the MAC00-P4 and P5 modules also offers this possibility. A high speed communication interface makes it possible to handle a secondary motor configured as "slave" which means that the communication protocol always makes sure that the slave follows the master motor. In case of an error in either the slave or master any further motion is stopped in both motors.

The modules contain no intelligence (microprocessor) meaning that all functions are controlled via the basic motor in which the module is installed.

The MAC00-P4 and P5 expansion modules offers an industrial interface (M12 connectors + Harting) and a number of feature enhancements, including:

- Standard M12 and Harting connectors for optimum reliability
- 4-20mA analogue input. Resolution 16 bit (65535 steps). Galvanic isolated.
- 4-20mA analogue output. Resolution 16 bit (65535 steps). Galvanic isolated.
- Error output. Galvanic isolated.
- Communication interface to slave motor (includes +24V power to the slave motor)
- Optical isolated RS232 communication to PC or external master
- Optical isolated RS485 to slave motor (Closed protocol)
- Full RS232 protocol support for use with standard serial cable.
- RS232 Communication interface to a PC for setup and monitoring use.
- Supply input for the control section in the motor. Is also used to the slave motor if present.

## 4.10 Expansion module MAC00-P4/P5

Only MAC400-3000

### 4.10.2 Overall hardware description

All internal and external main connections can be seen in the illustration below.

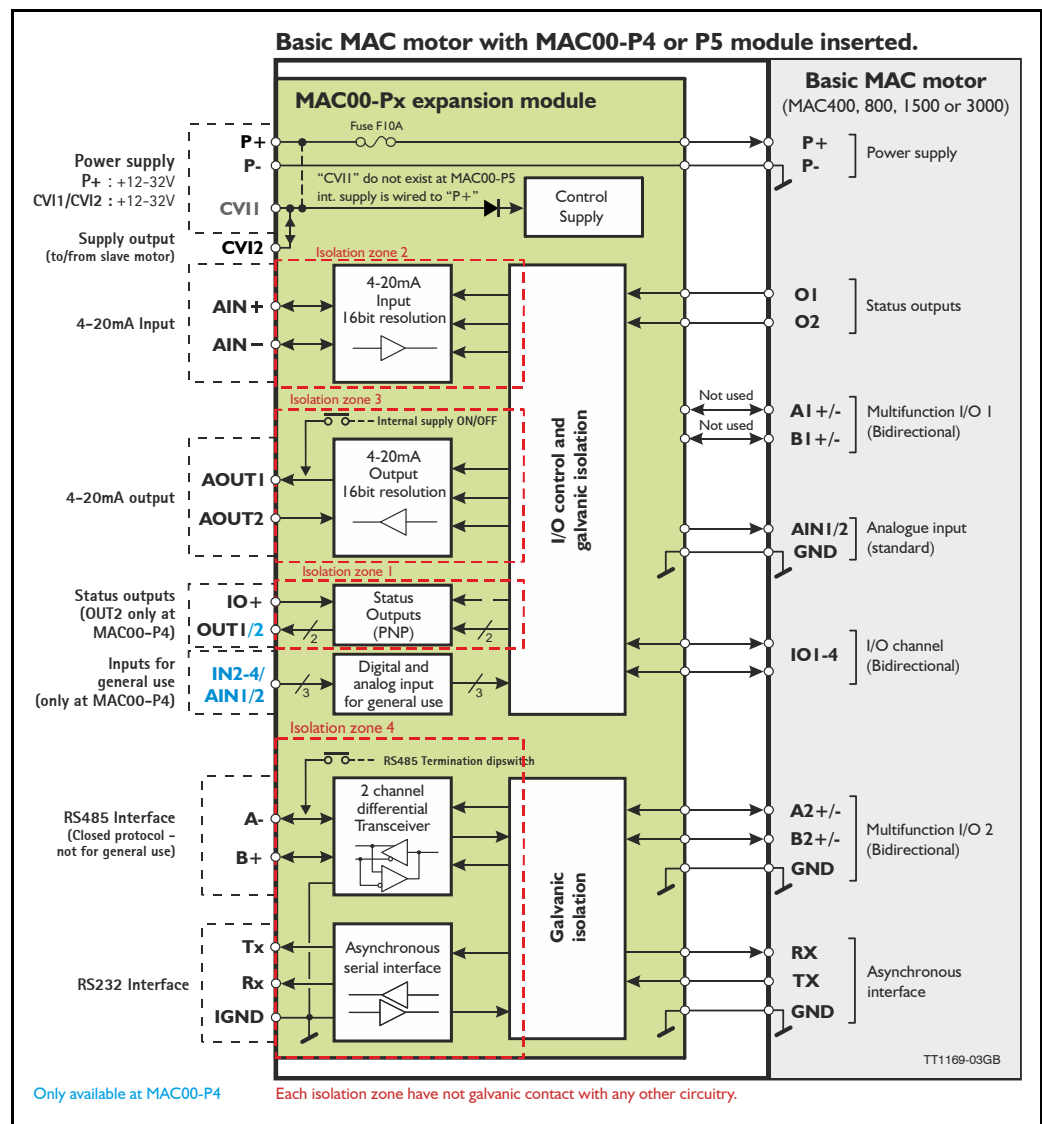

### 4.10.3 General hardware description

The MAC00-Px module offers the following external connections.

- **Power supply (P+/P-/CVI1/CVI2)**  
 These terminals are used for the main supply of the motor. A voltage between +12 and 32VDC must be connected to P+ and optionally CVI1 (CVI1 only exist at the MAC00-P4 module). CVI2 is hardwired to CVI1 and is intended to be used for supplying a slave motor or receiving supply from a master motor. This simplifies the cable connections since it is available in the same connector as the RS485 slave communication.
- **Status outputs (OUT1, OUT2 and IO+)**  
 OUT1 is an error output which indicates when an error exist. OUT2 is for future options. IO+ is the overall supply of the outputs and must be applied with 5-32VDC. The outputs are PNP (source) outputs. The outputs are galvanic isolated from all other terminals and circuits.

## 4.10 Expansion module MAC00-P4/P5 Only MAC400-3000

- **4-20mA Analogue input (AIN+ and AIN-)**  
The analogue input is read by the motor and will typically be used with the motor set in “Analogue to position mode”. In this configuration the motor position will follow the analogue input proportional in a user defined working range.  
The analogue input has a resolution of 16 bit corresponding to the rang 0 to 20mA divided into 65536 steps. The input is galvanic isolated from all other terminals and circuits.
- **4-20mA Analogue output (AOUT+ and AOUT-)**  
The analogue output is monitoring the actual position when the motor is set in “Analogue to position mode”. In this configuration the output value will be from 4 to 20mA proportional to the actual motor position in a user defined working range.  
The analogue output has a resolution of 16 bit corresponding to the rang 4 to 20mA divided into 65536 steps. The output is galvanic isolated from all other terminals and circuits.
- **RS485 Interface (A-, B+ and IGND)**  
Serial balanced interface for connection to a slave motor.
- **RS232 Interface (Rx, Tx and IGND)**  
Serial unbalanced interface for connection to a PC or a controller. All registers/parameters in the motor can be monitored or changed. RS232 is not recommended for long distances (> 10m).

The MAC motor uses “binary” communication protocol which makes it possible to access all the internal registers. Please consult *MacTalk communication, page 378* for further details.

### 4.10.4 Hardware overview

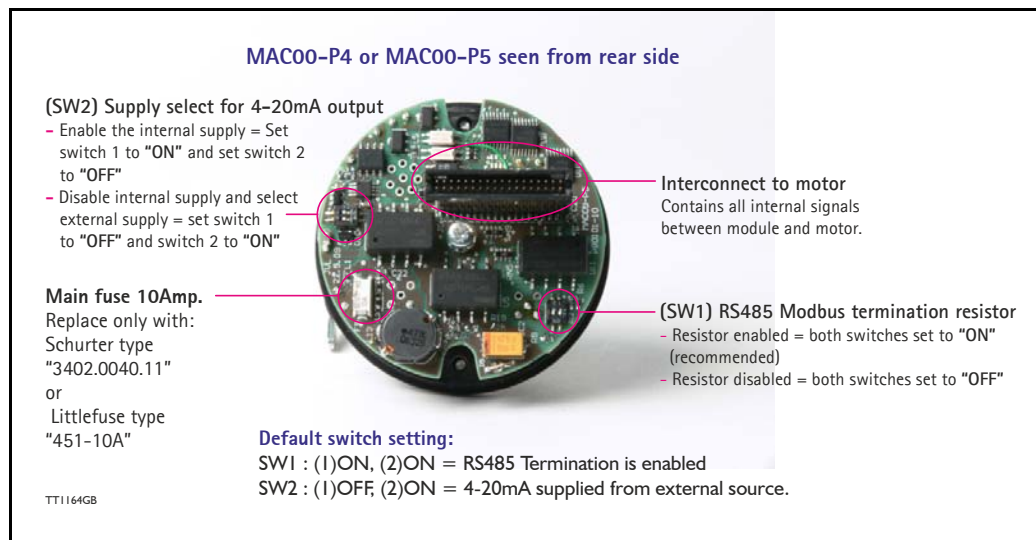

## 4.10 Expansion module MAC00-P4/P5

Only MAC400-3000

### 4.10.5 General power supply description

The MAC00-P5 module can only be used in the MAC400 motor. The diagram below shows how to connect power to a MAC400 motor mounted with a MAC00-P5. Please notice that the voltage connected to CV11 and P+ (only -MAC00-P4) must stay in the range +12-32VDC. Precautions must therefore be taken if the system also contains MAC50, 95, 140 or 141 which may require 48VDC in order to reach maximum motor speed.

See also the general power supply description *Power Supply*, page 87.

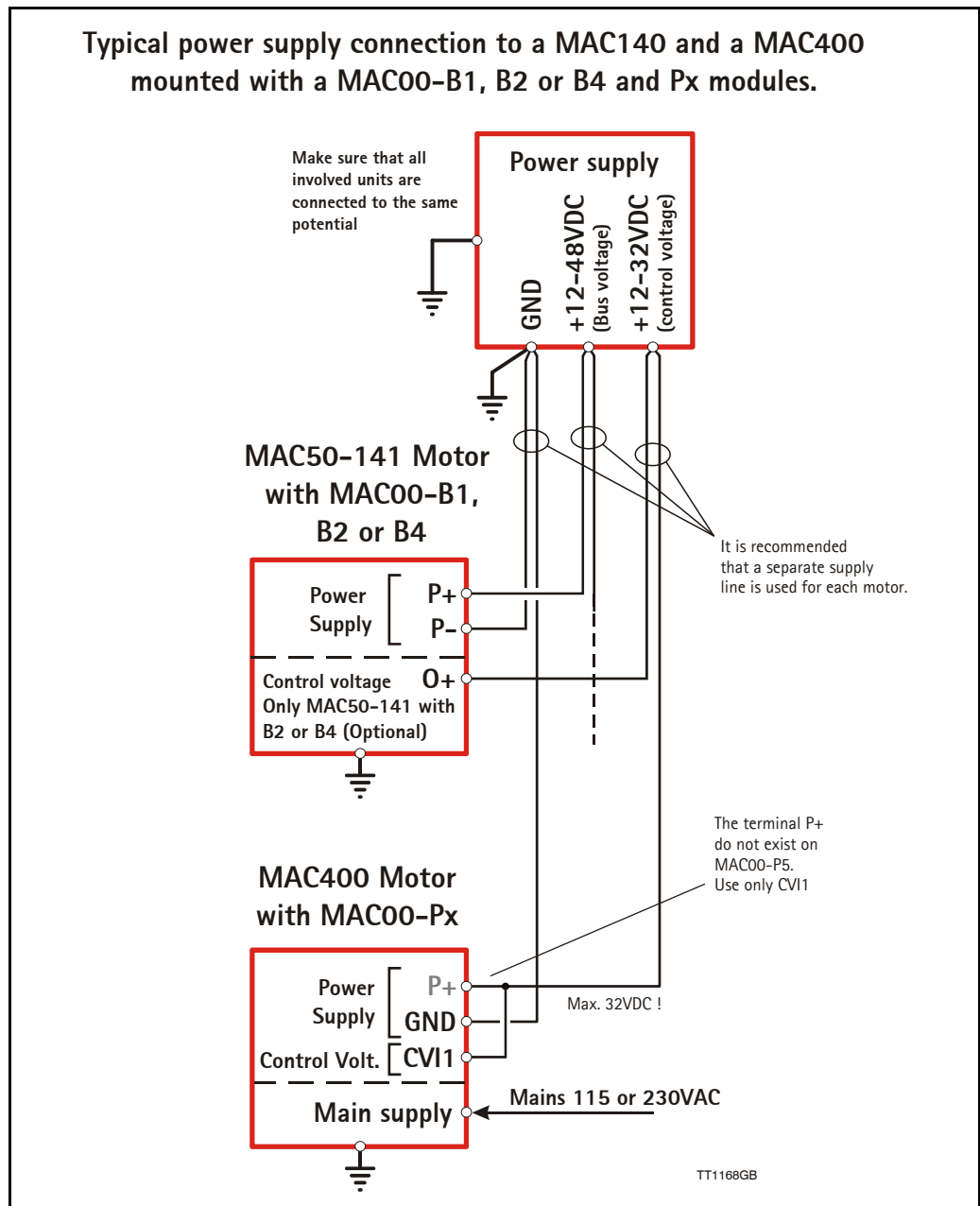

## 4.10 Expansion module MAC00-P4/P5 Only MAC400-3000

### 4.10.6 RS232 - General description when using the MAC00-P4/5 module

The RS232 interface is considered the main interface to the motor when the motor is set up using the MacTalk windows software from a PC or from any kind of controller using a RS232 interface.

*Note: The basic MAC motor does not fully support RS232 since the interface signals are only 5V levels. See also the basic description - Serial interface, page 109.*

When connecting the RS232 interface to a PC or controller, the following rules must be followed:

- 1 Only one motor can be connected at the interface line.
- 2 Use screened cable.
- 3 Ensure that GND is also connected.
- 4 Ensure that all units have a proper connection to safety ground (earth) in order to refer to the same potential.
- 5 The RS232 interface cable length should not exceed 10 metres.

#### Connectors:

To see the specific connector pin-out please see the chapter

- Expansion MAC00-P4 connector description, page 285 or
- Expansion MAC00-P5 connector description, page 288

A finished RS232 cable also exist. Please see

- Cables for the MAC00-P4, page 287 or
- Cables for the MAC00-P5, page 290

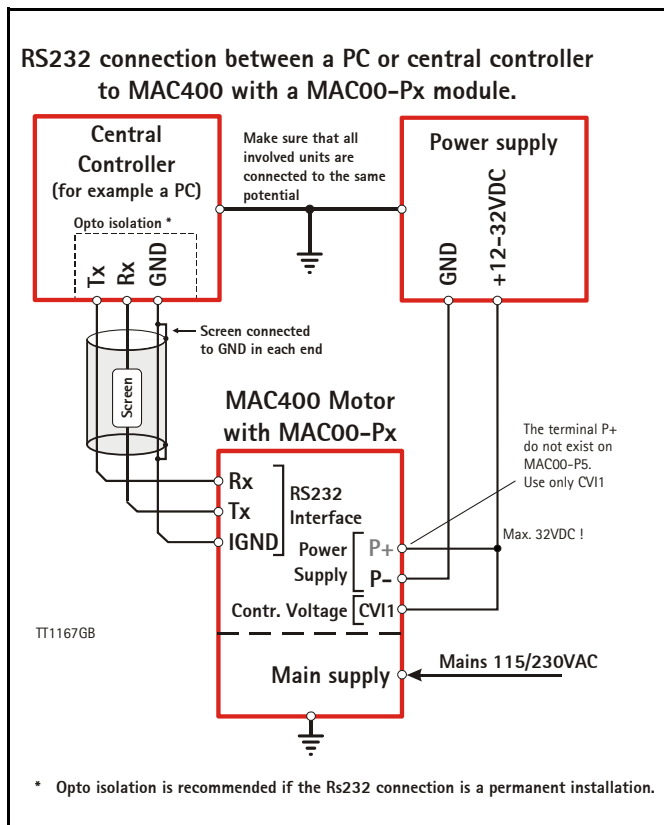



## 4.10 Expansion module MAC00-P4/P5

Only MAC400-3000

### 4.10.7 How to connect the 4-20mA output

The 4-20mA output (terminal AOUT1 and AOUT2) can be configured in 2 ways.

- The MAC00-P4 or P5 module provide the supply to the 4-20mA signal  
Dip switch setting as seen below: 1 = ON and 2 = OFF
- The receiver of the 4-20mA signal from the MAC00-P4 or P5 module takes care of the supply to produce the 4-20mA signal.  
Dip switch setting as seen below: 1 = OFF and 2 = ON.

The dip switch is located on the rear part of the circuit board.

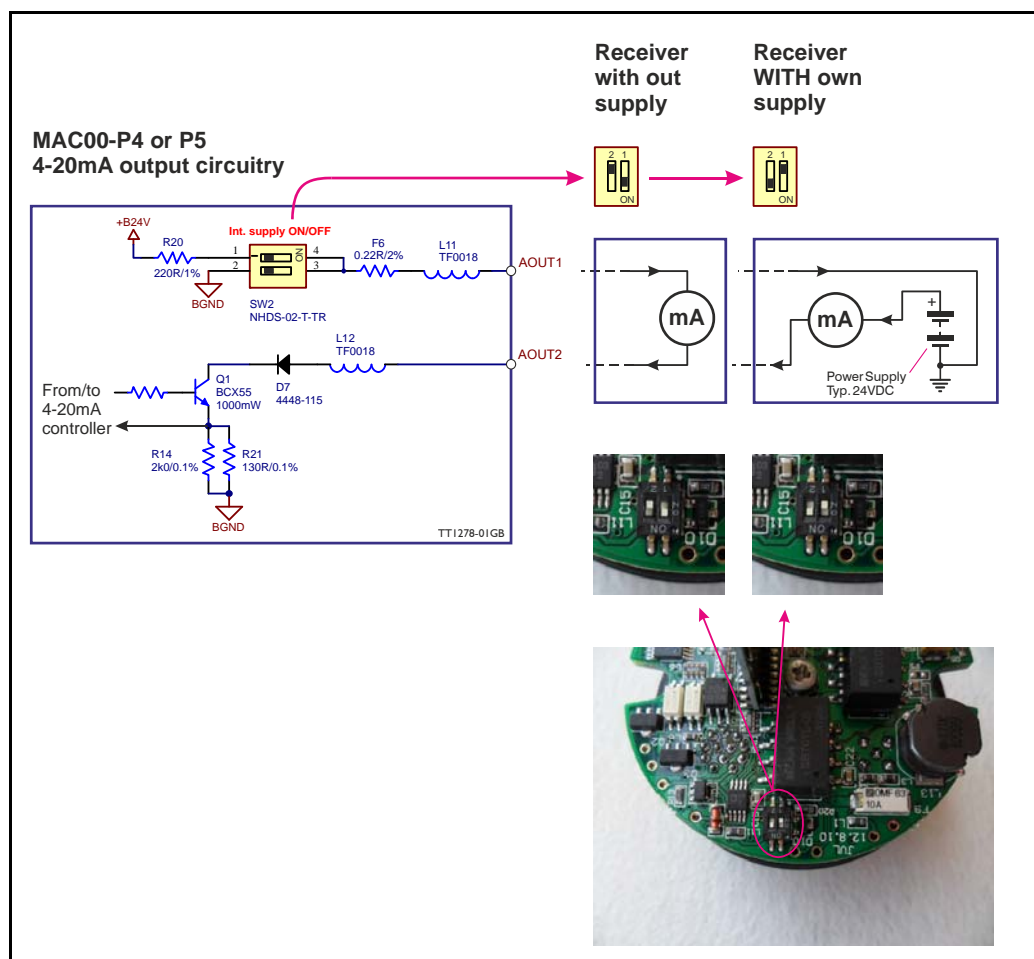

# 4.10 Expansion module MAC00-P4/P5

Only MAC400-3000

## 4.10.8 Basic setup of the "Master" motor.

Following steps must be followed

1. Enter the program "MacTalk" version 1.60 or newer.
2. Set the motor in "Analogue to position" mode in order to control the actual motor position by an analogue input.
3. Max velocity, Acceleration, torque etc. must be adjusted for the actual application. This can be done now or at any other time.
4. At the "Advanced" tab select "Paired Master" under Modbus setup.
5. Select AIN3 as analogue input in order to use the 4-20mA input at the MAC00-P4/5 module instead of the default input (AIN1).

**Setting up the Master motor in MacTalk**

Select **Analogue to position** mode.

Setup the desired max velocity and acceleration. Torque and Load may also need a different setting compared to the default setup.

Select **Paired Master** in the Modbus setup.

Select **ANINP3** in as process input - this is the 4-20mA input at the P4/5 module.

## 4.10 Expansion module MAC00-P4/P5 Only MAC400-3000

(Master setup continued)

- Go to the "Registers" tab and define the desired working range by entering a number in "P2" after following formulars

**For linear applications (spindle actuator):**  $P2 = WR / SP * GR * CPR * 32 / 52428$

Notes:

WR = Working range in mm

SP = Spindle pitch (linear motion per spindle revolution)

GR = Gear ratio between motor and spindle (if any). Set to 1.00 if none

CPR = Counts per motor revolution (MAC400, 402, 1500 and 3000: 8192 CPR / MAC800: 8000 CPR).

**For rotary applications:**  $P2 = WR / 360 * GR * CPR * 32 / 52428$

Notes:

WR = Working range in degrees

GR = Gear ratio between motor and output shaft (if any) - set to 1.00 if none

CPR = Counts per motor revolution (MAC400, 402, 1500 and 3000: 8192 CPR / MAC800: 8000 CPR).

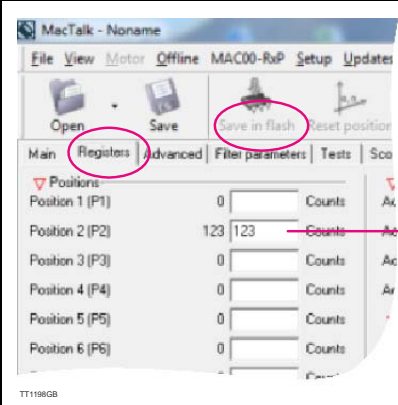

**Setting up the Master motor in MacTalk**

The calculated working range constant is typed in here.

Finally remember to «Save in flash» in order to save all the settings permanent in the motor.

### 4.10.9 Basic setup of the "Slave" motor.

If a second motor with a synchronous movement is needed the MAC00-P4/5 offers the possibility to connect 2 MAC motors in a master/slave configuration.

The 5pin M12 male connector located at the MAC00-P4/5 is the master/slave connector. By connecting the 5 pins in the master motor to the equivalent pins in the slave motor all communication and also 24V supply is taken care of in the slave motor (see supply options at previous page).

Beside these connections only 115/230VAC need to be supplied the slave motor.

*Continued next page*

## 4.10 Expansion module MAC00-P4/P5 Only MAC400-3000

If a slave motor is connected to the master the slave needs to be setup in order to establish permanent communication with the master motor.

Please following these steps to setup the slave motor

1. Enter the program “MacTalk” version 1.50 or newer.
2. At the “Advanced” tab select “Paired Slave” under Modbus setup.
3. Set the startup mode to “Position”-mode. By doing this the motor will start to follow the position of the master motor.
4. It is recommended to set the “max velocity” and “acceleration” to appropriate high values since they can cause a limitation in the motion of the slave compared to the master.
6. After changing relevant parameters please remember to save the changes permanent in the motor by pressing “Save in flash”.
7. It may be needed to cycle the 24V supply for both motors in order to establish full synchronization between the 2 motors.

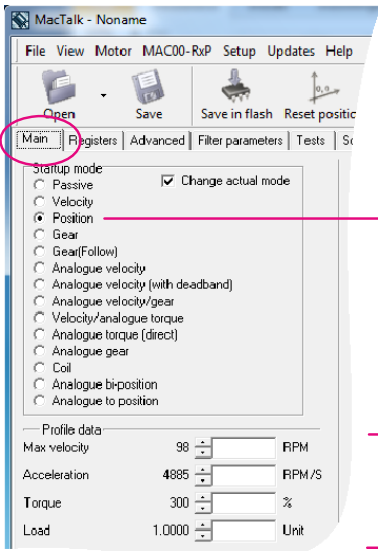

The screenshot shows the MacTalk software interface. The 'Advanced' tab is selected. Under 'Startup mode', 'Position' is selected with a radio button. Below this, there are fields for 'Profile data': Max velocity (98 RPM), Acceleration (4885 RPM/S), Torque (300 %), and Load (1.0000 Unit). The 'Main' tab is also visible in the background.

**Setting up the Slave motor in MacTalk**

Select **Position** mode.

Setup the desired max velocity and acceleration. Torque and Load may also need a different setting compared to the default setup.

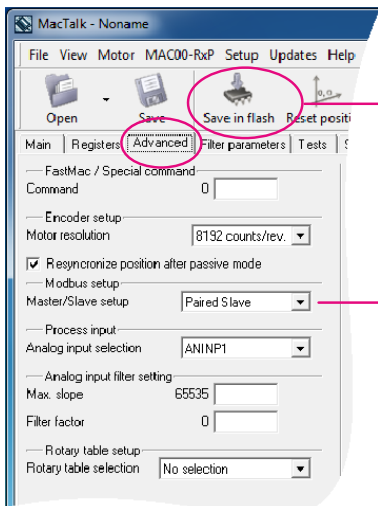

The screenshot shows the MacTalk software interface. The 'Advanced' tab is selected. Under 'Modbus setup', 'Paired Slave' is selected in the 'Master/Slave setup' dropdown menu. The 'Save in flash' button is circled in red.

Finalize the setup by pressing the «Save in Flash» button.

Select **Paired Slave** in the Modbus setup.

# 4.10 Expansion module MAC00-P4/P5

Only MAC400-3000

## 4.10.10 Master/slave application example.

The illustration below shows exactly how 2 motors installed with a MAC00-P4 module can be connected in a master/slave coupling using the cable JVL type: W11005-M12F5TF5T03P which contains an internal supply for the slave and a RS485 connection.

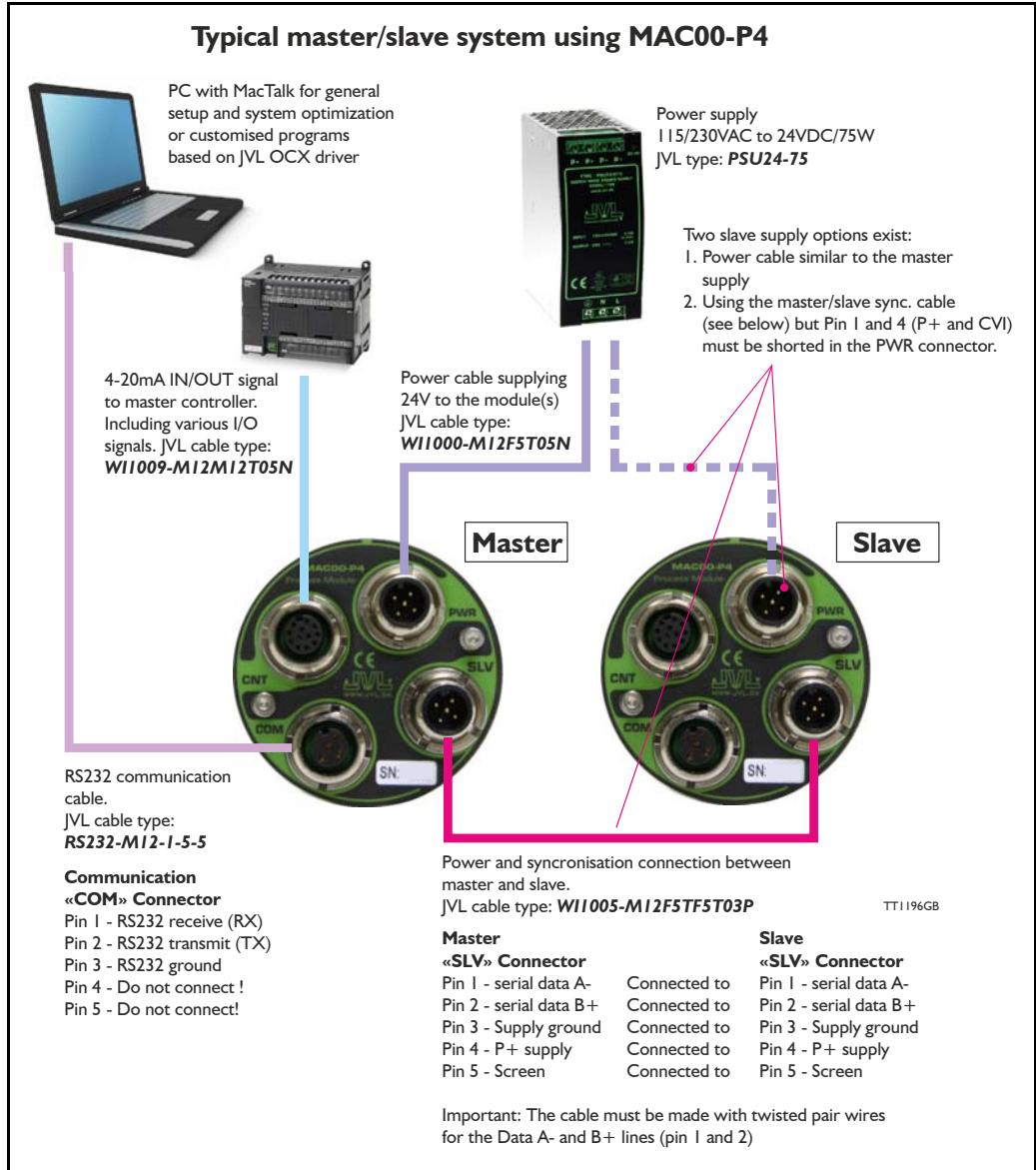

## 4.10 Expansion module MAC00-P4/P5

Only MAC400-3000

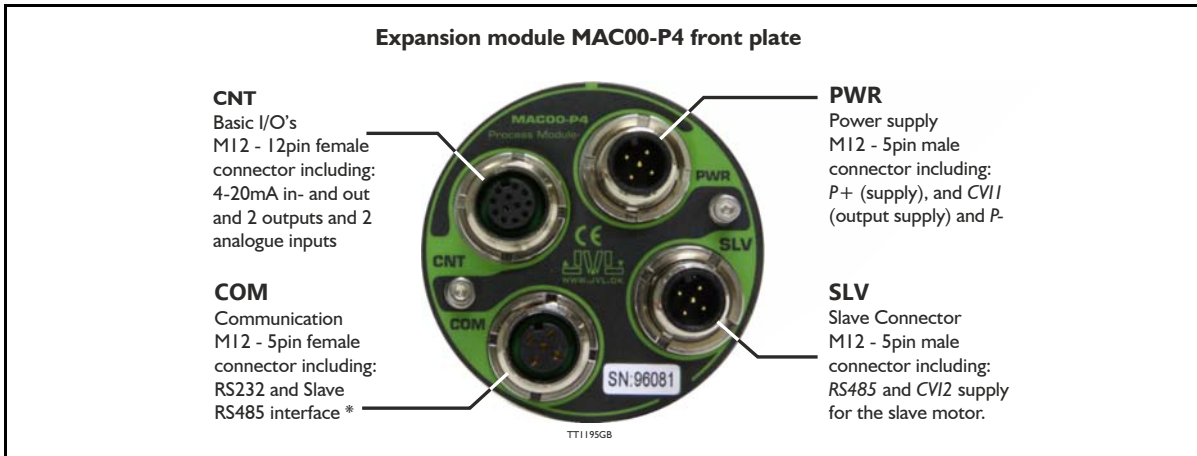

### 4.10.11 Expansion MAC00-P4 connector description

The MAC00-P4 offers IP65 protection when used in the MAC400, 402, 800, 1500 or MAC3000 and M12 connectors which makes it ideal for process control and automation applications where no additional protection is desired. The M12 connectors offer solid mechanical protection and are easy to unplug compared to modules with cable glands or DSUB connectors.

The connector layout:

"PWR" - Power input. M12 - 5pin male connector				
Signal name	Description	Pin no.	JVL Cable W11000-M12F5T05N	Isolation group
P+	Main supply +12-48VDC. Connect with pin 2 *	1	Brown	1
P+	Main supply +12-48VDC. Connect with pin 1 *	2	White	1
P-	Main supply ground. Connect with pin 5 *	3	Blue	1
CV11	Output supply / Control voltage +12-32VDC.	4	Black	1
P-	Main supply ground. Connect with pin 3 *	5	Grey	1

\* Note: P+ and P- are each available at 2 terminals. Make sure that both terminals are connected in order to split the supply current in 2 terminals and thereby avoid an overload of the connector.

(Continued next page)

## 4.10 Expansion module MAC00-P4/P5

Only MAC400-3000

<b>"CNT" - Control I/O. M12 - 12pin female connector</b>				
Signal name	Description	Pin no.	JVL Cable W11009- M12M12T05N	Isolation group
AIN+	4-20mA input. Positive terminal	3	White	2
AIN-	4-20mA input. Negative terminal	1	Brown	2
AOUT1	4-20mA output. Positive terminal. Apply 7 to 24V to this terminal if internal AOUT supply is disabled.	9	Red	3
AOUT2	4-20mA output. Negative terminal.	2	Blue	3
O+	Supply term. to the OUT1 and 2 circuitry. Apply 5 - 32VDC	11	Grey/Pink	1
OUT1	Output 1 - Default : Error output. PNP ouput.	6	Yellow	1
OUT2	Output 2. PNP ouput.	4	Green	1
CVI1	Control supply input +12-28VDC. Consumption typical 350mA @ 24VDC and 700mA @24VDC if a slave motor is connected. At <b>MAC00-P4</b> the CVI1 is hardwired to the CVI terminal (pin 4) at the power connector. At <b>MAC00-P5</b> the CVI1 is not present but CVI1 is internally hardwared to P+.	12	Red/Blue	0
P-	Main ground to be used with CVI1 and IN2-4.	10	Violet	0
IN2 / AIN1	General digital input and analogue input 1 Notice that analogue input 1 is used for <i>Zero search</i>	5	Pink	0
IN3 / AIN2	General digital input and analogue input 2	8	Grey	0
IN4	General digital input	7	Black	0

\* Note: Isolation group indicate which terminals/circuits that a galvanic connected to each other. In other words group 1, 2, 3 and 4 are all fully independantly isolated from each other. Group 0 correspond to the housing of the motor which may also be connected to earth via the 115/230VAC power inlet.

<b>"COM" - Communication connector - M12 - 5pin female connector.</b>				
Signal name	Description	Pin no.	JVL Cable "RS232-M12-1- 5-5"	Isolation group (See note)
RS232: RX	RS232 interface. Receive terminal Leave open if unused.	1	Brown	4
RS232: TX	RS232 interface. Transmit terminal Leave open if unused.	2	White	4
IGND	Ground intended to be used together with the other signals in this connector.	3	Blue	4
RS485: A-	RS485 Modbus *. Leave open if unused	4	Black	4
RS485: B+	RS485 Modbus *. Leave open if unused	5	Grey	4

<b>"SLV" - Slave connector - M12 - 5pin male connector</b>				
Signal name	Description	Pin no.	JVL Cable "W11005-M12- F5TF5T03P"	Isolation group (see note)
RS485 A-	RS485 Modbus *. Positive data signal	1	1	4
RS485 B+	RS485 Modbus *. Negative data signal	4	4	4
CVI2	Supply output (optionally input) +12-28VDC Hardwired internally to CVI1.	2	2	0
GND	Ground to be used with CVI2. This ground is hardwired internally to the main power ground P-.	3	3	0
IGND	Ground intended to be used together with the other signals in this connector.	5	Screen wire	4

\* The RS485 pins in "COM" and "SLV" is not for general use but only for master/slave configuration.

## 4.10 Expansion module MAC00-P4/P5

Only MAC400-3000

### 4.10.12 Cables for the MAC00-P4

The following cables equipped with connectors can be supplied by JVL.

MAC00-P4 Connectors				Description	JVL Order no.	Picture
"SLV" 5pin male	"CNT" 12pin Female	"COM" 5pin Female	"PWR" 5pin Male			
		X		<b>RS232</b> Interface cable. Connects directly from MAC00-P4 to a PC Length: 5m (197 inch)	<b>RS232-M12-1-5-5</b>	
		X		<b>RS485</b> Interface cable. Connects directly from MAC00-P4 to a PC with a RS485 Com. port. Length: 5m (197 inch)	<b>RS485-M12-1-5-5</b>	
X			X	Cable (Ø5.5mm) with M12 <b>female</b> 5-pin connector loose wire ends 0.35mm <sup>2</sup> (22AWG) and foil screen. Length: 5m (197 inch)	<b>WI1000-M12F5T05N</b>	
X			X	Same as above but 20m (787 inch)	<b>WI1000-M12F5T20N</b>	
	X			Cable with M12 <b>male</b> 12 pin straight connector, loose wire ends.	<b>WI1009-M12M12T05N</b>	
	X			Same as above but 20m (787 inch)	<b>WI1009-M12M12T20N</b>	
X				RS485 Interface cable. Connects directly from a master to a slave motor via the SLV connector. Length: 3m (197 inch)	<b>WI1005-M12F5TF5T03P</b>	
<b>Protection caps. Optional if connector is not used to protect from dust / liquids.</b>						
	X	X		IP67 protection cap for M12 <b>female</b> connector.	<b>WI1000-M12FCAP1</b>	
X			X	IP67 protection cap for M12 <b>male</b> connector.	<b>WI1000-M12MCAP1</b>	

**Important:** Please note that the cables are a standard type. They are not recommended for use in cable chains or where the cable is repeatedly bent. If this is required, use a special robot cable (2D or 3D cable).



## 4.10 Expansion module MAC00-P4/P5

Only MAC400-3000

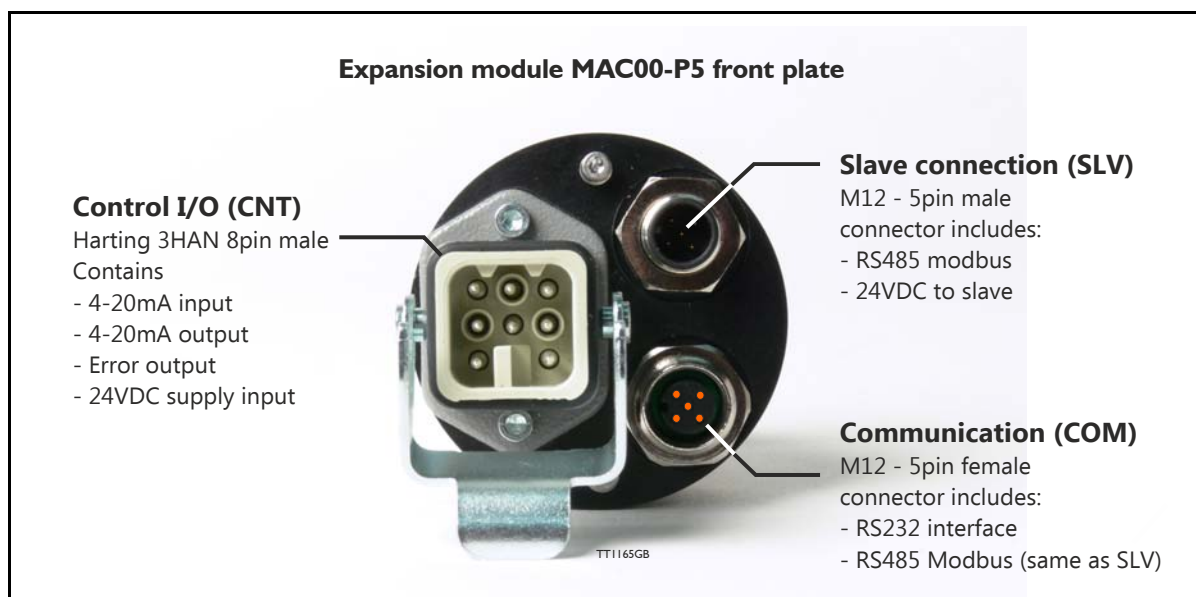

### 4.10.13 Expansion MAC00-P5 connector description

The MAC00-P5 offers IP67 only IP65 on MAC400-800 protection and M12 connectors which makes it ideal for process control and automation applications where no additional protection is desired. The M12 and Harting connectors offer solid mechanical protection and are easy to unplug compared to modules with cable glands or DSUB connectors.

The connector layout:

"CNT" - Control I/O. Harting 3HAN - 8pin male connector				
Signal name	Description	Pin no.	JVL Cable W110xxxxx	Isolation group
AIN+	4-20mA input. Positive terminal	1	Blue	2
AIN-	4-20mA input. Negative terminal	2	Red	2
AOUT+	4-20mA output. Positive terminal. Apply 7 to 24V to this terminal if internal AOUT supply is disabled.	3	Grey	3
AOUT-	4-20mA output. Negative terminal.	4	Yellow	3
O+	Supply term. to the error output. Apply 24VDC	5	Green	1
OUT1	Error output. PNP output.	6	Brown	1
P+ (CVI1)	Control supply input +12-28VDC. Consumption typical 350mA @ 24VDC and 700mA @ 24VDC if a slave motor is connected. At MAC00-P5 the CVI1 is not present but CVI1 is internally hardwired to P+.	7	White	0
P-	Main ground to be used with CVI1 and CVI2	8	Black (y)	0

\* Note: Isolation group indicate which terminals/circuits that a galvanic connected to each other. In other words group 1, 2, 3 and 4 are all fully independantly isolated from each other. Group 0 correspond to the housing of the motor which may also be connected to earth via the 115/230VAC power inlet.

(Continued next page)

## 4.10 Expansion module MAC00-P4/P5

Only MAC400-3000

<b>“COM” - Communication connector - M12 - 5pin female connector.</b>				
<b>Signal name</b>	<b>Description</b>	<b>Pin no.</b>	<b>JVL Cable “RS232- M12-1-5-5”</b>	<b>Isolation group (See note)</b>
RS232: TX	RS232 interface. Transmit terminal Leave open if unused.	1	Brown	4
RS232: RX	RS232 interface. Receive terminal Leave open if unused.	2	White	4
IGND	Ground intended to be used together with the other signals in this connector,	3	Blue	4
RS485: A-	RS485 Modbus *. Leave open if unused	4	Black	4
RS485: B+	RS485 Modbus *. Leave open if unused	5	Grey	4
<b>“SLV” - Slave connector - M12 - 5pin male connector</b>				
<b>Signal name</b>	<b>Description</b>	<b>Pin no.</b>	<b>JVL Cable “WI1005- M12F5TF5T 03P”</b>	<b>Isolation group (see note)</b>
RS485 A-	RS485 Modbus *. Positive terminal	1	1	4
RS485 B+	RS485 Modbus *. Negative terminal	4	4	4
CVI2	Supply output (optionally input) +12-28VDC Hardwired internally to CVI1.	2	2	0
GND	Ground to be used with CVI2. This ground is hardwired internally to the main power ground P-.	3	3	0
IGND	Multifunction I/O2 terminal B2+	5	Screen wire	4

\* The RS485 pins in “COM” and “SLV” is not for general use but only for master/slave configuration.

## 4.10 Expansion module MAC00-P4/P5

Only MAC400-3000

### 4.10.14 Cables for the MAC00-P5

The following cables equipped with connectors can be supplied by JVL.

MAC00-P5 Connectors			Description	JVL Order no.	Picture
"CNT" Harting 8pin male	"COM" M12 con. 5pin Female	"SLV" M12con. 5pin Male			
	X		RS232 Interface cable. Connects directly from MAC00-P5 to a PC Length: 5m (197 inch)	RS232-M12-1-5-5	
		X	RS485 Interface cable. Connects directly from a master to a slave motor. Length: 3m (197 inch)	WI1005-M12F5TF5T03P	
		X	Cable with M12 female 5 pin straight connector, loose ends. Length: 5m (197 inch)	WI1000-M12F5T05N	
		X	Same as above but 20m (787 inch)	WI1000-M12F5T20N	
X			Please contact JVL for further details	-	
<b>Protection caps. Optional if connector is not used to protect from dust / liquids.</b>					
	X		IP67 protection cap for M12 female connector.	WI1000-M12FCAP1	
		X	IP67 protection cap for M12 male connector.	WI1000-M12MCAP1	

**Important:** Please note that the cables are a standard type. They are not recommended for use in cable chains or where the cable is repeatedly bent. If this is required, use a special robot cable (2D or 3D cable).

## 4.11 Expansion Module MAC00-R1/R3/R4

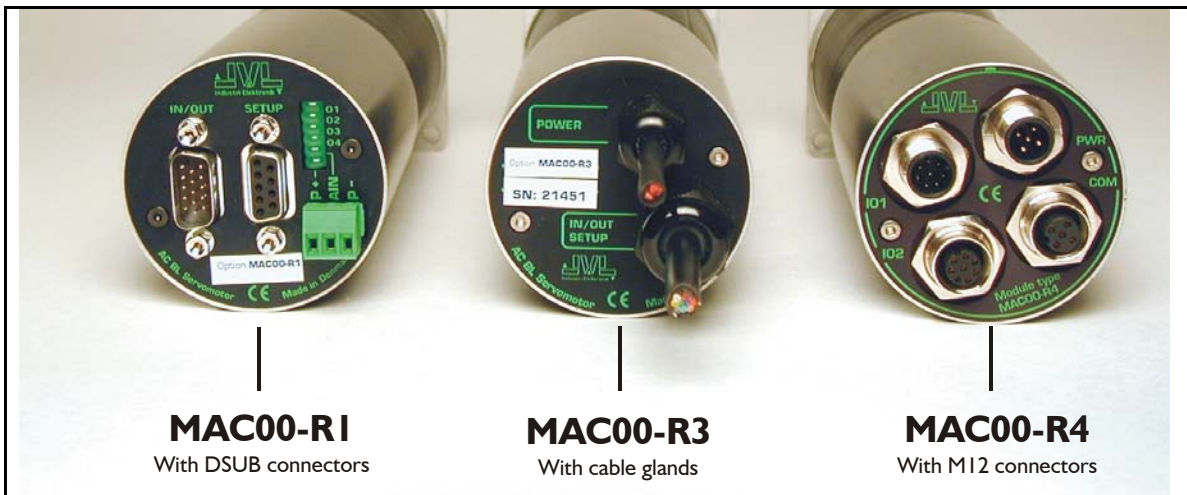

### 4.11.1 Expansion modules MAC00-R1, R3 and R4 overall description

The expansion modules MAC00-R1, R3 and R4 can be mounted on standard MAC motors MAC50, MAC95, MAC140, MAC141, MAC400, MAC402, MAC800, MAC1500 and MAC3000.

These option modules are also called “nanoPLC” modules as they perform like a small programmable logic controller with a small number of digital I/Os.

The module makes it possible to perform simple positioning, speed and/or torque control via 8 digital inputs which all are galvanically isolated and can be operated with 24V control signals from for example a PLC or external sensors.

Typical applications for these expansion modules are in stand-alone systems where the MAC motor must be able to operate as a complete positioning system without the need for an external PLC or computer. Please note that it is also possible to change or read parameters such as position, speed etc. during operation using the serial interface.

Applications typically include:

- Replacement for pneumatic cylinders.
- Dispenser systems
- Turntables
- Simple pick and place systems
- Machine adjustment/setup.

All of the modules offer the same functions but with the following hardware differences:

Type	Protection class	Connectors		
		I/O and interface	Power supply	LEDs at I/O
MAC00-R1	IP42	DSUB 9 pole	3 pole Phoenix	Yes
MAC00-R3	IP67/IP65*	Cable glands	Cable glands	No
MAC00-R4	IP67/IP65*	M12	M12	No

Note\*: IP65 on MAC400-800

The MAC00-R3 module can also be delivered with cable in selected lengths. Cables with M12 connectors can also be supplied for the MAC00-R4 module.

The first part of this section deals with the common features of both modules. Please see the latter pages of the section for see specific information about each module (for example, connection diagrams).

## 4.11 Expansion Module MAC00-R1/R3/R4

### 4.11.2 Important before use

Please note that two different types of firmware setup are available.

- **Graphic programming setup** (Firmware MAC00-RxP).
- **Fixed formats** (MAC00-Rx). See User Manual LB0047-18GB

Until Q3 2004, the only firmware available was the “fixed format type”. Since this date the fixed format firmware has not been updated and the Graphic Programming Setup is the preferred type, i.e. all new modules by default contain this new type of firmware.

The graphic programming firmware offers 100% flexibility since almost any function in the motor can be controlled using simple, user-friendly commands that are built together as a sequential program.

The user interface of both types of firmware setup is shown below.

Note: If MacTalk is used off line (no motor connected), all tabs can be seen by selecting *Show hidden pages* in the View menu.

**Graphic programming.**  
The module setup with graphic programming firmware (MAC00-RxP).  
Simple user-friendly commands can be built together forming a program with the desired function for the application.  
The function of each input and output can be user defined

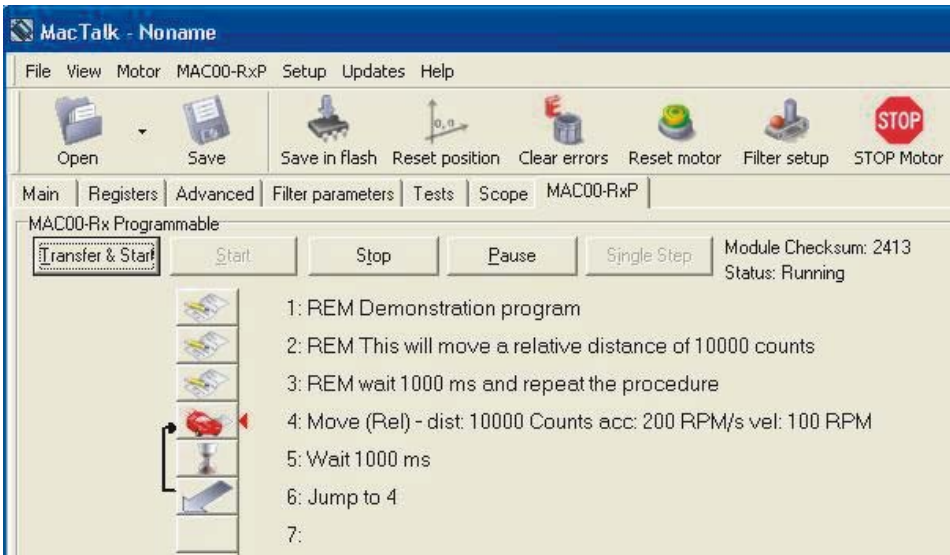

The screenshot shows the MacTalk software interface. The title bar reads "MacTalk - Noname". The menu bar includes "File", "View", "Motor", "MAC00-RxP", "Setup", "Updates", and "Help". The toolbar contains icons for "Open", "Save", "Save in flash", "Reset position", "Clear errors", "Reset motor", "Filter setup", and "STOP Motor". The "MAC00-RxP" menu is open, showing options: "Main", "Registers", "Advanced", "Filter parameters", "Tests", "Scope", and "MAC00-RxP". Under "MAC00-Rx Programmable", there are buttons for "Transfer & Start", "Start", "Stop", "Pause", and "Single Step". The "Module Checksum: 2413" and "Status: Running" are displayed. A list of program steps is shown:

- 1: REM Demonstration program
- 2: REM This will move a relative distance of 10000 counts
- 3: REM wait 1000 ms and repeat the procedure
- 4: Move (Rel) - dist: 10000 Counts acc: 200 RPM/s vel: 100 RPM
- 5: Wait 1000 ms
- 6: Jump to 4
- 7:

TT1078GB

### 4.11.3 How to set up the desired firmware

Use the following step-by-step instruction to set up the desired firmware.  
(continued next page).

# 4.11 Expansion Module MAC00-R1/R3/R4

## Step 1

Determine which firmware you want to use:  
Graphic programming (MAC00-RxP).

## Step 2

Choose the *Firmware update* in the *Updates* menu.

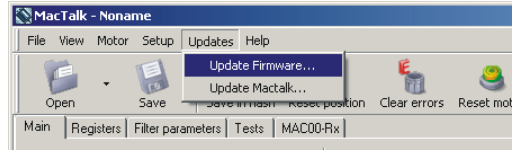

## Step 3

Make sure that the checkbox "Show all files" is checked.

Select the desired firmware, MAC00-RxP.  
Note that there may exist more than one version. Choose the newest version.

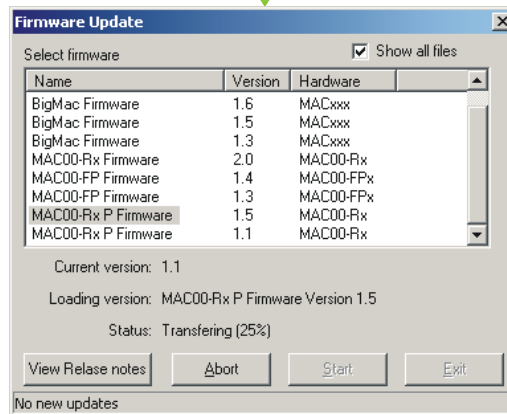

Press *Start* to download the selected firmware.  
The progress counter will now rise from 0 to 100%.

## Step 4

When the download process is finished, the status shows "Done".

Also "Current version" has changed to the actual downloaded version meaning that the firmware in the module is now changed permanently.

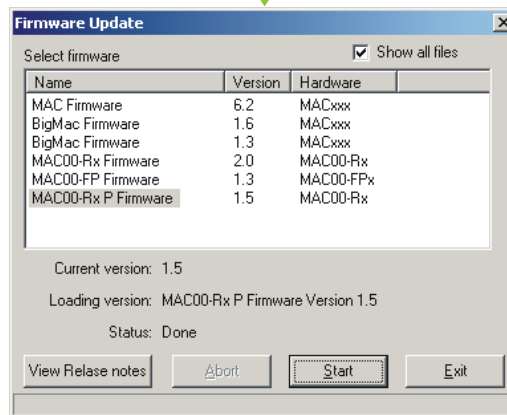

## Step 5

The on-line information shown in the lower right corner of the MacTalk main window will now show the complete type of firmware and version.

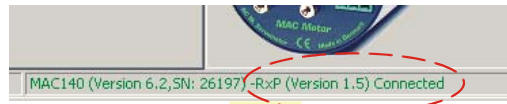

## Step 6

The *MAC00-RxP* tab is now available among the other standard tabs.

Proceed with the setup and/or programming according to the description for each firmware type.

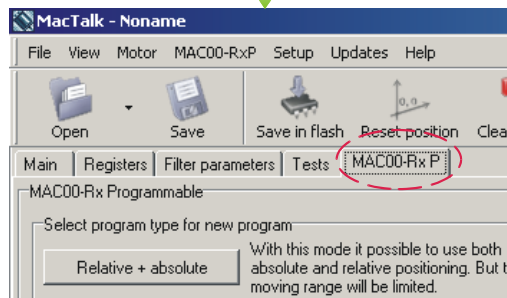

TT1079GB

## 4.11 Expansion Module MAC00-R1/R3/R4

### 4.11.4 Getting started with MAC00-RxP

When using the MAC00-R1, R3 or R4 module with MAC00-RxP firmware, almost any kind of program can be created using a set of user-friendly icons.

To create a program, first of all it must be determined whether the application requires that the motor always stays within the allowed position range which is  $\pm 67.108.863$  counts or if the application requires that the motor mostly moves in only one direction, meaning that sooner or later it will pass the maximum limit of counts mentioned above.

Typical applications for the two program types are:

<b>Relative + Absolute</b>	XY tables Pick and place robots Valve actuators
<b>Endless relative</b>	Dispensers for film, labels etc. Dosing pumps Turntables Torque-controlled screw machines

Make the choice on the MAC00-RxP tab.

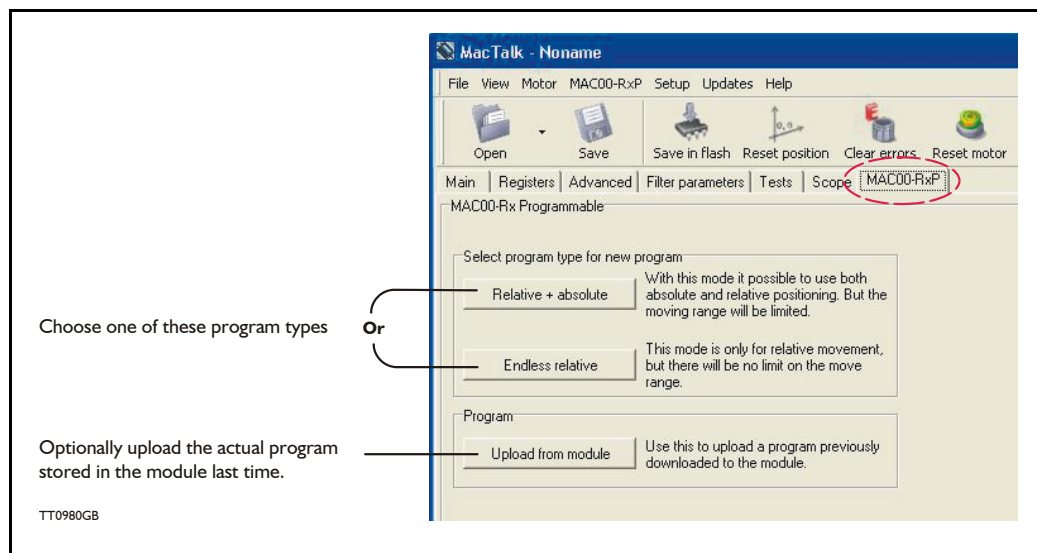

After making one of these 3 choices above, the program window will be opened.



# 4.11 Expansion Module MAC00-R1/R3/R4

## 4.11.5 MAC00-RxP Main window

The main window for creating a new program or editing a program is shown below:

**MAC00-RxP menu**  
Main menu for creating a new program, Verifying program size and other basic details for the MAC00-RxP module.

**Transfer & Start**  
Will transfer the complete program and start it. Use *Stop* or *Pause* to stop it.

**Stop**  
Use this button if the program must be stopped.

**Program lines**  
Each button represents a program line. By pushing the button a command can be entered at the program line.

**MAC00-RxP Status texts**  
The message *Program not transferred* means that there is a difference between the program seen on the screen and the actual program in the module. This can happen if the program have been edited but not transferred. *Status: Running* (or *Stopped*) refers to the program in the module.

**Pause**  
Use this button if the program must be paused. Paused means that the actual program line executed is temporarily paused. When paused, the single step feature can be used to debug the program.

**MAC00-RxP**

- New program
- Program setup
- Upload program
- Program information

TT0981GB



# 4.11 Expansion Module MAC00-R1/R3/R4

## 4.11.6 MAC00-RxP menu

The MAC00-RxP menu found at the top of the main window gives access to following possibilities:

**MAC00-RxP menu:**

- MAC00-RxP
- New program — Described elsewhere in this chapter
- Program setup — Upload the program from the module to MacTalk
- Upload program — Upload the program from the module to MacTalk
- Program information

**Program + Source**  
Shows the memory usage if the program (compiled)+source program and remarks is downloaded into the module.

**Program + Source - REM**  
Same as above but without remarks.

**Program only**  
Same as above but without source program and remarks.

**Checksum**  
Shows the checksum of the complete program downloaded into the module. The checksum is unique and can be used to verify whether the program in the module matches the original program or not.

**Lines**  
The number of program lines used in the source program (MacTalk)

**Mode**  
Specify the program type actually used.

**Enable input filter**  
Enables an oversampling filter at the inputs IN1 to IN8. This feature can be used to remove noise from the inputs.

**Skip initialization (advanced)**  
Bypasses internal initialization routines after powerup. (Only for very special use).

**Program + Source + Remarks**  
Default. Choosing this will transfer everything into the module memory. This can be an advantage if remarks and source program must be uploaded to MacTalk later.

**Program + Source**  
Same as above but without remarks.

**Program only**  
Only the compiled program is transferred.

**Program information dialog:**

Sizes:	
Program + Source:	80 B
Program + Source - REM:	80 B
Program only:	53 B

General Information:  
Checksum: 2957  
Lines: 5  
Program type: Absolute and relative

**Setup dialog:**

Settings:  
 Enable input filter  
 Skip initialization (advanced)

Transfer settings:  
 Program + Source + Remarks  
 Program + Source  
 Program only

TT0982GB

# 4.11 Expansion Module MAC00-R1/R3/R4

## 4.11.7 How to build a program

When choosing New program in the MAC00-RxP menu or entering MacTalk for the first time, programming can be started.  
Press the button at line 1 and a tool box will pop up.

**1** Press the first button to create the first program line. The "Select command" box will pop up.

**2** Choose the desired command. In this example it is desired to wait for an input to be activated before further program execution.

**3** Choose to wait until input 5 is high and press OK

**4** The command is inserted at the previous selected program line

TT0983GB

Continued

# 4.11 Expansion Module MAC00-R1/R3/R4

**5** Press the second button to create the second program line

**6** Choose the movement type needed. Relative: Move x counts forward with reference to the actual position. Absolute: Move to the x position with reference to the zero search position.

**7** The relative move command just entered is converted into a program line.

**8** Multiple program lines are entered by the user forming the last part of the program.

**9** Now the program is finished. Press the "Transfer & Start" button. Now the program will be transferred and stored permanently in the module. The program will be executed immediately.

TT0984GB

Continued

## 4.11 Expansion Module MAC00-R1/R3/R4

**10** Now the program is running continuously. The actual program line which is executed is shown by the small red arrow.

**11** By choosing the "Pause" button, the program is paused. After it is paused, it is possible to single step through each program line which can be a useful feature to debug the program since the action in each line can be closely observed.

**12** When the program is finished, it can be saved on the harddisc or floppy disc. Please be aware that when saving the program it is the complete program including the overall setup of the motor such as servofilter, I/O setup etc. Everything is stored in a file with the extension .MAC. Later it can be opened and restored in the motor.

TT0985GB

### 4.11.8 General programming hints

When a program is built and saved, the following hints may be useful to ensure that the program behaves as expected.

1. When transferring the program to the module it is saved permanently in the memory and the program will be executed each time the motor is switched on.
2. Before making a program, ensure that the basic parameters for controlling acceleration, torque, safety limits, etc. are set to proper values. When saving the program on the hard disk or floppy disk, all of these basic parameters will be saved together with the program as a complete motor setup package.
3. A program line can be edited by double-clicking the command text.
4. When the cursor is placed on top of the command icon, an edit menu can be called up with a right-click.

# 4.11 Expansion Module MAC00-R1/R3/R4

## 4.11.9 Command toolbox description

The toolbox used for programming comprises 16 different command types. The idea is for the commands to give easy access to the most common functions in the motor. Some functions may seem to be missing at first sight but the buttons “Set register in the MAC motor” or “Wait for a register value before continuing” give direct access to +50 registers down in the basic MAC motor, such as the gear ratio or the actual torque register.

In total this provides a very powerful programming tool since >95% of a typical program can be built using the simple command icons and the remaining part is obtained by accessing the basic motor registers directly.

A short description of all 16 command icons is given below.

Use: Initiates any motor movement relative or absolute.

Use: Unconditional jump from one program line to another.

Use: Inserts a delay in the program specified in milliseconds.

Use: Write a value to almost any register in the basic MAC/MIS motor.

Use: Wait for a certain state at one or more of the digital inputs.

Use: Initiates a zero search to a sensor or a torque (no sensor).

Use: Change mode and activate register using a single command.

Use: Inserts a remark/ Comment in the program source code.

Use: Set the motor in the desired mode such as position- or velocity mode.

Use: Set a certain state at one or multiple digital outputs.

Use: Conditional jump from one program line to another. Input dependent

Use: Wait for a certain state at one or multiple digital inputs.

Use: Conditional jump from one program line to another. Register dependent

Use: Save the actual motor position to an intermediate register.

Use: Preset the position counter to a certain value.

Use: Binary format instead of graphic commands.

Use: Performs a calculation using register values and constants.

Use: Compares two registers to each other before jumping or moving in the program.

TT1103-02GB

## 4.11 Expansion Module MAC00-R1/R3/R4

### 4.11.10 RxP Command Reference

#### 4.11.11 Enter your own remarks

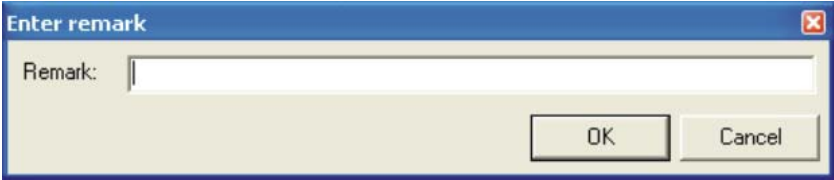
Icon:	
Dialogue:	
Function:	Inserts a remark/comment in the source code. The program line will not do anything, but can make the source code easier to read. This can be very important, if other programmers have to review or work on the code, or if the program is only worked on infrequently.

#### 4.11.12 Set operation mode

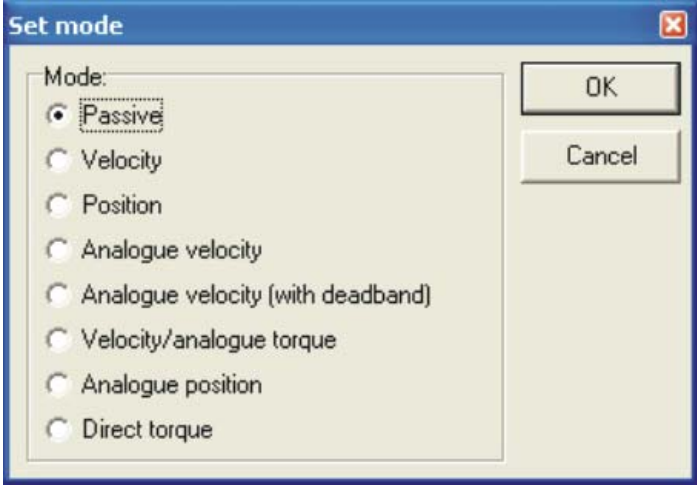
Icon:	
Dialogue:	
Function:	Sets the operating mode for the motor. When the program encounters a program line with this command, the motors operating mode will be set to the specified mode. This allow you to use different operating modes in different parts of the program. For a detailed description of the individual operating modes, refer to section 1.2.1

## 4.11 Expansion Module MAC00-R1/R3/R4

### 4.11.13 Move operations

Icon:	
Function:	The Move command is very flexible, with five different operating modes. Each mode will be described in its own section

### 4.11.14 Move Relative

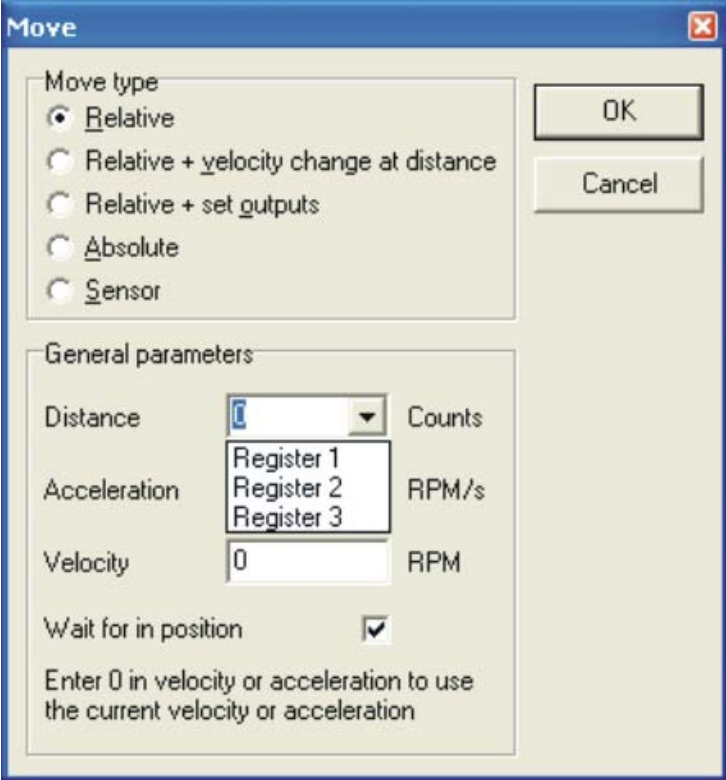
Icon:	
Dialogue:	
Function:	Performs a movement relative to the current position. The distance moved is measured in encoder counts, and can either be entered directly, or taken from three memory registers in the RxP module. For further information on using these memory registers, refer to the sections on the "Save position" and "Set position" commands. Note that if you specify a velocity, motor register no. 5 (V_SOLL) will be over written with this velocity value. Also, if you specify an acceleration, motor register no. 6 (A_SOLL) will be overridden with the acceleration value you specified. Register no. 49 (P1) is always over written by this command. If the "Wait for in position" option is checked, the program will wait until the motor has finished the movement, before proceeding to the next program line. If this option is not checked, the program will start the movement, then immediately start executing the next command. The motor will finish the movement on its own, unless it is given other instructions by the program.



# 4.11 Expansion Module MAC00-R1/R3/R4

## 4.11.15 Move (Relative + velocity change at a distance)

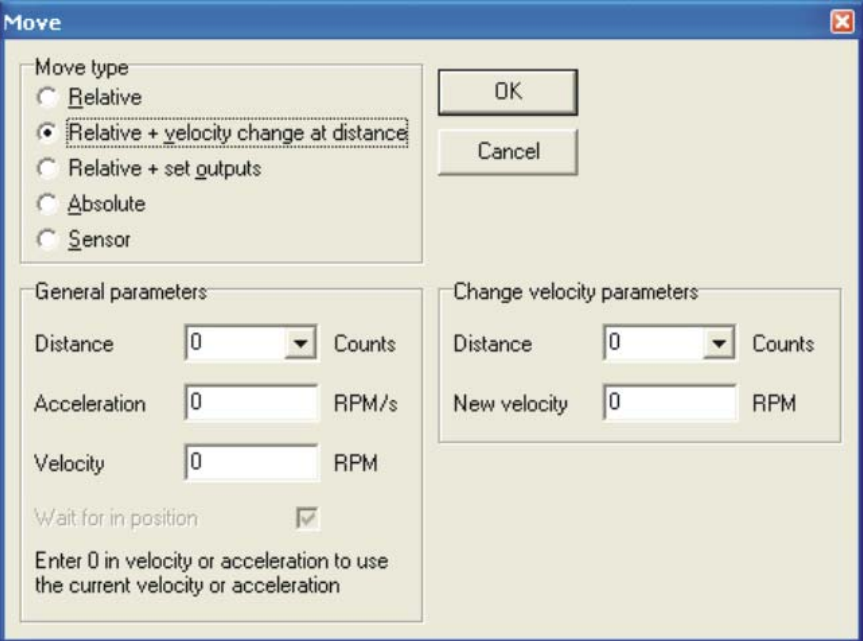
Icon:	
Dialogue:	
Function:	<p>Performs a relative movement, and changes velocity a specified distance before reaching the new position. The distance are measured in encoder counts, and can either be entered directly, or taken from three memory registers in the RxP module. For further information on using these memory registers, refer to the sections on the “Save position” and “Set position” commands.</p> <p>Note that motor register no. 5 (V_SOLL) will be over written with the value specified in the “New velocity” field. Also, if you specify an acceleration, motor register no. 6 (A_SOLL) will be over written with the acceleration value you specified. Register no. 49 (P1) is always overridden by this command. This command always wait until the movement is finished, before proceeding to the next line in the program.</p>



## 4.11 Expansion Module MAC00-R1/R3/R4

### 4.11.16 Move (Relative + set outputs)

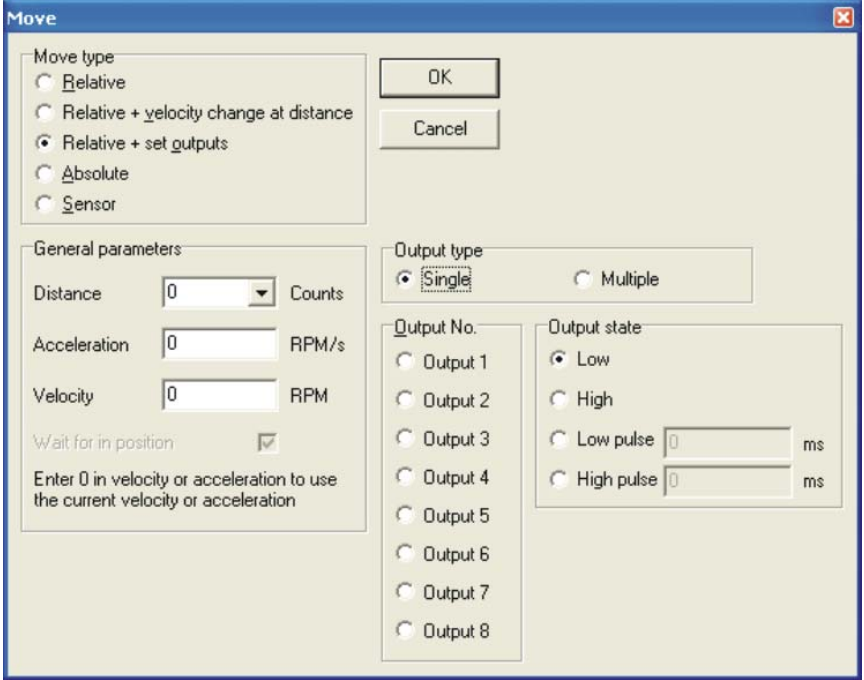
Icon:	
Dialogue:	
Function:	<p>Performs a movement relative to the current position, and sets one or more outputs on the RxP module when the operation is completed. The distance moved is given in encoder counts, and can either be entered directly, or can be taken from one of three memory register in the RxP module. For further information on using these memory registers, refer to the sections on the "Save position" and "Set position" commands. Note that if you specify a velocity, motor register no. 5 (V_SOLL) will be over written with this velocity value. Also, if you specify an acceleration, motor register no. 6 (A_SOLL) will be over written with the acceleration value you specified. Register no. 49 (P1) is always over written by this command. This command always wait until the movement is finished, before proceeding to the next line in the program.</p>

## 4.11 Expansion Module MAC00-R1/R3/R4

### 4.11.17 Move (Absolute)

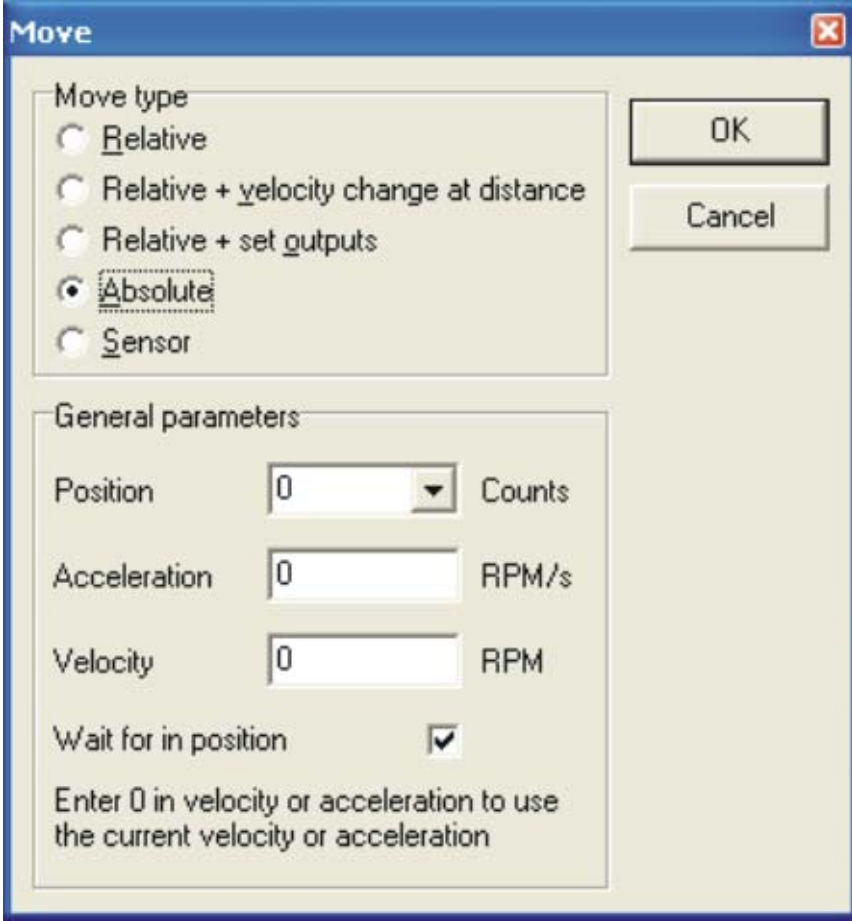
Icon:	
Dialogue:	
Function:	<p>Moves to an absolute, non-relative position. The position is given in encoder counts, and can either be entered directly, or can be taken from one three memory register in the RxP module. For further information on using these memory registers, refer to the sections on the "Save position" and "Set position" commands.</p> <p>Note that if you specify a velocity, motor register no. 5 (V_SOLL) will be overwritten with this velocity value. Also, if you specify an acceleration, motor register no. 6 (A_SOLL) will be over written with the acceleration value you specified. If the "Wait for in position" option is checked, the program will wait until the motor has finished the movement, before proceeding to the next program line. If this option is not checked, the program will start the movement, then immediately start executing the next command. The motor will finish the movement on its own, unless it is given other instructions by the program.</p>

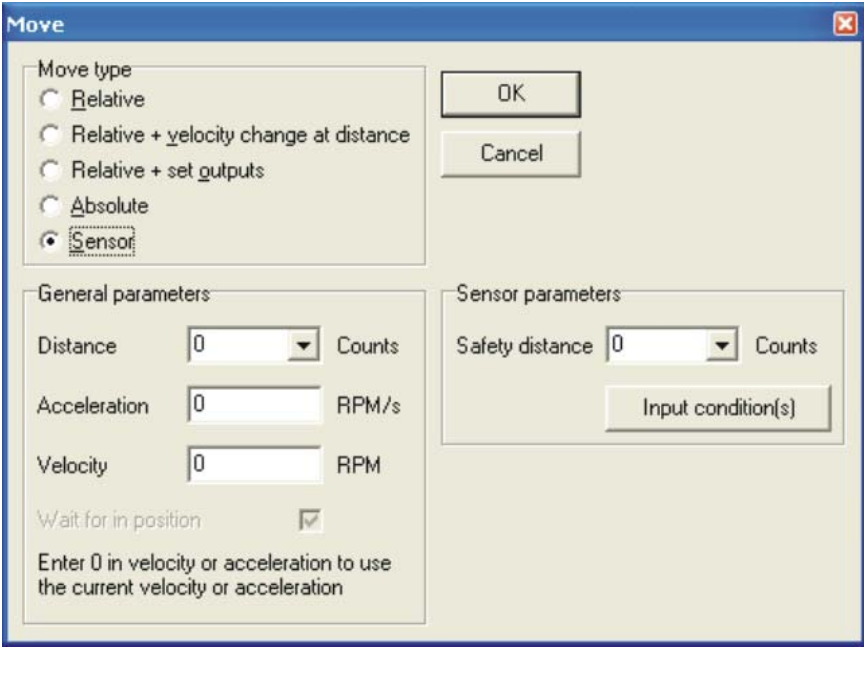

## 4.11 Expansion Module MAC00-R1/R3/R4

### 4.11.18 Move (Sensor)

Icon:	
Dialogue:	
Function:	<p>Performs a movement in the direction specified, until an input condition is satisfied. The motor then moves the distance specified, before stopping. The motor will not move farther than the Safety distance specified, regardless of whether the input condition is satisfied. The distances are measured in encoder counts, and can either be entered directly, or can be taken from one of three memory register in the RxP module. For further information on using these memory registers, refer to the sections on the "Save position" and "Set position" commands. Note that if you specify a velocity, motor register no. 5 (V_SOLL) will be over written with this velocity value. Also, if you specify an acceleration, motor register no. 6 (A_SOLL) will be over written with the acceleration value you specified. Register no. 49 (P1) is always overridden by this command This command always wait until the movement is finished, before proceeding to the next line in the program.</p>

# 4.11 Expansion Module MAC00-R1/R3/R4

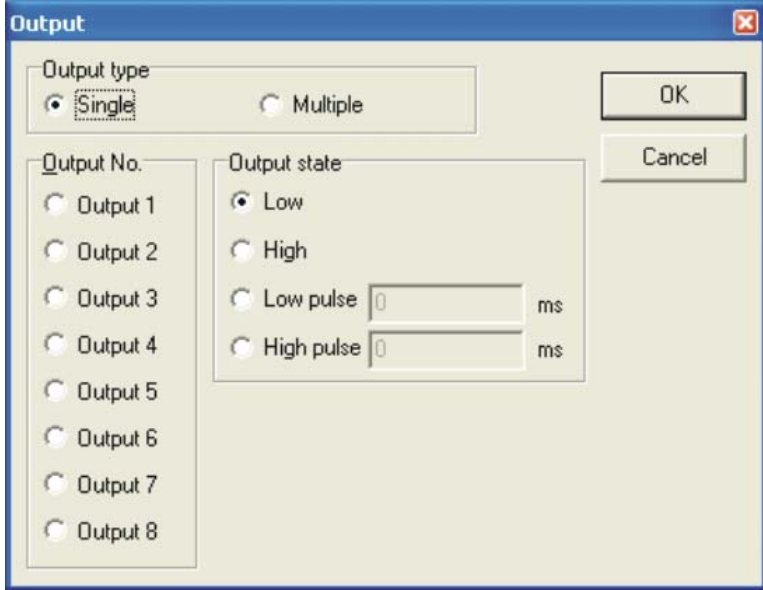
## 4.11.19 Set outputs

Icon:	
Dialogue:	 
Function:	<p>Sets one or more outputs on the RxP module. When setting a single output, you can specify the length (in milliseconds) of a pulse to send out on that output. When setting multiple outputs, you can specify whether to set each output high, low, or leave it in its current state</p>

## 4.11 Expansion Module MAC00-R1/R3/R4

### 4.11.20 Unconditional jump

Icon:	
Dialogue:	None. After selecting this command, the mouse cursor changes. The next program line that you click on will become the destination for the jump.
Function:	Jumps to another line in the program

### 4.11.21 Conditional jump (single input)

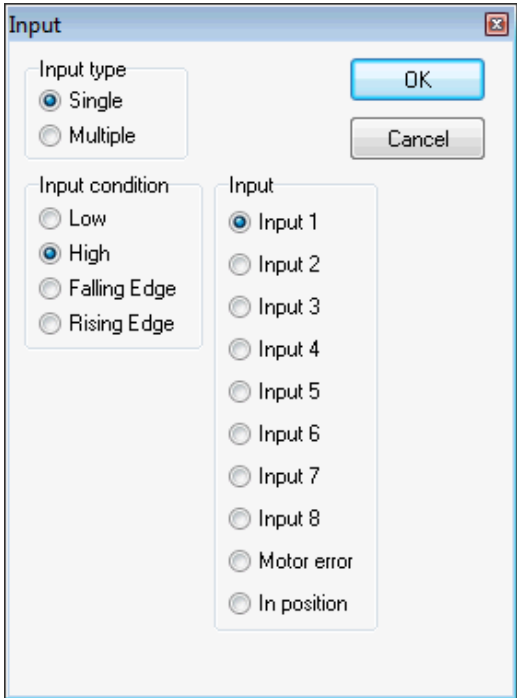
Icon:	
Dialogue:	
Function:	<p>Tests for an input condition, before either jumping to another line in the program, or moving on to the next line in the program. If the condition is met, the command jumps to the specified program line. If the condition is not met, the program proceeds to execute the next line in the program.</p> <p>When "input type" is set to "single", the command can test a single input for one of four possible conditions: the input is low, the input is high, the input has transitioned to low (Falling Edge), or the input has transitioned to high (Rising Edge). If transitions are tested for, the transition must have taken place during the last 30 microseconds.</p> <p>After pressing the OK button, the dialogue will disappear, and the mouse cursor will change. The next program line that you click on will then become the destination for the jump command</p>

## 4.11 Expansion Module MAC00-R1/R3/R4

### Example 1- Conditional jump controlled by level at an input

The program example below shows how a jump to line 5 is done IF input 3 is active (applied with a voltage from outside).

If input 3 is NOT active the program execution just goes on from line 2.

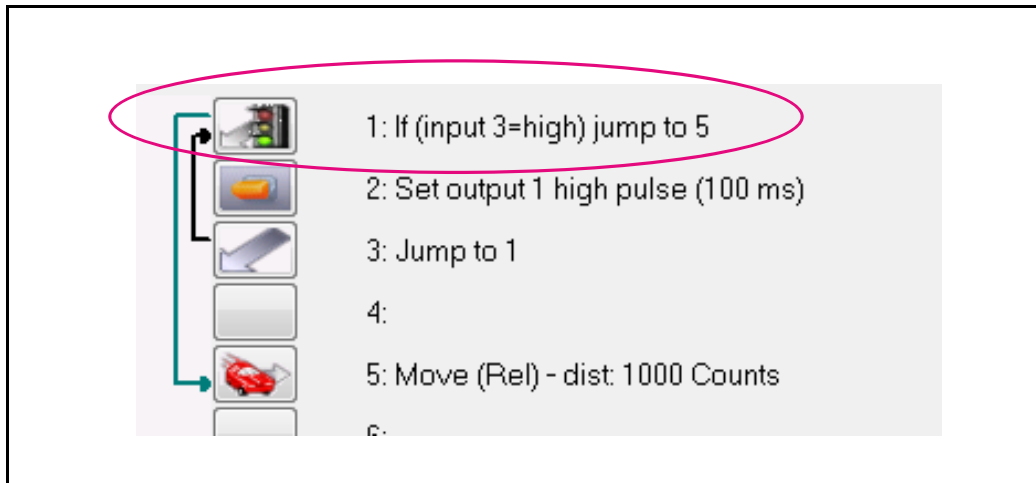

### Example 2- Conditional jump controlled by shift at an input

The program example below shows how a jump to line 5 is done IF a rising edge (shift from 0 to 1) at input 1 has happened since last jump with the same condition was executed.

If no shift was detected the program execution just goes on from line 2.

Notice that the function do not check directly at the input but uses an internal flag which is set every time a rising edge is detected.

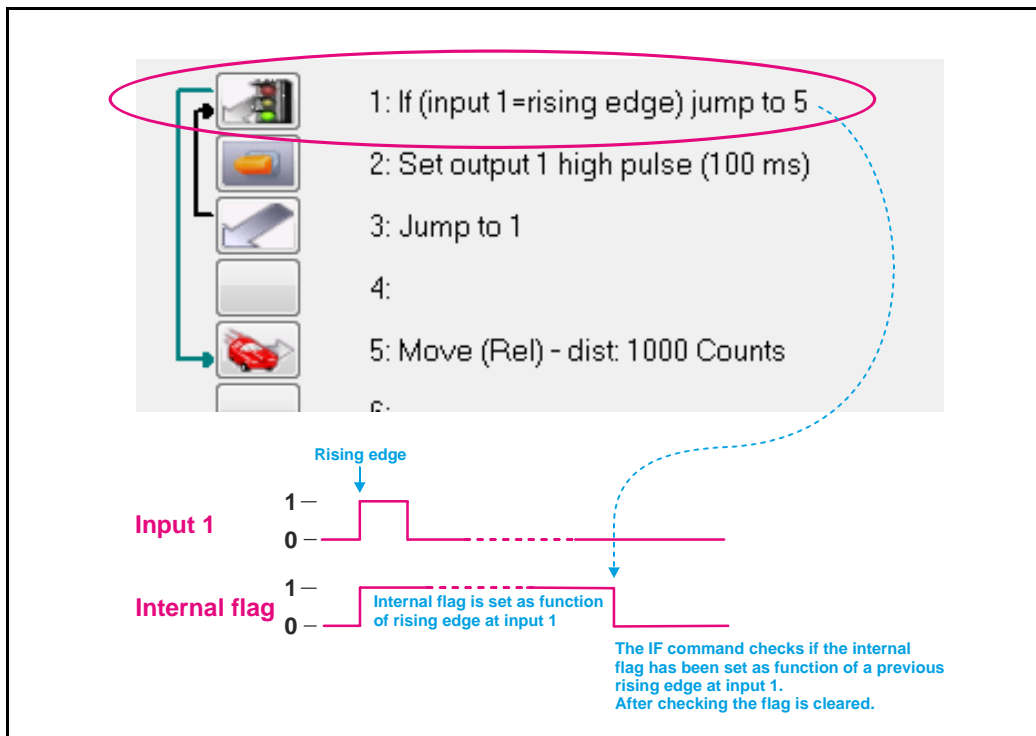

## 4.11 Expansion Module MAC00-R1/R3/R4

### 4.11.22 Conditional jump (multiple input)

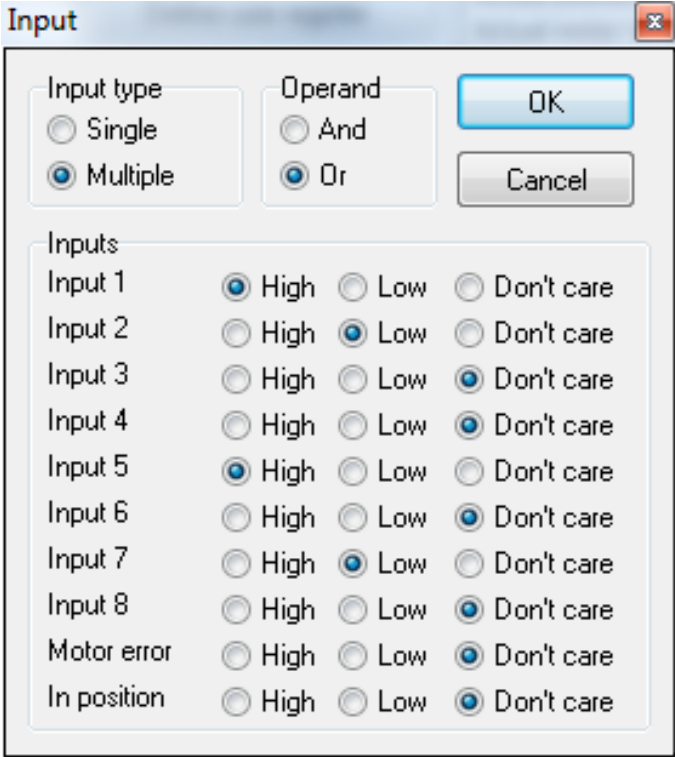
Icon:	
Dialogue:	
Function:	<p>Tests for an input condition, before either jumping to another line in the program, or moving on to the next line in the program. If the condition is met, the command jumps to the specified program line. If the condition is not met, the program proceeds to execute the next line in the program. When "input type" is set to "Multiple", Multiple inputs can be tested for being either high or low.</p> <p>The "Operand" setting determines whether one or all of the inputs must meet their test criterion. If set to "And", all inputs must match their test settings. If set to "Or", only one input need to match its test setting. Inputs that are set to "Don't care" are not tested.</p> <p>After pressing the OK button, the dialogue will disappear, and the mouse cursor will change. The next program line that you click on will then become the destination for the jump command.</p>

## 4.11 Expansion Module MAC00-R1/R3/R4

### 4.11.23 Wait for (x) ms before continuing

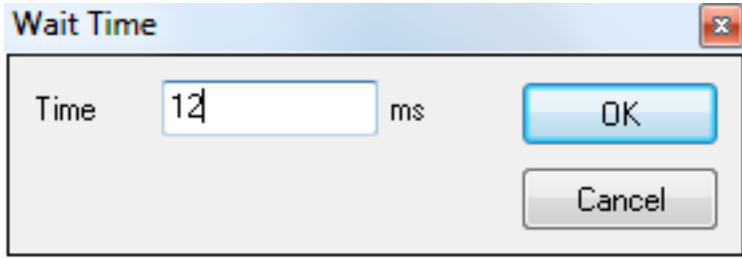
Icon:	
Dialogue:	
Function:	Causes the program to pause for a number of milliseconds, before continuing. The longest pause that can be specified is 65535 milliseconds. The shortest pause that can be specified is 0 milliseconds. Note that this command over writes Timer 1 in the RxP modules memory.



## 4.11 Expansion Module MAC00-R1/R3/R4

### 4.11.24 Wait for an input combination before continuing (single input)

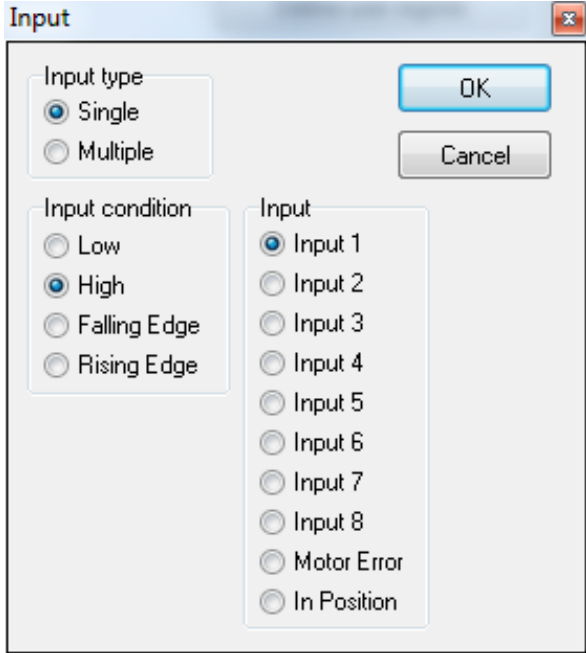
Icon:	
Dialogue:	
Function:	<p>Waits for a specified input condition to occur. The next line in the program will not be executed until the input condition has been met. If "Input type" is set to "Single", the command will wait for one of four things to happen on the specified input: that the input tests as high, that the input tests as low, that the input transitions from high to low (Falling Edge). The input is tested with 30 microsecond intervals.</p>

Examples shown at next page.

## 4.11 Expansion Module MAC00-R1/R3/R4

### Example 1- Wait for level at an input

The program example below shows how a wait command is stalling the program execution until input 3 is active (applied with a voltage from outside).  
If input 3 is NOT set active the program execution stay in line 1.

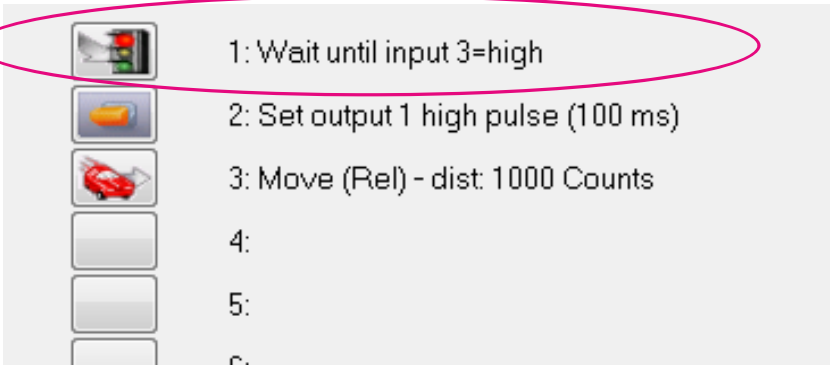

1: Wait until input 3=high  
2: Set output 1 high pulse (100 ms)  
3: Move (Rel) - dist: 1000 Counts  
4:  
5:  
6:

### Example 2- Wait for a shift at an input

The program example below shows how a wait command is stalling the program execution until input 1 is applied a rising edge (shift from 0 to 1).  
If input 1 is NOT applied a rising edge the program execution keeps waiting in line 1.

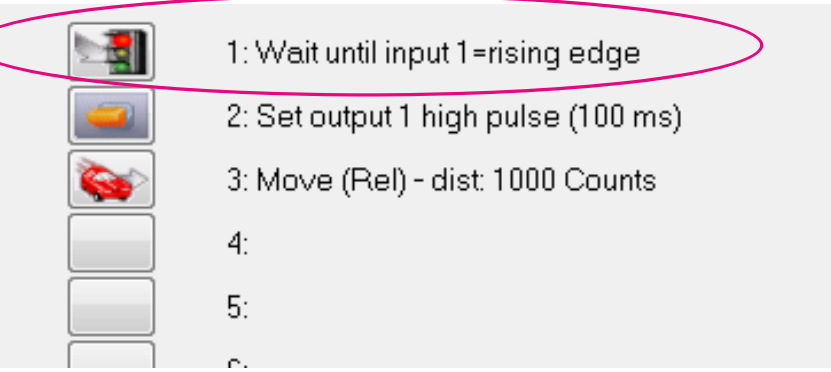

1: Wait until input 1=rising edge  
2: Set output 1 high pulse (100 ms)  
3: Move (Rel) - dist: 1000 Counts  
4:  
5:  
6:

Input 1

1 -  
0 -

Program line

1	2	3	4	5	6	7	8	9
---	---	---	---	---	---	---	---	---

The program execution stay in line 1 until a rising edge have been applied

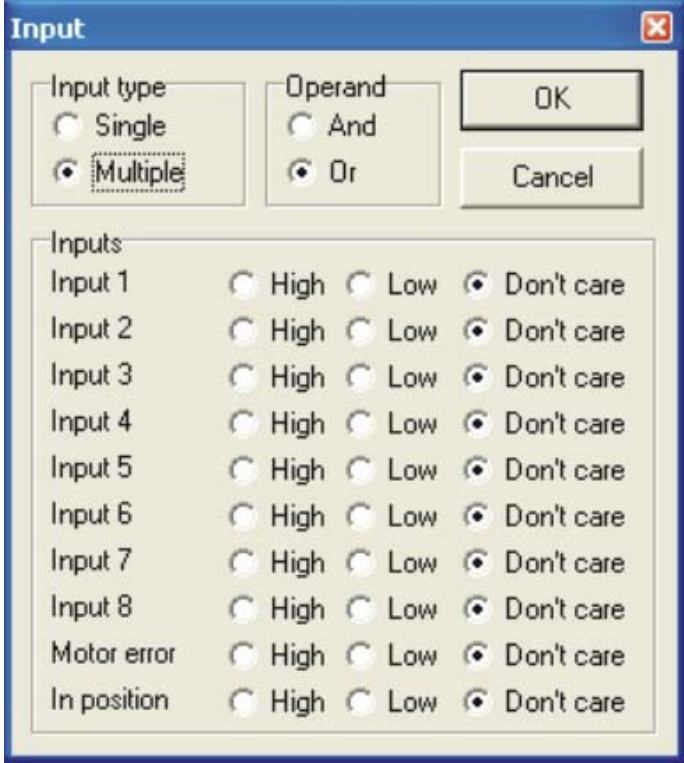

## 4.11 Expansion Module MAC00-R1/R3/R4

### 4.11.25 Wait for an input combination before continuing (multiple inputs)

Icon:	
Dialogue:	
Function:	<p>Waits for a specified input condition to occur. The next line in the program will not be executed until the input condition has been met. If "Input type" is set to "Multiple", multiple inputs can be tested for being either high or low.</p> <p>The "Operand" setting determines whether one or all of the inputs must meet their test criterion. If set to "And" all inputs must match their test settings. If set to "Or" only one input need to match its test setting. Inputs that are set to "Don't care" are not tested. The inputs are tested with 30 microsecond intervals.</p>

## 4.11 Expansion Module MAC00-R1/R3/R4

### 4.11.26 Sets a register in the MAC-motor

Icon:	
Dialogue:	
Function:	<p>Sets a register in the motor to a specified value. The register is selected from a list of known, user-accessible registers. The value can either be entered as native motor units, or it can be entered as generic engineering units. The dialogue shown provides an example: register no. 3 (P_SOLL, or requested position, depending on your preference) can either be set to an integer number of encoder counts, or it can be set to a non-integer number of revolutions.</p>

### 4.11.27 Jump according to a register in the MAC motor

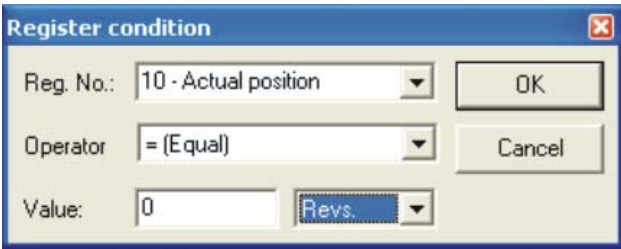

Icon:	
Dialogue:	
Function:	<p>Tests a register in the motor against a specified value, before either jumping to another line in the program, or moving on to the next line in the program.</p> <p>If the condition is met, the command jumps to the specified program line. If the condition is not met, the program proceeds to execute the next line in the program. The value can either be entered as native motor units, or it can be entered as generic engineering units.</p> <p>The dialogue shown provides an example: register no. 10 (P_IST, or Actual position, depending on your preference) must be equal to 0 revolutions, if the jump is to be made. The position that the register is tested against can be specified as an integer number of encoder counts, or it can be specified as a non-integer number of revolutions.</p> <p>After pressing the OK button, the dialogue will disappear, and the mouse cursor will change. The next program line that you click on will then become the destination for the jump command.</p>

## 4.11 Expansion Module MAC00-R1/R3/R4

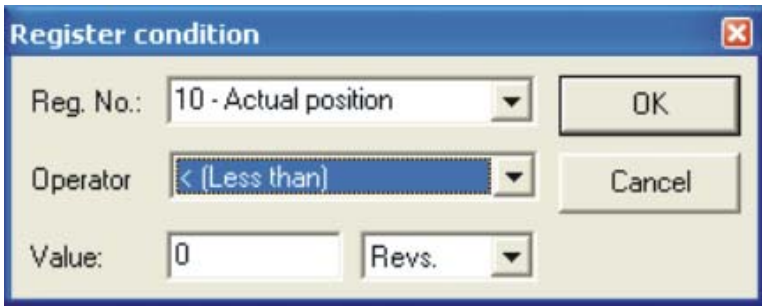
### 4.11.28 Wait for a register value before continuing

Icon:	
Dialogue:	
Function:	<p>Tests a register in the motor against a specified value, and waits until the specified condition is met. The value can either be entered as native motor units, or it can be entered as native motor units, or it can be entered as generic engineering units.</p> <p>The dialogue shown provides an example: register no. 10 (P_IST, or Actual position, depending on your preference) must be less than 0 revolutions, before the program can continue.</p> <p>The position that the register is tested against can be specified as an integer number of encoder counts, or it can be specified as a non-integer number of revolutions.</p>

### 4.11.29 Save position

Icon:	
Dialogue:	
Function:	<p>Saves the current position, from register no. 10 (P_IST), to one of three locations in memory on the RxP module. The saved position(s) can then be used wherever a position or distance is needed in a move command.</p>

## 4.11 Expansion Module MAC00-R1/R3/R4

### 4.11.30 Set position

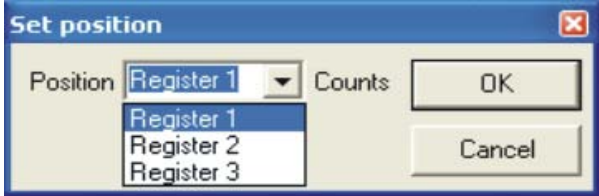
Icon:	
Dialogue:	
Function:	Sets the current position, held in register no. 10 (P_IST), to one of three position values stored in memory on the RxP module. This is the reverse of the "Save position" command.

### 4.11.31 Send FastMac command (change mode and activate register)

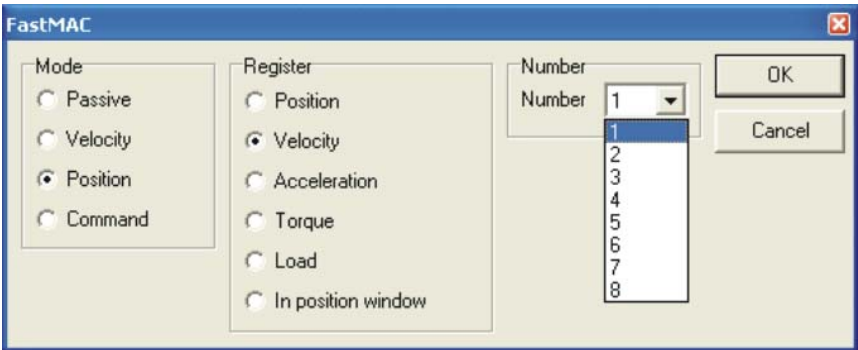

Icon:	
Dialogue:	
Function:	FastMAC commands are also sometimes referred to as FlexMAC commands. The advantage of these commands is a very low communications overhead. FastMAC/FlexMAC are described in detail in section 4.5.7. However, a brief summary is in order. If "Mode" is set to one of "Passive", "Velocity", or "Position", the motor will switch into that mode. Also, one of the passive motor registers will be activated, in the sense that its value will be written to the corresponding active motor register, which actually controls motor behaviour. In the example above, the value in register no. 65 (V1) will be written to register no. 5 (V_SOLL). Move operations will then take place at that velocity.

## 4.11 Expansion Module MAC00-R1/R3/R4

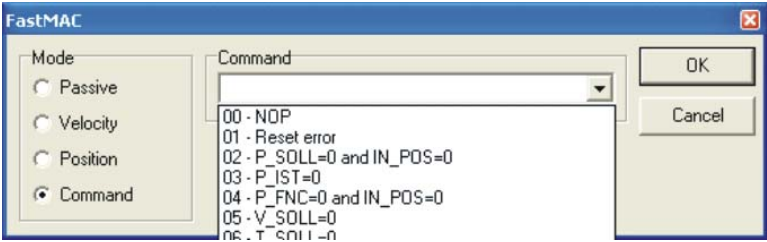
### 4.11.32 Send FastMac command (macro command)

Icon:	
Dialogue:	
Function:	<p>If "Mode" is set to "Command", the motor does not necessarily change mode, but it can be ordered to carry out a series of predetermined operations.</p> <p>Describing all the FastMAC commands is beyond the scope of this section, but as an example, you can activate four different sets of registers, each controlling position, velocity, acceleration, torque, load factor, and in position window, all with a single command.</p> <p>For further details, refer to section 4.9.7.</p>

### 4.11.33 Binary command

Icon:	
Dialogue:	
Function:	<p>MacTalk RxP module programs are sent to the motor in a compact binary format, which is then interpreted by the RxP modules firmware.</p> <p>The existing set of graphic commands covers most situations, but when special needs arise, anything that can be done with the RxP module can be done with a binary command. If you find yourself with special needs, that are not covered by the other commands, contact JVL for assistance.</p>

## 4.11 Expansion Module MAC00-R1/R3/R4

### 4.11.34 Calculator (basic)

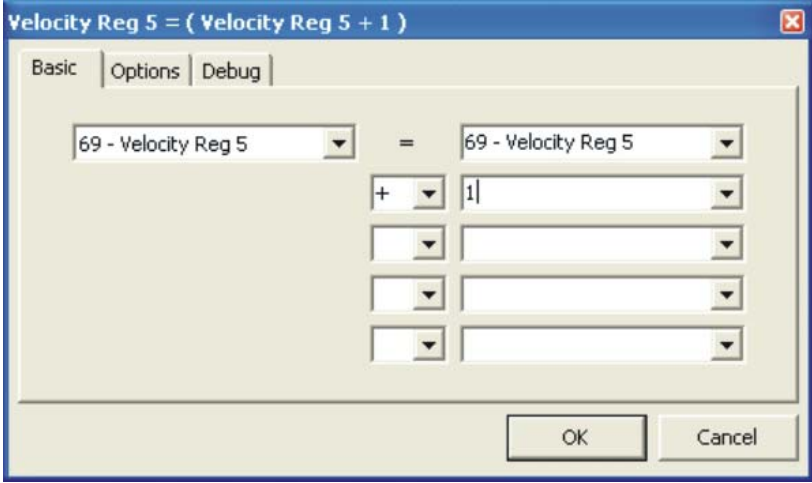
Icon:	
Dialogue:	
Function:	<p>Performs a calculation using register values, constants, and the four basic arithmetic operations: +, -, * and /. The result is stored in a register. Arithmetic operations take place in the order they are specified. Operands/arguments can be either integer constants or registers. The caption of the dialogue box shows the resulting expression in traditional in fix format. It is continuously updated as you type in the expression.</p> <p>Note that if you write a value to a register, using this command, that value is always measured in native motor units. Conversion from generic engineering units is only supported for the commands "Set a register in the MAC motor".</p> <p>"Jump according to a register in the MAC motor", and "Wait for a register value before continuing".</p>



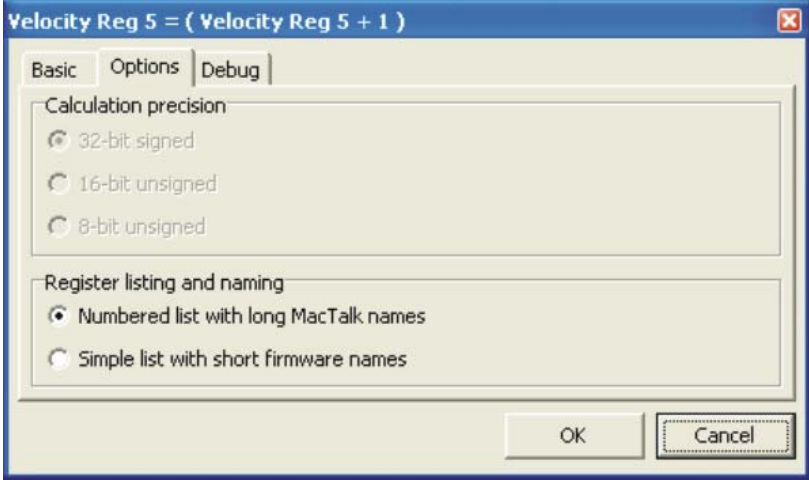

## 4.11 Expansion Module MAC00-R1/R3/R4

### 4.11.35 Calculator (Options)

Icon:	
Dialogue:	
Function:	<p>The options tab contains various settings that affect the operation of the Calculator command. “Calculation precision” is, at the time of writing, locked to 32-bit precision. This is not an error, and should not be reported. “Register listing and naming” provides an alternative method of entering ata into the dialogue, by selecting “simple list with short firmware names”. Instead of selecting, for example, “3 Requested position” to access register no. 3, you can simply type “P_SOLL”. If you wish to enter a constant, you simply enter the digits-the dialogue will not mistake the constant for a register number.</p> <p>If you are in doubt about a register name, look at the expression in the caption of the dialogue box. A recognized register name will appear in the expression. An unrecognized register name will appear as a zero. You can switch between the two methods of data entry at any time.</p>

## 4.11 Expansion Module MAC00-R1/R3/R4

### 4.11.36 Jump according to a comparison

Icon:	
Dialogue:	
Function:	<p>Compares two registers to each other, before either jumping to another line in the program, or moving on to the next line in the program. If the condition is met, the command jumps to the specified program line. If the condition is not met, the program proceeds to execute the next line in the program.</p> <p>Any two registers can be compared to each other, but the command does not do anything beyond comparing the register numerical values, as measured in native motor units. To ensure comparisons are meaningful, it is preferable to compare registers that hold the same type of information, in the same binary format.</p> <p>In the example above, two position registers are compared. Both hold position information, both measure position in encoder counts. Such a comparison will always yield meaningful, predictable results. For other types of registers, consult section 5.6.</p>

# 4.11 Expansion Module MAC00-R1/R3/R4

## 4.11.37 General hardware aspects

All internal and external main connections are shown in the illustration below.

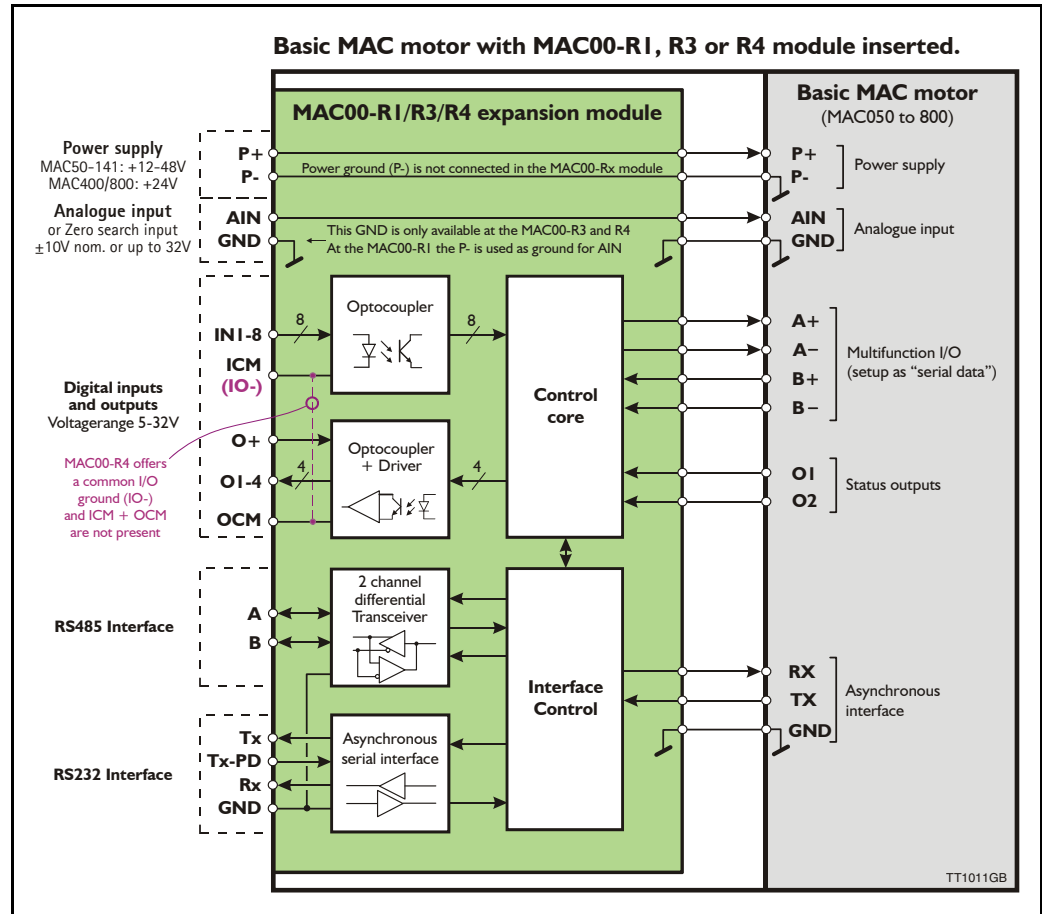

The following illustration shows how the I/O are internally connected.

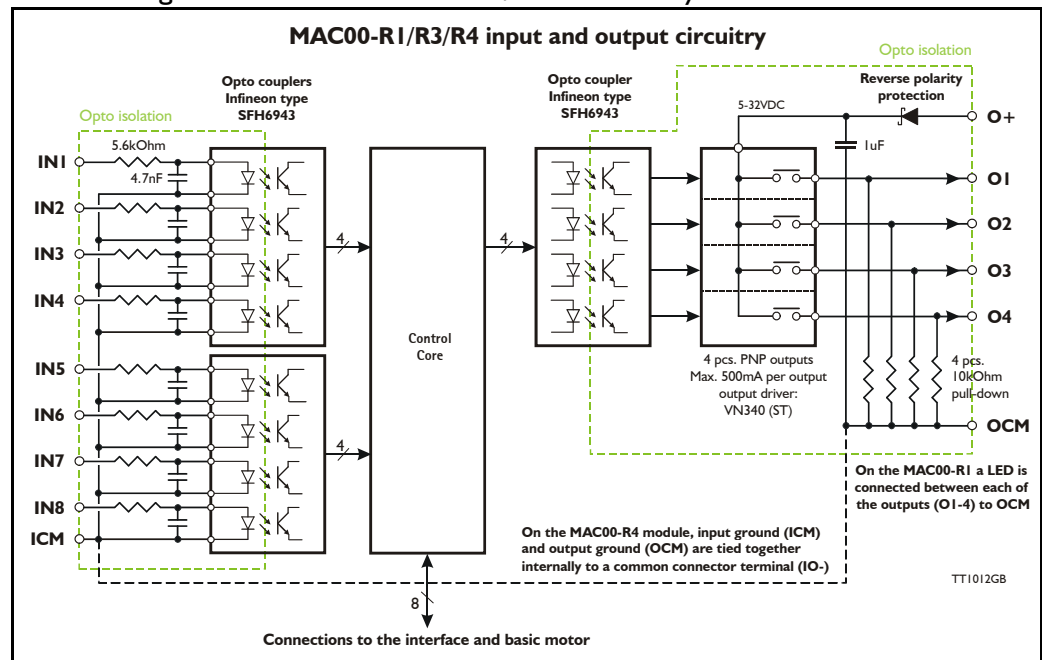

# 4.11 Expansion Module MAC00-R1/R3/R4

## 4.11.38 RS485 - General description when using a MAC00-Rx module

The RS485 offers more noise-immune communication compared to the RS232 interface. Up to 32 motors can be connected to the same line.

When connecting the RS485 interface to a central controller, the following rules must be followed:

- 1 Use twisted-pair cable
- 2 Use screened cable
- 3 Ensure that GND is also connected in order to assure the same potential between all the connected nodes.
- 4 Ensure that all units have a proper connection to safety ground (earth) in order to refer to the same potential.
- 5 The last unit in each end of the network must be terminated. Use a termination resistor in the range 120-220 Ohm between line A and B.
- 6 Ensure that the supply lines are connected individually in order to minimise the voltage drop between the motors.
- 7 Master Controller RS485 interface:  
If available, it is strongly recommended a type with optical isolation is used.

### Connectors:

Please read the individual description for the MAC00-R1, R3 or R4 to see the connector layout.

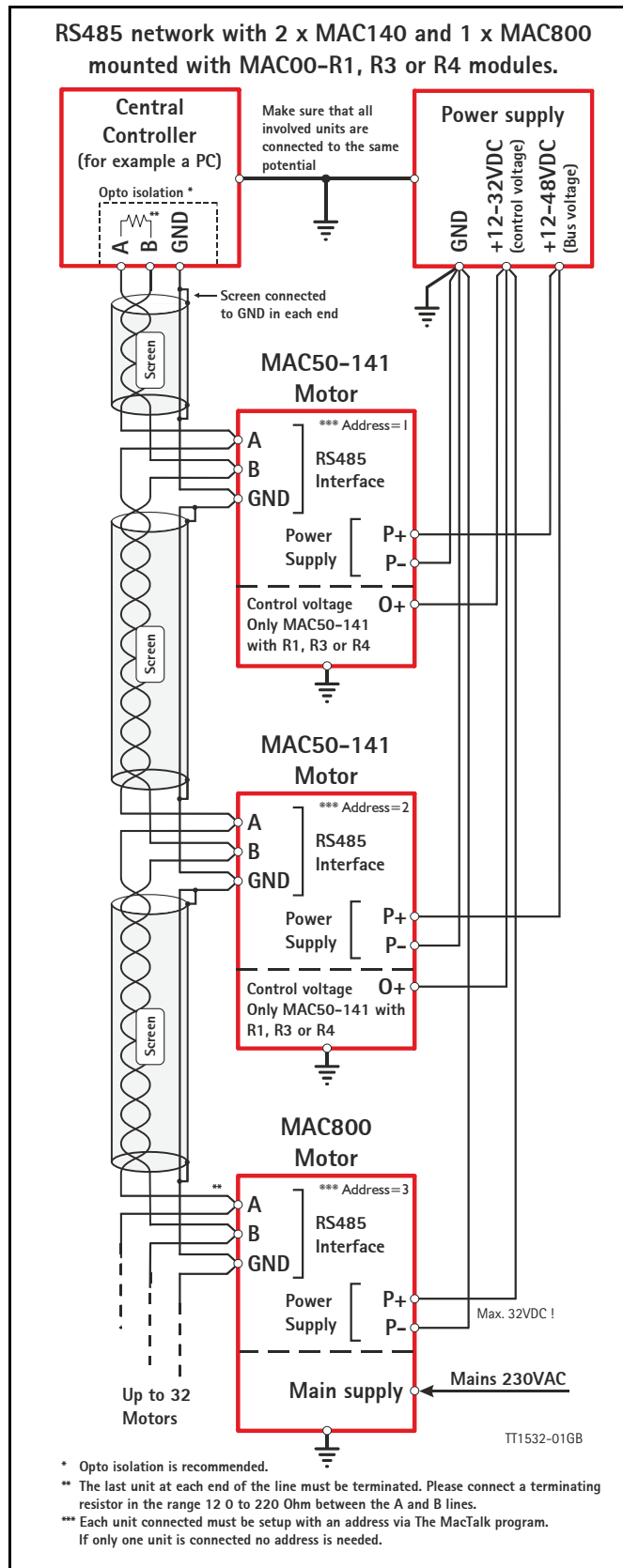

# 4.11 Expansion Module MAC00-R1/R3/R4

## 4.11.39 Expansion MAC00-R1 hardware description

The illustration below shows the I/O connections on the MAC00-R1 expansion module.

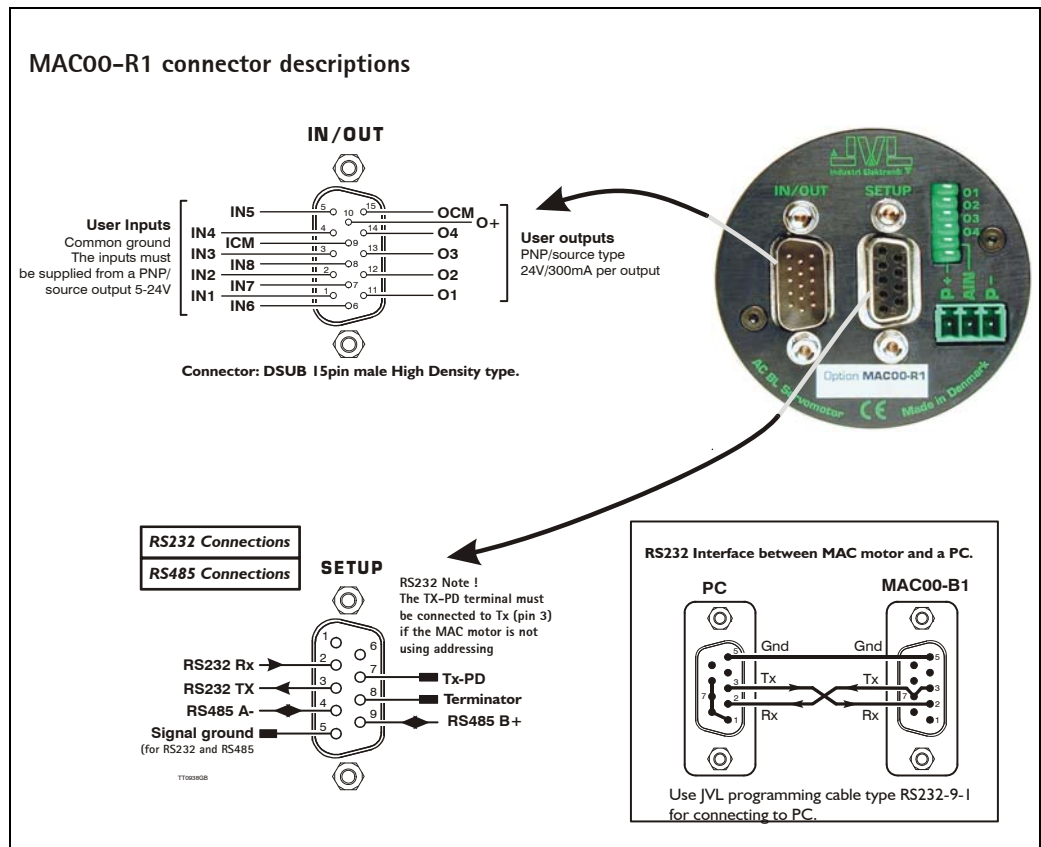

All inputs have a common ground ICM and all the outputs uses OCM as ground. O+ is the supply terminal for the output circuitry and must be supplied with a voltage from 6-32VDC. The outputs are short-circuit protected.

The input and output circuitry are optically isolated from each other and also from the other parts of the MAC00-R1 or R3.

## 4.11 Expansion Module MAC00-R1/R3/R4

### 4.11.40 Expansion MAC00-R3 hardware description

The illustration below shows the I/O connections on the MAC00-R3 expansion module.

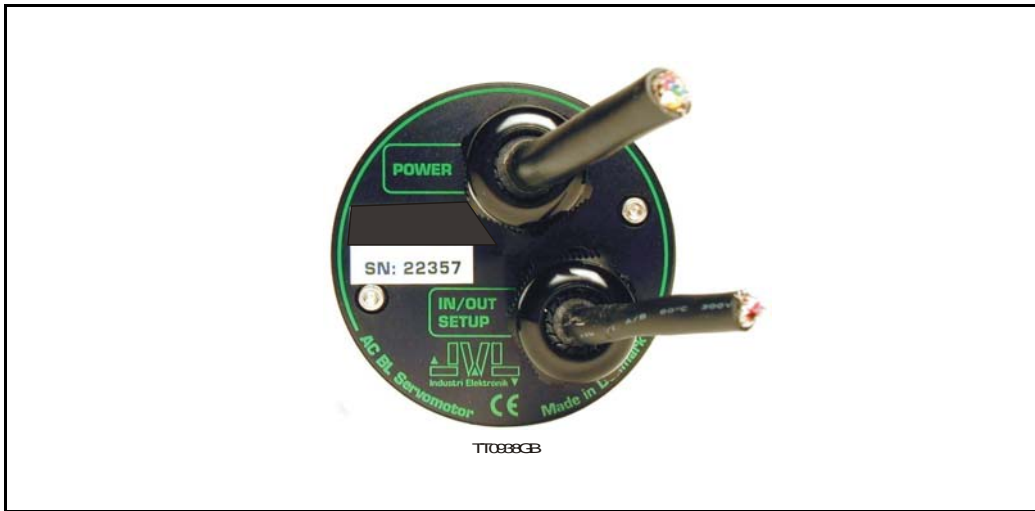

The MAC00-R3 expansion module is an industrial interface that mates with the standard MAC motor and offers a number of feature enhancements including:

- Protection IP67 if mounted on basic MAC motor (IP67 type: MAC050-141).
- Direct cable connection through sealed compression cable glands.
- Addition of a Zero switch input for locating a mechanical zero point of the actuator when used in position related modes.
- Miniature connectors (internal) for all signal lines including RS232/485 interface and Zero search switch. Molex 3.96mm connector for power supply.
- Full RS232 protocol support  
Note: The basic MAC motor is only equipped with a low-voltage serial interface that requires the use of the RS232-9-I-MAC option cable, which has integrated electronics to boost the voltage levels.
- Full RS485 protocol support for multipoint communication up to 100m.
- Sourcing (PNP) outputs for status signals O1 and O2 instead of sinking (NPN).

## 4.11 Expansion Module MAC00-R1/R3/R4

### 4.11.41 MAC00-R3 option with cables

The MAC00-R3 type number only covers the basic module without any cables.

If a number is added after the basic type number, for example MAC00-R3-10, this suffix indicates that the module is fitted with 2x10m of cable. 1 cable comprises the power supply and analogue input. The other cable covers all the signal lines, i.e. RS232, RS485, status outputs and multifunction I/O.

Power cable - Cable 1 - JVL type no. WG0302 (2m) or WG0320 (20m)

Power Supply		
Signal name	Description	Wire colour
P+	Positive supply terminal +12 to 48VDC	Red
P-	Negative supply terminal (ground)	Black (or white)
Screen	Screen to minimize noise	Screen (connected internally to P-)

Signal cable - Cable 2- JVL type no. WG0420 (20m).

Digital Inputs - Internal connector J2		
Signal name	Description	Wire colour
IN1	Digital input 1	Red/black
IN2	Digital input 2	Green/black
IN3	Digital input 3	Violet
IN4	Digital input 4	Violet/white
IN5	Digital input 5	Grey
IN6	Digital input 6	Grey/black
IN7	(Reserved)	Pink/black
IN8	(Reserved)	Black/white
ICM	Input ground. This ground is used for IN1 to IN8	Light green **
NC	Reserved for future features - Do not connect this wire.	White
Digital Outputs - including analogue input - Internal connector J4		
Signal name	Description	Wire colour
O+	Supply for outputs - Must be connected to an ext. supply.	Red/white
OCM	Output ground. This ground is used together with O1-O4	Green/white
O1	Digital output 1 - PNP output	Yellow/black
O2	Digital output 2 - PNP output	Blue/white
O3	Digital output 3 - PNP output	Orange/white
O4	Digital output 4 - PNP output	Brown/white
AIN I	Analogue input +/-10V (also used for <i>Zero search</i> sensor).	Pink
GND	I/O ground. This ground is shared with the input ground	Black
Interface - Internal connector J1		
Signal name	Description	Wire colour
TXPD	Transmit pull-down - connect with TX if addressing is not used	Red
TX	RS232 Transmit - If not used, do <b>NOT</b> connect ! Remember to connect with TXPD if addressing is not used	Green **
RX	RS232 Receive - If not used, do <b>NOT</b> connect !	Yellow
GND	Ground for RS232 and RS485	Blue
RS485 B+	RS485 - If not used, do <b>NOT</b> connect !	Orange
RS485 A-	RS485 - If not used, do <b>NOT</b> connect !	Brown
Cable Screen		
The cable-screen is internally connected to motor housing. Externally it must be connected to earth.		
Unused wire		
Orange/Black - is not used internally. It must be left unconnected.		

\*\* : The light green wire (ICM) can be difficult to distinguish from the green wire (TX) on some cables.

**Important:** Please note that the cables are a standard type. They are not recommended for use in cable chains or where the cable is repeatedly bent. If this is required, use a special robot cable (2D or 3D cable).

# 4.11 Expansion Module MAC00-R1/R3/R4

## 4.11.42 Connecting the RS232 interface of the MAC00-R3 module

The illustration below shows how to connect the MAC00-R3 directly to a PC COM port. The drawing is based on standard cables from JVL, types WG0402, WG0410 or WG0420. See also *Accessories, page 415* for a complete list of cables and connectors. Please remember to connect the TX and TX-PD wires from the MAC00-R3 together to achieve stable operation.

If the MAC motor is connected to the same RS232 line as other motors, the terminal TX-PD should only be connected on one of the motors.

If one of JVL's standard RS232 cables (RS232-9-1 or -n) is used between the DSUB connector shown and the PC com port, the RX and TX pins must be swapped since they cross in these standard cables.

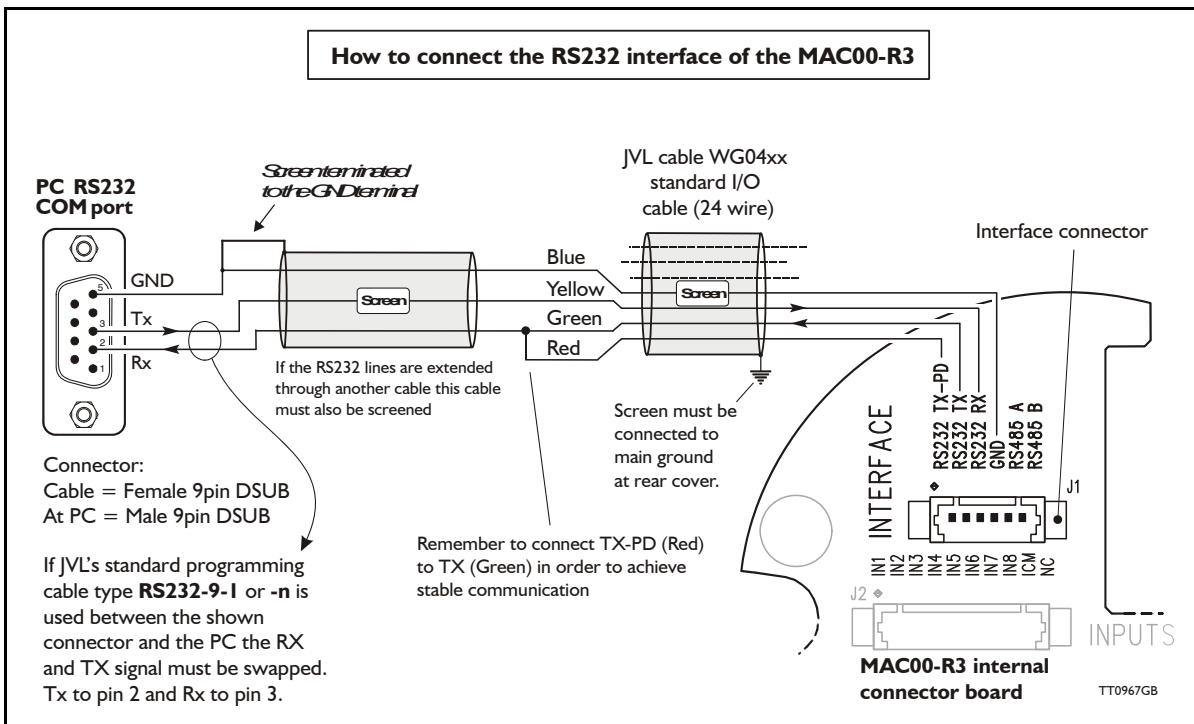



## 4.11 Expansion Module MAC00-R1/R3/R4

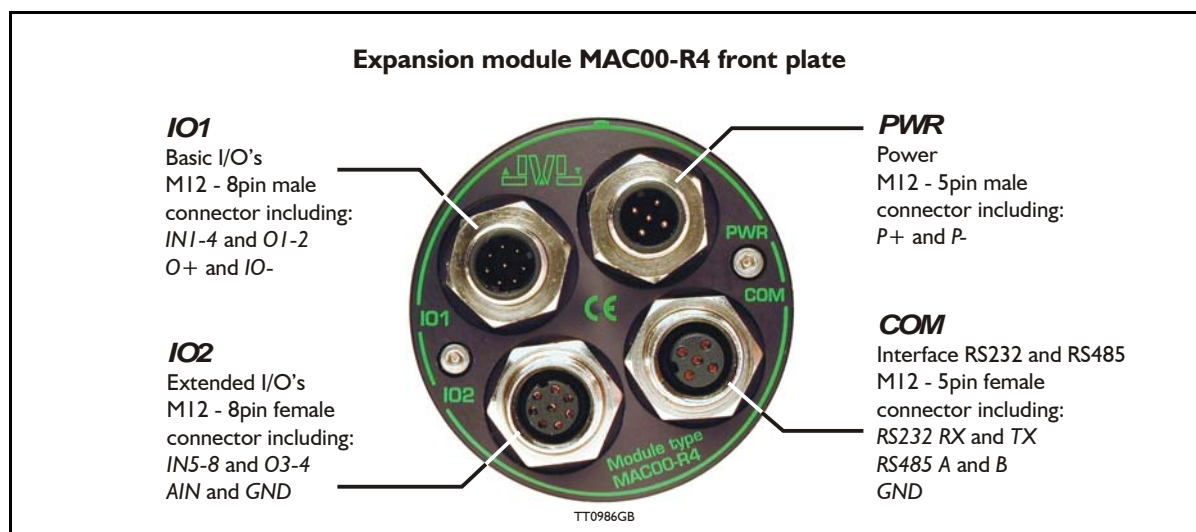

### 4.11.43 Expansion MAC00-R4 hardware description

The MAC00-R4 offers IP67 on MAC050-141 protection and M12 connectors which make it ideal for automation applications where no additional protection is desired. The M12 connectors offer solid mechanical protection and are easy to unplug compared to the R3 module which has cable glands. All the available signals are the same as used in the other R modules except for TX-PD which is converted into an internal dip-switch. The connector layout:

<b>"PWR" - Power input. M12 - 5-pin male connector</b>				
Signal name	Description	Pin no.	JVL Cable W11000M12 F5T05N	Isolation group
P+	Main supply +12-48VDC. Connect with pin 2 *	1	Brown	1
P+	Main supply +12-48VDC. Connect with pin 1 *	2	White	1
P-	Main supply ground. Connect with pin 5 *	3	Blue	1
Unused	Future option	4	Black	-
P-	Main supply ground. Connect with pin 3 *	5	Grey	1
* Note: P+ and P- is each available at 2 terminals. Make sure that both terminals are connected in order to split the supply current between 2 terminals and thereby avoid an overload of the connector.				
<b>"COM" - Interface RS232 and RS485. M12 - 5-pin female connector</b>				
Signal name	Description	Pin no.	JVL Cable W11000M12 M5T05N	Isolation group
RS232 Rx	RS232 interface receive terminal. Leave open if unused	1	Brown	1
RS232 Tx	RS232 interface transmit terminal. Leave open if unused. - <b>Important, see note1:</b>	2	White	1
RS485 B+	RS485 interface terminal. Leave open if unused	3	Blue	1
RS485 A-	RS485 interface terminal. Leave open if unused	4	Black	1
GND	Interface ground (same as main ground).	5	Grey	1

Note 1: See also *Dip switch for RS232 TxPD (Transmit pull-down)*, page 329

(Continued next page)

## 4.11 Expansion Module MAC00-R1/R3/R4

(Continued from previous page)

<b>"IO1" - Basic I/O's. M12 - 8-pin male connector.</b>				
Signal name	Description	Pin no.	JVL Cable W11000-M12 F8T05N	Isolation group
IN1	Digital input 1	1	White	2
IN2	Digital input 2	2	Brown	2
IN3	Digital input 3	3	Green	2
IN4	Digital input 4	4	Yellow	2
O1	Digital output 1 - PNP output	5	Grey	2
O2	Digital output 2 - PNP output	6	Pink	2
O+	Output supply +8-32VDC. Used for O1-4. Not used/necessary for using IN1-8	7	Blue	2
IO-	I/O ground. Used for IN1-8 and O1-4.	8	Red	2
<b>"IO2" - Extended I/Os. M12 - 8-pin female connector.</b>				
Signal name	Description	Pin no.	JVL Cable W11000-M12 M8T05N	Isolation group
IN5	Digital input 5	1	White	2
IN6	Digital input 6	2	Brown	2
IN7	Digital input 7	3	Green	2
IN8	Digital input 8	4	Yellow	2
O3	Digital output 3 - PNP output	5	Grey	2
O4	Digital output 4 - PNP output	6	Pink	2
AIN1	Analogue input +/-10V (also used for <i>Zero search</i> sensor).	7	Blue	1
GND	Ground for AIN. This ground is shared with the main ground	8	Red	1
<b>Cable Screen</b>				
Some standard cables with M12 connectors offer a screen around the cable. This screen on some cables is fitted to the outer metal at the M12 connector. When fitted to the MAC00-R4 module, this means that the screen will have contact with the complete motor housing and thereby also the power ground (main ground).				
<b>Isolation groups</b>				
The MAC00-R4 offers optical isolation at the digital inputs and outputs (IN1-8 and O1-4). The table above shows a number for each pin. This number refers to the isolation group to which the terminal is connected. Isolation group 1 means that the terminal refers to the main ground. Isolation group 2 means that the terminal refers to the I/O ground (IO-).				

### 4.11.44 Dip switch for RS232 TxPD (Transmit pull-down)

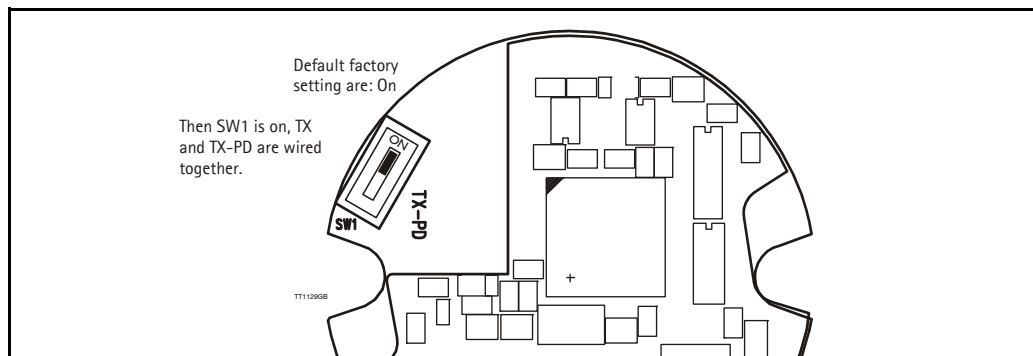







If the MAC motor is connected to the same RS232 line as other motors, the terminal TX-PD should only be connected on one of the motors.

## 4.11 Expansion Module MAC00-R1/R3/R4

### 4.11.45 Cables for the MAC00-R4

The following cables equipped with M12 connector can be supplied by JVL.

MAC00-R4 Connectors				Description	JVL Order no.	Photo
"IO1" 8-pin Male	"IO2" 8-pin Female	"COM" 5-pin Female	"PWR" 5-pin Male			
		X		RS232 Interface cable. Connects directly from MAC00-R4 to PC Length: 5m (197 inch)	RS232-M12-1-5-5	
			X	Cable (Ø5.5mm) with M12 female 5 pin connector loose ends 0.35mm <sup>2</sup> (22AWG) and screen. Length: 5m (197 inch)	WI1000-M12F5T05N	
			X	Same as above but 20m (787 inch)	WI1000-M12F5T20N	
		X		Cable with M12 male 5-pin connector loose wire ends 0.35mm <sup>2</sup> (22AWG) and screen. Length: 5m (197 inch).	WI1000-M12M5T05N See also type: RS232-M12-1-5-5	
		X		Same as above but 20m (787 inch)	WI1000-M12M5T20N	
X				Cable with M12 female 8-pin connector loose wire ends 0.22mm <sup>2</sup> (24AWG) and screen. Length: 5m (197 inch)	WI1000-M12F8T05N	
X				Same as above but 20m (787 inch)	WI1000-M12F8T20N	
	X			Cable with M12 male 8-pin connector loose wire ends 0.22mm <sup>2</sup> (24AWG) and screen. Length: 5m (197 inch)	WI1000-M12M8T05N	
	X			Same as above but 20m (787 inch)	WI1000-M12M8T20N	
<b>Protection caps. Optional if connector is not used, to protect from dust / liquids.</b>						
	X	X		IP67 protection cap for M12 female connector.	WI1000-M12FCAP1	
X			X	IP67 protection cap for M12 male connector.	WI1000-M12MCAP1	

**Important:** Please note that the cables are a standard type. They are not recommended for use in cable chains or where the cable is repeatedly bent. If this is required, use a special robot cable (2D or 3D cable).

See also *Accessories*, page 415



# 5.1

# Technical Data

Only MAC050 to I41

General		All data are specified for the MAC motor only, i.e. without any expansion module mounted.			
Technology	AC-servomotor (brushless) with built-in 1024 PPR encoder, hall sensors and 3-phase servo amplifier/controller				
Controller capacity		MAC050	MAC095	MAC140	MAC141
	Rated output @4000 RPM	46W	92W	134W	134W
	Rated Torque RMS Nm/(oz-in)	0.11 / (15.6)	0.22 / (31.2)	0.32 / (45.3)	0.48 / (68)
	Peak Torque Nm/(oz-in)	0.32 / (45.3)	0.62 / (88)	0.90 / (127.5)	1.59 / (225.2)
	Torque @200RPM with 20:1 gear. Nm/(oz-in)	2.0 / (283)	4.1 / (581)	6.0 / (850)	9.0 / (1275)
	Inertia kgcm <sup>2</sup> / (oz-in-sec <sup>2</sup> )	0.075(0.0011)	0.119(0.0017)	0.173(0.0025)	0.227(0.0032)
	Maximum angular acceleration	85300rad/sec <sup>2</sup>	85300rad/sec <sup>2</sup>	85300rad/sec <sup>2</sup>	85300rad/sec <sup>2</sup>
	Length mm/(inch)	112/(4.409)	131/(5.157)	153/(6.024)	172/(6.772)
	Weight (kg) (without expansion module)	0.60	0.85	1.10	1.33
Speed range	0-4000RPM with full torque @48VDC. Max 4000 RPM (0-2700RPM for MAC141)				
Amplifier control system	Sinusoidal wave PWM control. 15.75kHz switching				
Filter	4.th. order filter with only one inertia load factor parameter to be adjusted. Expert tuning also available				
Feedback	Incremental A and B encoder 4096 CPR. (Physical 1024 PPR)				
Input power supply	Single supply 12-48VDC (absolute max=50VDC. Power consumption with no load: Active/not active = 10/8W)				
Current consumption		MAC050	MAC095	MAC140	MAC141
	Avg. current consump. @ 48VDC/Nom. load (ADC)	2 (4000RPM)	4 (4000RPM)	6 (4000RPM)	6 (2700RPM)
	Avg. current consump. @ 24VDC/Nom. load (ADC)	2 (2000RPM)	4 (2000RPM)	6 (2000RPM)	6 (1350RPM)
	Peak supply current (worst case)	6A peak	12A peak	16A peak	16A peak
Control modes	<ul style="list-style-type: none"> <li>* ±10V Speed and Torque. A+B encoder outputs</li> <li>* Pulse/direction and 90° phase shifted A++B (Incremental)</li> <li>* RS422 or RS232 (5V) position and parameter commands</li> <li>* Gear mode with analogue input speed offset + different options</li> <li>* Sensor <i>Zero search</i> or mechanical <i>Zero search</i></li> </ul>				
Flange and shaft dimension	NEMA23 compatible. Front: 58 x 58mm. Rear: Ø58. Shaft Ø6.35mm				
<b>POSITION</b> (pulse inputs)					
Command input pulse	Pulse/direction or 90° phase shifted A+B. RS422. Logic 0=<2.0V. Logic 1=>3.0V. Max voltage at A+, A-, B+ and B- = 5.5V.				
Input frequency	0-2.5MHz or 0-150kHz with input filter				
Electronic gear	A/B: A=-10000 to 10000, B=1 to 10000. Simulation of all step resolutions for easy replacement of step motor systems.				
Follow error register	32 bit				
In position width	0-32767 pulses				
Position range	32 bit. Infinity, Flip over at ±2 <sup>31</sup> pulses.				
<b>POSITION</b> (serial communication)					
Communication facility	From PLC, PC etc via RS422 or asynchronous serial port RS232 with special cable. MacTalk JVL commands, special commands with high security.				
Communication Baud-rate	19200 bit/sec. (19.2kbaud)				
Position range	±67.000.000				
Speed range	0-4000 RPM. Digital resolution 0.477 RPM				
Acceleration range	248 - 397.364 RPM/sec				
Addressing	Point to point on RS422. Up to 32 units on the same serial RS232/RS485 interface with built-in expansion module. Address range 1-254				
Number of parameters.	Standard 85. With MacRegIO software 156 (Only for experts)				
Speed variance	Max. ±4 RPM variance between command and actual speed.				
<b>SPEED/ TORQUE</b>					
Analogue speed/torque input.	9 bit + sign. Nom. input voltage ±10V. 10kOhm input resistance. Voltage range max. -10 to +32VDC. Offset typical ±50mV.				
Analogue input tolerance	Typical ±1%. Max. 5% (Possible to make software adjustment to minimize gain and offset errors)				
Sampling rate at analogue input	521 Hz				
Encoder output signals	A+,A-,B+,B-, RS422. Line driver 5V outputs (SN75176). 90° Phase shifted.				
Analogue speed input	+voltage -> CW rotation. Shaft view				
Zero speed determination.	0 - rated speed.				
Speed variance at rated speed	Initial error @20°C: ±0,5%		Power Supply: ±10%: 0.0%		
	Load 0-300%: ±0.0%		Ambient temperature 0-40°C: ±0,1%		
Torque limit in speed mode	0-300% by parameter				
Analogue torque input	+voltage (positive torque) -> CW rotation. Shaft view				
Torque control accuracy	±10% @ 20°C (Reproducibility)				
<b>VARIOUS</b>					
Electromechanical brake	This option is not available on these motor sizes. Use the MAB23x - see <i>Brakes and shaft reinforcement, page 416</i>				
Regenerative	Integrated power dump. 3W can be absorbed continuously. External attachment is possible				
Protective functions.	Error trace back. Overload (I <sup>T</sup> ), Regenerative overload, follow error, function error, regenerative overload (over voltage), software position limit. Abnormality in flash memory, under voltage, over current.				
LED functions	Power (Green LED), Error (Red LED). Note that the LED's are only visible when no module is mounted.				
Output signals	2 general purpose NPN <32V/25 mA outputs. Error and In position.				
Zero search	1: Automatic <i>Zero search</i> with sensor connected to input (2 formats) 2: Mechanical <i>Zero search</i> without sensor. (Torque controlled)				
Shaft load maximum	Radial load: 75N (20mm from flange). Axial load: 15N.				
Leakage current to earth	Not relevant. Supply ground (P-) is hardwired to earth and motor housing				
Standards	CE approved / UL pending				
Protection	IP42 or IP67				
Usage / Storage Temperature	Ambient 0 to +40°C (32-104°F) / -20 to +85°C. (-4 to 185 °F) (Humidity 90%).				

# 5.1

# Technical Data

**Only MAC400**

General		All data are specified for the MAC motor only, i.e. without any expansion module mounted.		
Technology	AC-servomotor (brushless) with built-in 2048 PPR encoder, hall sensors and 3 phase servo amplifier/controller			
Controller capacity		-	MAC400-D2 & -D3	MAC400-D5 & -D6 (w/brake)
	Rated output @3000 RPM	-	400W	400W
	Rated Torque RMS / Peak Torque	-	1.27Nm / 3.8Nm	1.27Nm / 3.8Nm
	Inertia (kgcm <sup>2</sup> )	-	0.34 (kgcm <sup>2</sup> )	0.36 (kgcm <sup>2</sup> )
	Maximum angular acceleration	-	114706 rad/sec <sup>2</sup> (1095361 RPM/sec)	108333 rad/sec <sup>2</sup> (1034504 RPM/sec)
	Length	-	191mm	225mm
	Weight (without expansion module)	-	2.3kg	2.8kg
	Audible noise level (measured in 30cm distance)	-	-	(to be defined) dB(A)
Backlash (when brake is activated)	-	-	< ±1 degree	
Speed range	0-3000RPM with nom. torque. (max 3500RPM shortterm). Speed protection trips at >4300RPM. Motor will shut down.			
Amplifier control system	Sinusoidal wave PWM control. 20kHz switching, optional 10kHz			
Filter	6.th. order filter with only one inertia load factor parameter to be adjusted.			
Feedback	Incremental A and B encoder 8192 CPR. (Physical 2048 PPR). Optional multturn absolute encoder.			
Input power supply	115/230AC (±10%) for main power circuit. 18-32VDC for control circuit. Consumption at 115-230VAC - see power supply section. Control circuitry consumption: MAC400D1, 2 and 3 (wo/brake) = Typical 0.22A @ 24VDC(5.3W). Control circuitry consumption: MAC400D4, 5 and 6 (w/brake) = Typical 0.58A @ 24VDC(14W).			
Control modes	<ul style="list-style-type: none"> <li>* ±10V Speed and Torque. A+B encoder outputs</li> <li>* Pulse/direction and 90° phase shifted A++B (Incremental)</li> <li>* RS422 or RS232 (5V) position and parameter commands</li> <li>* Gear mode with analogue input speed offset + different options</li> <li>* Sensor Zero search or mechanical Zero search</li> </ul>			
Flange and shaft dimension	Front: 60x60mm. Rear: 63x115mm. Shaft Ø14mm			
<b>POSITION</b> (pulse inputs)				
Command input pulse	Pulse/direction or 90° phase shifted A+B. RS422			
Input frequency	0-8 MHz. 0-1 MHz with input filter			
Electronic gear	A/B: A= -10000 to 10000, B=1 to 10000. Simulation of all step resolutions.			
Follow error register	32 bit			
In position width	0-32767 pulses			
Position range	32 bit. Infinity, Flip over at ±2 <sup>31</sup> pulses.			
<b>POSITION</b> (serial communication)				
Communication facility	From PLC, PC etc via RS422 or asynchronous serial port RS232 with special cable. MacTalk JVL commands, special commands with high security.			
Communication Baud-rate	19200 bit/sec. (19.2kbaud)			
Position range	±67 000 000			
Speed range	0-3000 RPM.			
Digital resolution	0.3606 RPM			
Acceleration range	250 - 444.675 RPM/sec			
Addressing	Point to point on RS422. Up to 32 units on the same serial RS232/RS485 interface with built-in expansion module. Address range 1-254			
Number of parameters.	Standard 85. With MacRegIO software 156 (Only for experts)			
Speed variance	Max ±4 RPM variance between command and actual speed.			
<b>SPEED/ TORQUE</b>				
Analogue speed/torque input.	11bit + sign. Nom. input voltage ±10V. 10kOhm input resistance. Voltage range max. -10 to +32VDC. Offset typical ±50mV.			
Sampling rate at analogue input	750 Hz			
Encoder output signals	A+, A-, B+, B-, RS422. Line driver Typical 1.1 - 3.7 Volt outputs (SN75176). 90° Phase shifted.			
Analogue speed input	+voltage -> CW rotation. Shaft view			
Zero speed determination.	0 - rated speed.			
Speed variance at rated speed	Initial error @20°C: ±0.0%	Power Supply: ±10%: 0.0%		
	Load 0-300%: ±0.0%	Ambient temperature 0-40°C: ±0.0005% (±50ppm)		
Torque limit in speed mode	0-300% by parameter			
Analogue torque input	+voltage (positive torque) -> CW rotation. Shaft view			
Torque control accuracy	±10% @ 20°C (Reproducibility)			
<b>VARIOUS</b>				
Electromechanical brake	Optional feature. The brake is activated automatically when an unrecoverable error situation occur.			
Regenerative	Integrated power dump. External attachment is possible			
Protective functions.	Error trace back. Overload (I <sup>2</sup> T), Regenerative overload, follow error, function error, regenerative overload (over voltage), software position limit. Abnormality in flash memory, under voltage, over current, temperature too high.			
LED functions	Power (Green LED), Error (Red LED). Note that the LED's are only visible when no module is mounted.			
Output signals	3 general purpose NPN 30V/25 mA outputs. Error and In position.			
Zero search	1: Automatic Zero search with sensor connected to input (2 formats) 2: Mechanical Zero search without sensor. (Torque controlled)			
Shaft load maximum	Radial load: 24.5kg (13.5mm from flange). Axial load: 9.8kg.			
Optional brake(-D5 and -D6 option)	Controlled automatic or from input. 1.3Nm, inertia 0.22cm <sup>2</sup> , turn on time: 50ms, turn off time: 15ms			
Rated power rate. (motor)	50.0 kW/s			
Mechanical time constant. (motor)	0.59±10% ms			
Electrical time constant. (motor)	3.5±10% ms			
Leakage current to earth	Less than 3 mA @ 50 Hz			
Standards	CE approved / UL File: E254947			
Protection	IP55 or IP66			
Usage / Storage Temperature	Ambient 0 to +40°C (32-104°F) Storage (power not applied): -20 to +85°C. (-4 to 185°F) (Humidity 90%). Temperature warning is given before reaching max. Temperature shut down and error message generated at 84°C (183F).			

# 5.1

# Technical Data

Only MAC402

General		All data are specified for the MAC motor only, i.e. without any expansion module mounted.	
Technology	AC-servomotor (brushless) with built-in 2048 PPR encoder, hall sensors and 3 phase servo amplifier/controller		
Controller capacity		-	MAC402-D2 & -D3
	Rated output @3000 RPM	-	400W
	Rated Torque RMS / Peak Torque	-	1.27Nm / 3.8Nm
	Inertia (kgcm <sup>2</sup> )	-	0.34 (kgcm <sup>2</sup> )
	Maximum angular acceleration	-	114359 rad/sec <sup>2</sup> (1092048 RPM/sec)
	Length	-	191mm
	Weight (without expansion module)	-	2.3kg
	Audible noise level (measured in 30cm distance)	-	(to be defined) dB(A)
	Backlash (when brake is activated)	-	< ±1 degree
Speed range	0-3000RPM with nom. torque. (max 3500RPM shortterm). O.Speed protection trips at >4300RPM. Motor will shut down.		
Amplifier control system	Sinusoidal wave PWM control. 20kHz switching		
Filter	6.th. order filter with only one inertia load factor parameter to be adjusted. Expert tuning also available for professionals.		
Feedback	Incremental A and B encoder 8192 CPR. (Physical 2048 PPR). Optional multiturn absolute encoder.		
Input power supply	Nominal 12-48VDC (±10%) for main power circuit. Recommended also for 12V battery applications. Consumption at 12-48VDC - see power supply section. 18-32VDC for control circuit. Control circuitry consumption: MAC400D1, 2 and 3 (wo/brake) = Typical 0.22A @ 24VDC(5.3W). Control circuitry consumption: MAC400D4, 5 and 6 (w/brake) = Typical 0.58A @ 24VDC(14W).		
Control modes	<ul style="list-style-type: none"> <li>* ±10V Speed and Torque. A+B encoder outputs</li> <li>* Pulse/direction and 90° phase shifted A++B (Incremental)</li> <li>* RS422 or RS232 (5V) position and parameter commands</li> <li>* Gear mode with analogue input speed offset + different options</li> <li>* Sensor <i>Zero search</i> or mechanical <i>Zero search</i></li> </ul>		
Flange and shaft dimension	Front: 60x60mm. Rear: 63x115mm. Shaft Ø14mm		
<b>POSITION (pulse inputs)</b>			
Command input pulse	Pulse/direction or 90° phase shifted A+B. RS422		
Input frequency	0-8 MHz. 0-1 MHz with input filter		
Electronic gear	A/B: A= -10000 to 10000, B=1 to 10000. Simulation of all step resolutions.		
Follow error register	32 bit		
In position width	0-32767 pulses		
Position range	32 bit. Infinity, Flip over at ±2 <sup>31</sup> pulses.		
<b>POSITION (serial communication)</b>			
Communication facility	From PLC, PC etc via RS422 or asynchronous serial port RS232 with special cable. MacTalk JVL commands, special commands with high security.		
Communication Baud-rate	19200 bit/sec. (19.2kBaud)		
Position range	±67 000 000		
Speed range	0-3000 RPM.		
Digital resolution	0.3606 RPM		
Acceleration range	250 - 444.675 RPM/sec		
Addressing	Point to point on RS422. Up to 32 units on the same serial RS232/RS485 interface with built-in expansion module. Address range 1-254		
Number of parameters.	Standard 85. With MacRegIO software 156 (Only for experts)		
Speed variance	Max ±4 RPM variance between command and actual speed.		
<b>SPEED/ TORQUE</b>			
Analogue speed/torque input.	11bit+sign. nom. input voltage ±10V. 10kOhm input resistance. Voltage range max. -10 to +32VDC. Offset typical ±50mV.		
Sampling rate at analogue input	750 Hz		
Encoder output signals	A+,A-,B+,B-, RS422. Line driver Typical 1.1 - 3.7 Volt outputs (SN75176). 90° Phase shifted.		
Analogue speed input	+voltage -> CW rotation. Shaft view		
Zero speed determination.	0 - rated speed.		
Speed variance at rated speed	Initial error @20°C: ±0.0%	Power Supply: ±10%: 0.0%	
	Load 0-300%: ±0.0%	Ambient temperature 0-40°C: ±0,0005% (±50ppm)	
Torque limit in speed mode	0-300% by parameter		
Analogue torque input	+voltage (positive torque) -> CW rotation. Shaft view		
Torque control accuracy	±10% @ 20°C (Reproducibility)		
<b>VARIOUS</b>			
Electromechanical brake	Optional feature. The brake is activated automatically when an unrecoverable error situation occur.		
Regenerative	Integrated power dump. External attachment is possible		
Protective functions.	Error trace back. Overload (PT), Regenerative overload, follow error, function error, regenerative overload (over voltage), software position limit. Abnormality in flash memory, under voltage, over current, temperature too high.		
LED functions	Power (Green LED), Error (Red LED). Note that the LED's are only visible when no module is mounted.		
Output signals	3 general purpose NPN 30V/25 mA outputs. Error and In position.		
Zero search	1: Automatic <i>Zero search</i> with sensor connected to input (2 formats) 2: Mechanical <i>Zero search</i> without sensor. (Torque controlled)		
Shaft load maximum	Radial load: 24.5kg (13.5mm from flange). Axial load: 9.8kg.		
Optional brake(-D4 option)	Controlled automatic or from input. 1.3Nm, inertia 0.22cm <sup>2</sup> , turn on time: 50ms, turn off time: 15ms		
Rated power rate. (motor)	50.0 kW/s		
Mechanical time constant. (motor)	0.59±10% ms		
Electrical time constant. (motor)	3.5±10% ms		
Leakage current to earth	Not relevant. Supply ground is hardwired to earth and motor housing		
Standards	CE approved / UL File: E254947		
Protection	IP55 or IP66		
Usage / Storage Temperature	Ambient 0 to +40°C (32-104°F)/ Storage (power not applied): -20 to +85°C. (-4 to 185°F) (Humidity 90%). Temperature warning is given before reaching max. Temperature shut down and error message generated at 84°C (183F).		

# 5.1

# Technical Data

Only MAC800

General		All data are specified for the MAC motor only, i.e. without any expansion module mounted.		
Technology	AC-servomotor (brushless) with built-in 2000 PPR encoder, hall sensors and 3 phase servo amplifier/controller			
Controller capacity			MAC800-D2/-D3	MAC800-D5/-D6 (w. brake)
	Rated output @3000 RPM	-	746W	746W
	Rated Torque RMS / Peak Torque	-	2.38Nm / 6.8Nm	2.38Nm / 6.8Nm
	Inertia (kgcm <sup>2</sup> )	-	0.91 (kgcm <sup>2</sup> )	1.13 (kgcm <sup>2</sup> )
	Maximum angular acceleration	-	(TBD) rad/sec <sup>2</sup>	(TBD) rad/sec <sup>2</sup>
	Length	-	170mm	210mm
	Weight (without expansion module)	-	3.5kg	4.3kg
	Audible noise level (measured in 30cm distance)	-	-	65 dB(A)
Backlash (when brake is activated)	-	-	±0.5 degree	
Speed range	0-3000RPM with full torque. Max 3500 RPM. Overspeed protection if speed >3600 = Motor will go in passive mode			
Amplifier control system	Sinusoidal wave PWM control. 20kHz switching			
Filter	6.th. order filter with only one inertia load factor parameter to be adjusted. Expert tuning also available for professionals.			
Feedback	Incremental A and B encoder 8000 CPR. (Physical 2000 PPR). Optional multiturn absolute encoder.			
Input power supply	115/230VAC (±10%) for main power circuit. 18-32VDC for control circuit. Consumption at 115-230VAC - see power supply section. Control circuitry consumption: MAC800D1, 2 and 3 (wo/brake) =0.25A @ 24VDC(6W). Control circuitry consumption: MAC800D4, 5 and 6 (w/brake) =0.75A @ 24VDC(18W).			
Control modes	<ul style="list-style-type: none"> <li>* ±10V Speed and Torque. A+B encoder outputs</li> <li>* Pulse/direction and 90° phase shifted A++B (Incremental)</li> <li>* RS422 or RS232 (5V) position and parameter commands</li> <li>* Gear mode with analogue input speed offset + different options</li> <li>* Sensor Zero search or mechanical Zero search</li> </ul>			
Flange and shaft dimension	Front: 80x80mm. Rear: 80x113mm. Shaft Ø19mm			
<b>POSITION</b> (pulse inputs)				
Command input pulse	Pulse/direction or 90° phase shifted A+B. RS422			
Input frequency	0-8 MHz. 0-1 MHz with input filter			
Electronic gear	A/B: A= -10000 to 10000, B=1 to10000. Simulation of all step resolutions.			
Follow error register	32 bit			
In position width	0-32767 pulses			
Position range	32 bit. Infinity, Flip over at ±2 <sup>31</sup> pulses.			
<b>POSITION</b> (serial communication)				
Communication facility	From PLC, PC etc via RS422 or asynchronous serial port RS232 with special cable. MacTalk JVL commands, special commands with high security.			
Communication Baud-rate	19200 bit/sec. (19.2kBaud)			
Position range	±67 000 000			
Speed range	0-3000 RPM.			
Digital resolution	0.3606 RPM			
Acceleration range	250 - 444.675 RPM/sec			
Addressing	Point to point on RS422. Up to 32 units on the same serial RS232/RS485 interface with built-in expansion module. Address range 1-254			
Number of parameters.	Standard 85. With MacRegIO software 156 (Only for experts)			
Speed variance	Max ±4 RPM variance between command and actual speed.			
<b>SPEED/ TORQUE</b>				
Analogue speed/torque input.	11bit + sign. Nom. input voltage ±10V. 10kOhm input resistance. Voltage range max. -10 to +32VDC. Offset typical ±50mV.			
Sampling rate at analogue input	750 Hz			
Encoder output signals	A+,A-,B+,B-, RS422. Line driver Typical 1.1 - 3.7 Volt outputs (SN75176). 90° Phase shifted.			
Analogue speed input	+voltage -> CW rotation. Shaft view			
Zero speed determination.	0 - rated speed.			
Speed variance at rated speed	Initial error @20°C: ±0.0%	Power Supply: ±10%: 0.0%		
	Load 0-300%: ±0.0%	Ambient temperature 0-40°C: ±0,0005% (±50ppm)		
Torque limit in speed mode	0-300% by parameter			
Analogue torque input	+voltage (positive torque) -> CW rotation. Shaft view			
Torque control accuracy	±10% @ 20°C (Reproducibility)			
<b>VARIOUS</b>				
Electromechanical brake	Optional feature. The brake is activated automatically when an unrecoverable error situation occur.			
Regenerative	Integrated power dump. External attachment is possible			
Protective functions.	Error trace back.Overload (I <sup>2</sup> T), Regenerative overload, follow error, function error, regenerative overload (over voltage), software position limit. Abnormality in flash memory, under voltage, over current, temperature too high.			
LED functions	Power (Green LED), Error (Red LED). Note that the LED's are only visible when no module is mounted.			
Output signals	3 general purpose NPN 30V/25 mA outputs. Error and In position.			
Zero search	1: Automatic Zero search with sensor connected to input (2 formats) 2: Mechanical Zero search without sensor. (Torque controlled)			
Shaft load maximum	Radial load: 18kg (20mm from flange). Axial load: 11kg.			
Optional brake(-D4 option)	Controlled automatic or from input. 3.0Nm, inertia 0.22cm <sup>2</sup> , turn on time: 50ms, turn off time: 15ms			
Rated power rate. (motor)	62.8 kW/s			
Mechanical time constant. (motor)	0.428±10% ms			
Electrical time constant. (motor)	4.122±10% ms			
Leakage current to earth	Less than 3 mA @ 50 Hz			
Standards	CE approved / UL File: E254947			
Protection	IP55 or IP66			
Usage / Storage Temperature	Ambient 0 to +40°C (32-104°F)/ -20 to +85°C. (-4 to 185°F) (Humidity 90%). Error on 75°C (167°F) Temperature shut down and error message generated at 73°C (163°F). The heatsink fan starts at 55°C (131F).			



# 5.1

# Technical Data

Only MAC1500

<b>General</b>	<b>All data are specified for the MAC motor only, i.e. without any expansion module mounted.</b>			
Technology	AC-servomotor (brushless) with built-in 2048 PPR encoder, hall sensors and 3 phase servo amplifier/controller			
Controller capacity		-	MAC1500-D2 or D3	MAC1500-D5 or D6 (w. brake)
	Rated output @3000 RPM	-	1500W	1500W
	Rated Torque RMS / Peak Torque	-	4.78Nm / 14.33Nm	4.78Nm / 14.33Nm
	Inertia	-	13.96 kgcm <sup>2</sup>	14.1 kgcm <sup>2</sup>
	Maximum angular acceleration	-	(TBD) rad/sec <sup>2</sup>	(TBD) rad/sec <sup>2</sup>
	Length	-	250mm / 9.843"	305.86mm / 12.042"
	Weight (without expansion module)	-	10.95kg	13.15kg
	Audible noise level (measured in 30cm distance)	-	-	65 dB(A)
Backlash (when brake is activated)	-	-	±0.5 degree	
Speed range	0-3000RPM with full torque. Max 3500 RPM. Overspeed protection if speed >3600 = Motor will go in passive mode			
Amplifier control system	Sinusoidal wave PWM control. 5kHz switching			
Filter	6.th. order filter with only one inertia load factor parameter to be adjusted. Expert tuning also available for professionals.			
Feedback	Incremental A and B encoder 8192 CPR. (Physical 2048 PPR/lines per rev.). Optional multturn absolute encoder.			
Input power supply	3 phase supply 400 to 480AC for driver circuit. Absolute max 550VAC ! 18-32VDC for control circuit. Control circuitry consumption: MAC1500-D1, 2 and 3 (wo/brake) =0.3A @ 24VDC(8W). Control circuitry consumption: MAC1500-D4, 5 and 6 (w/brake) =1.2A @ 24VDC(24W).			
Control modes	<ul style="list-style-type: none"> <li>* ±10V Speed and Torque. A+B encoder outputs</li> <li>* Pulse/direction and 90° phase shifted A++B (Incremental)</li> <li>* RS422 or RS232 (5V) position and parameter commands</li> <li>* Gear mode with analogue input speed offset + different options</li> <li>* Sensor <i>Zero search</i> or mechanical <i>Zero search</i></li> </ul>			
Flange and shaft dimension	Front: 130x130mm. Rear: 130x203mm(excl. connectors). Shaft Ø24.0mm +0/-0.013mm			
<b>POSITION</b> (pulse inputs)				
Command input pulse	Pulse/direction or 90° phase shifted A+B. RS422			
Input frequency	0-8 MHz. 0-1 MHz with input filter			
Electronic gear	A/B: A= -10000 to 10000, B=1 to10000. Simulation of all step resolutions.			
Follow error register	32 bit			
In position width	0-32767 pulses			
Position range	32 bit. Infinity, Flip over at ±2 <sup>31</sup> pulses.			
<b>POSITION</b> (serial communication)				
Communication facility	From PLC, PC etc via RS422 or asynchronous serial port RS232 with special cable. MacTalk JVL commands, special commands with high security.			
Communication Baud-rate	19200 bit/sec. (19.2kBaud)			
Position range	±67 000 000			
Speed range	0-3000 RPM.			
Digital resolution	0.3606 RPM			
Acceleration range	250 - 444.675 RPM/sec			
Addressing	Point to point on RS422. Up to 32 units on the same serial RS232/RS485 interface with built-in expansion module. Address range 1-254			
Number of parameters.	Standard 85. With MacRegIO software 156 (Only for experts)			
Speed variance	Max ±4 RPM variance between command and actual speed.			
<b>SPEED/ TORQUE</b>				
Analogue speed/torque input.	11bit + sign. Nom. input voltage ±10V. 10kOhm input resistance. Voltage range max. -10 to +32VDC. Offset typical ±50mV.			
Sampling rate at analogue input	750 Hz			
Encoder output signals	A+,A-,B+,B-, RS422. Line driver Typical 1.1 - 3.7 Volt outputs (Driver: SN75176). 90° Phase shifted.			
Analogue speed input	+voltage -> CW rotation. Shaft view			
Zero speed determination.	0 - rated speed.			
Speed variance at rated speed	Initial error @20°C: ±0,0%	Power Supply: ±10%: 0.0%		
	Load 0-300%: ±0.0%	Ambient temperature 0-40°C: ±0,0005% (±50ppm)		
Torque limit in speed mode	0-300% by parameter			
Analogue torque input	+voltage (positive torque) -> CW rotation. Shaft view			
Torque control accuracy	±10% @ 20°C (Reproducibility)			
<b>VARIOUS</b>				
Electromechanical brake	Optional feature. The brake is activated automatically when an unrecoverable error situation occur.			
Regenerative	Integrated power dump. External attachment is possible			
Protective functions.	Error trace back.Overload (I <sup>PT</sup> ), Regenerative overload, follow error, function error, regenerative overload (over voltage), software position limit. Abnormality in flash memory, under voltage, over current, temperature too high.			
LED functions	Power (Green LED), Error (Red LED). Note that the LED's are only visible when no module is mounted.			
Output signals	3 general purpose NPN 30V/25 mA outputs. Error and In position.			
Zero search	1: Automatic <i>Zero search</i> with sensor connected to input (2 formats) 2: Mechanical <i>Zero search</i> without sensor. (Torque controlled)			
Shaft load maximum	Radial load: xxN (xxmm from flange). Axial load: xxkg.			
Optional brake (-D5 or D6 option)	Controlled automatic or from input. xxNm, turn on time: 50ms, turn off time: 15ms			
Leakage current to earth	Less than 3 mA @ 50 Hz			
Standards	CE approved / UL recognized -Pending (file number E254947)			
Protection	IP55 (-D2 or D5 version). IP66 (D3 or D6 version)			
Usage / Storage Temperature	Ambient 0 to +40°C (32-104°F)/ Storage (power not applied): -20 to +85°C. (-4 to 185°F) (Humidity 90%). Temperature warning is given before reaching max. Temperature shut down and error message generated at 84°C (183F).			

# 5.1

# Technical Data

Only MAC3000

General		All data are specified for the MAC motor only, i.e. without any expansion module mounted.		
Technology	AC-servomotor (brushless) with built-in 2048 PPR encoder, hall sensors and 3 phase servo amplifier/controller			
Controller capacity		-	MAC3000-D2 or D3	MAC3000-D5 or D6 (w. brake)
	Rated output @3000 RPM	-	3000W	3000W
	Rated Torque RMS / Peak Torque	-	9.55Nm / 28.7Nm	9.55Nm / 28.7Nm
	Inertia (kgcm <sup>2</sup> )	-	27.83 kgcm <sup>2</sup>	27.98 kgcm <sup>2</sup>
	Maximum angular acceleration	-	(TBD) rad/sec <sup>2</sup>	(TBD) rad/sec <sup>2</sup>
	Length	-	312mm / 12.276"	366mm / 14.439"
	Weight (without expansion module)	-	13.2kg	17.1kg
	Audible noise level (measured in 30cm distance)	-	-	65 dB(A)
	Backlash (when brake is activated)	-	-	±0.5 degree
Speed range	0-3000RPM with full torque. Max 3500 RPM. Overspeed protection if speed >3600 = Motor will go in passive mode			
Amplifier control system	Sinusoidal wave PWM control. 5kHz switching			
Filter	6.th. order filter with only one inertia load factor parameter to be adjusted. Expert tuning also available for professionals.			
Feedback	Incremental A and B encoder 8192 CPR. (Physical 2048 PPR/lines per rev.). Optional multiturn absolute encoder.			
Input power supply	3 phase supply 400 to 480AC for driver circuit. Absolute max 550VAC !. 18-32VDC for control circuit. Control circuitry consumption: MAC3000-D1, 2 and 3 (wo/brake) =0.3A @ 24VDC(8W). Control circuitry consumption: MAC3000-D4, 5 and 6 (w/brake) =1.2A @ 24VDC(24W).			
Control modes	<ul style="list-style-type: none"> <li>* ±10V Speed and Torque. A+B encoder outputs</li> <li>* Pulse/direction and 90° phase shifted A++B (Incremental)</li> <li>* RS422 or RS232 (5V) position and parameter commands</li> <li>* Gear mode with analogue input speed offset + different options</li> <li>* Sensor Zero search or mechanical Zero search</li> </ul>			
Flange and shaft dimension	Front: 130x130mm. Rear: 130x203mm(excl. connectors). Shaft Ø24.0mm +0/-0.013mm			
<b>POSITION</b> (pulse inputs)				
Command input pulse	Pulse/direction or 90° phase shifted A+B. RS422			
Input frequency	0-8 MHz. 0-1 MHz with input filter			
Electronic gear	A/B: A= -10000 to 10000, B=1 to10000. Simulation of all step resolutions.			
Follow error register	32 bit			
In position width	0-32767 pulses			
Position range	32 bit. Infinity, Flip over at ±2 <sup>31</sup> pulses.			
<b>POSITION</b> (serial communication)				
Communication facility	From PLC, PC etc via RS422 or asynchronous serial port RS232 with special cable. MacTalk JVL commands, special commands with high security.			
Communication Baud-rate	19200 bit/sec. (19.2kbaud)			
Position range	±67 000 000			
Speed range	0-3000 RPM.			
Digital resolution	0.3606 RPM			
Acceleration range	250 - 444.675 RPM/sec			
Addressing	Point to point on RS422. Up to 32 units on the same serial RS232/RS485 interface with built-in expansion module. Address range 1-254			
Number of parameters.	Standard 85. With MacRegIO software 156 (Only for experts)			
Speed variance	Max ±4 RPM variance between command and actual speed.			
<b>SPEED/ TORQUE</b>				
Analogue speed/torque input.	11bit + sign. Nom. input voltage ±10V. 10kOhm input resistance. Voltage range max. -10 to +32VDC. Offset typical ±50mV.			
Sampling rate at analogue input	750 Hz			
Encoder output signals	A+, A-, B+, B-, RS422. Line driver Typical 1.1 - 3.7 Volt outputs (Driver: SN75176). 90° Phase shifted.			
Analogue speed input	+voltage -> CW rotation. Shaft view			
Zero speed determination.	0 - rated speed.			
Speed variance at rated speed	Initial error @20°C: ±0.0%	Power Supply: ±10%: 0.0%		
	Load 0-300%: ±0.0%	Ambient temperature 0-40°C: ±0.0005% (±50ppm)		
Torque limit in speed mode	0-300% by parameter			
Analogue torque input	+voltage (positive torque) -> CW rotation. Shaft view			
Torque control accuracy	±10% @ 20°C (Reproducibility)			
<b>VARIOUS</b>				
Electromechanical brake	Optional feature. The brake is activated automatically when an unrecoverable error situation occur.			
Regenerative	Integrated power dump. External attachment is possible			
Protective functions.	Error trace back. Overload (I <sup>2</sup> T), Regenerative overload, follow error, function error, regenerative overload (over voltage), software position limit. Abnormality in flash memory, under voltage, over current, temperature too high.			
LED functions	Power (Green LED), Error (Red LED). Note that the LED's are only visible when no module is mounted.			
Output signals	3 general purpose NPN 30V/25 mA outputs. Error and In position.			
Zero search	1: Automatic Zero search with sensor connected to input (2 formats) 2: Mechanical Zero search without sensor. (Torque controlled)			
Shaft load maximum	Radial load: xxN (xxmm from flange). Axial load: xxkg.			
Optional brake (-D5 or D6 option)	Controlled automatic or from input. Brake torque: 16Nm, turn on time: 16ms, turn off time (motor released): 55ms			
Leakage current to earth	Less than 3 mA @ 50 Hz			
Standards	CE approved / UL recognized -Pending (file number E254947)			
Protection	IP55 (-D2 or D5 version). IP66 (D3 or D6 version)			
Usage / Storage Temperature	Ambient 0 to +40°C (32-104°F) Storage (power not applied): -20 to +85°C. (-4 to 185°F) (Humidity 90%). Temperature warning is given before reaching max. Temperature shut down and error message generated at 84°C (183F).			

# 5.2

# Torque Curves

Only MAC050 to 141

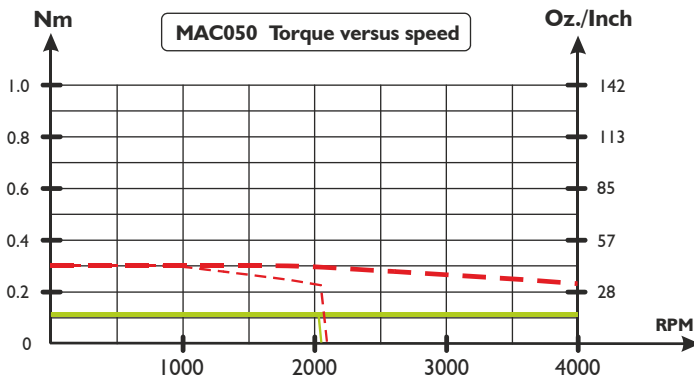

Conditions:  
 Supply voltage = 24 or 48VDC  
 Ambient temperature = 20°C  
 Torque setting = 100%  
 Load setting = 1.0

Operation above 4000 RPM can be done, but the losses in the motor make it impossible to operate in this area cyclicly. Please note that 2700 RPM is the maximum recommended speed for the MAC141.

- = Peak Torque @48V
- = Average Torque @48V
- = Peak Torque @24V
- = Average Torque @24V

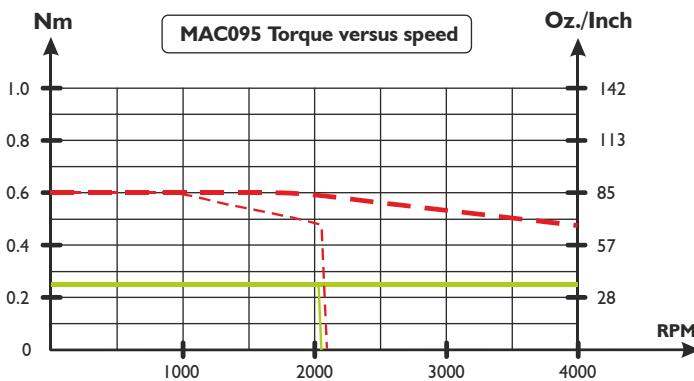

### Speed versus supply voltage



Operation below 12V is not recommended. See also power supply chapter.

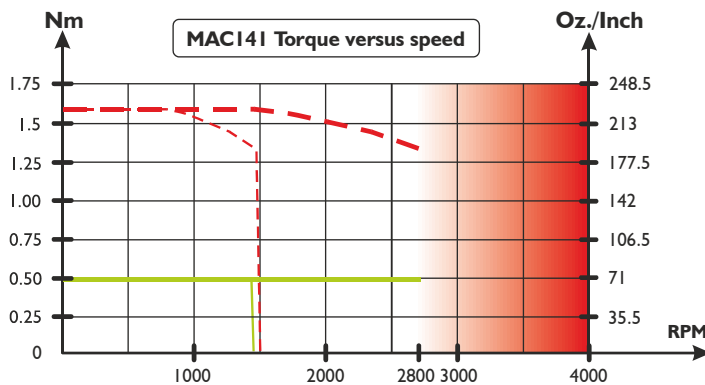
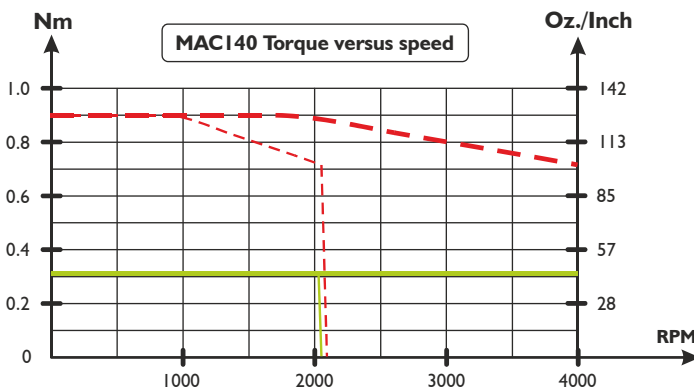

TT0911GB

## 5.2

# Torque Curves

Only MAC400/800

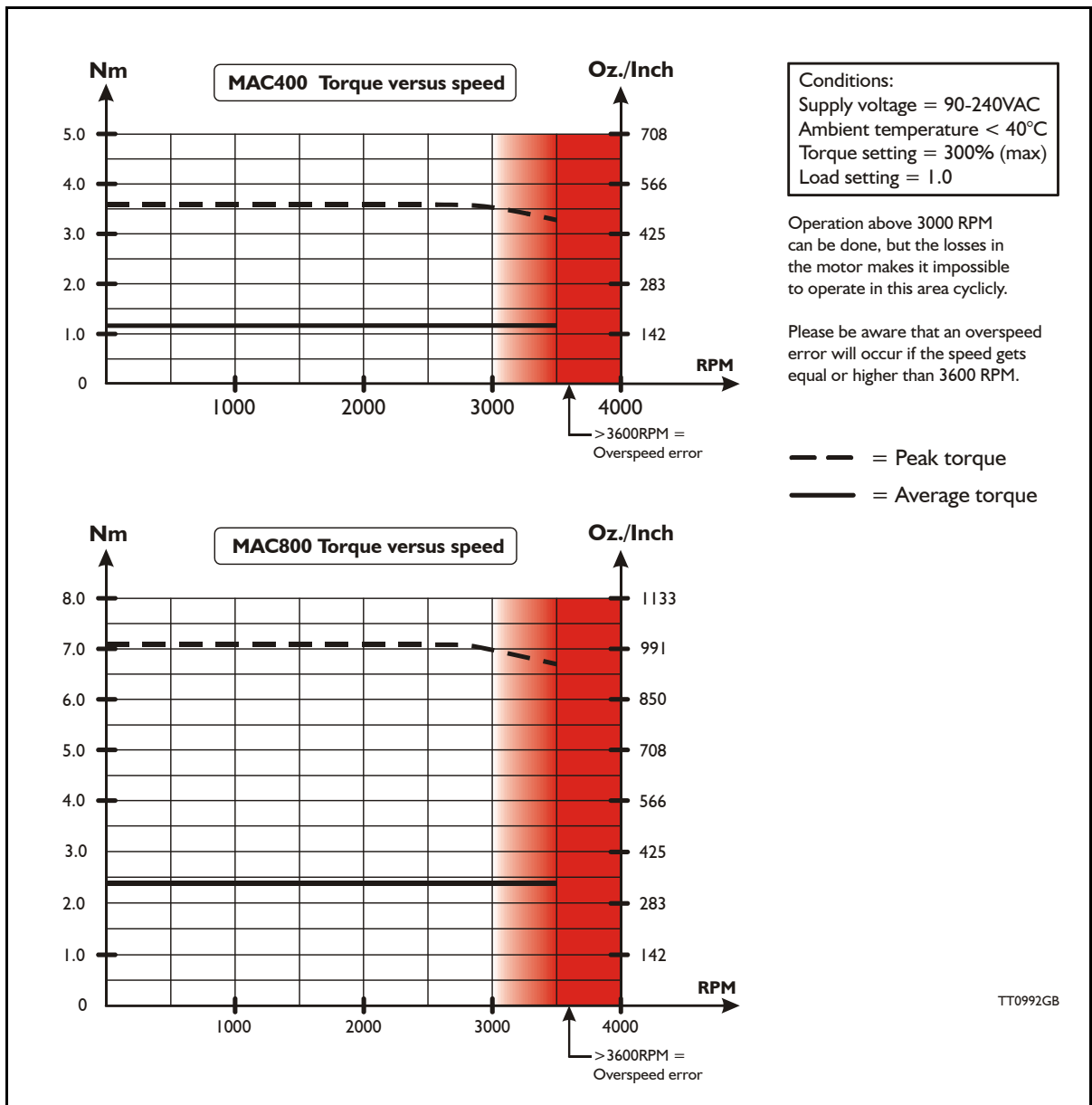

# 5.2

# Torque Curves

Only MAC402

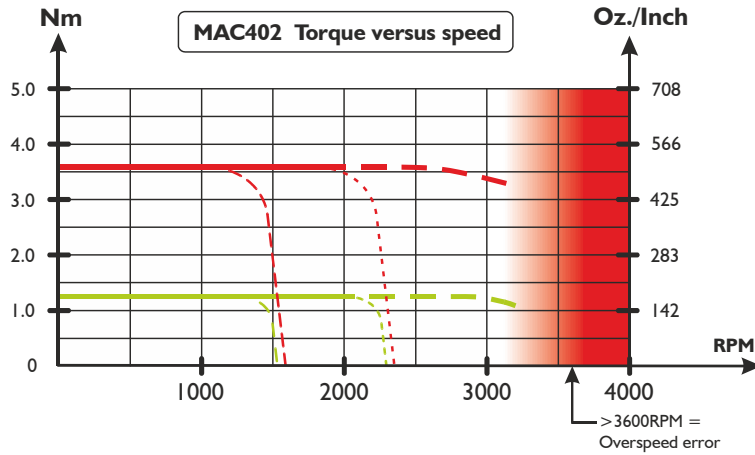

Conditions:  
 Supply voltage = 12-48VDC  
 Ambient temperature < 40°C  
 Torque setting = 300% (max)  
 Load setting = 1.0

Operation above 3000 RPM can be done, but the losses in the motor makes it impossible to operate in this area cyclicly.

Please be aware that an overspeed error will occur if the speed gets equal or higher than 3600 RPM.

- - - = Peak Torque @12V
- - - = Peak Torque @18V
- - - = Peak Torque @24 to 48V
- - - = Average Torque @12V
- - - = Average Torque @18V
- - - = Average Torque @24 to 48V

### Speed versus supply voltage

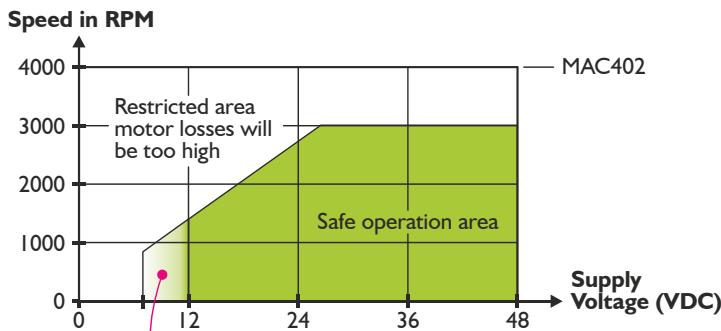

Operation below 12V is possible but at lower speed.  
 The motor shuts down at <8VDC

TT1531-01GB

## 5.3

# Efficiency curve

Only MAC050 to 141

### 5.3.1 Motor efficiency curve

The curve below shows the efficiency of the MAC140 motor as a function of speed. The efficiency is based on the difference in the total amount of electrical power applied to the motor compared with the mechanical output power on the shaft.

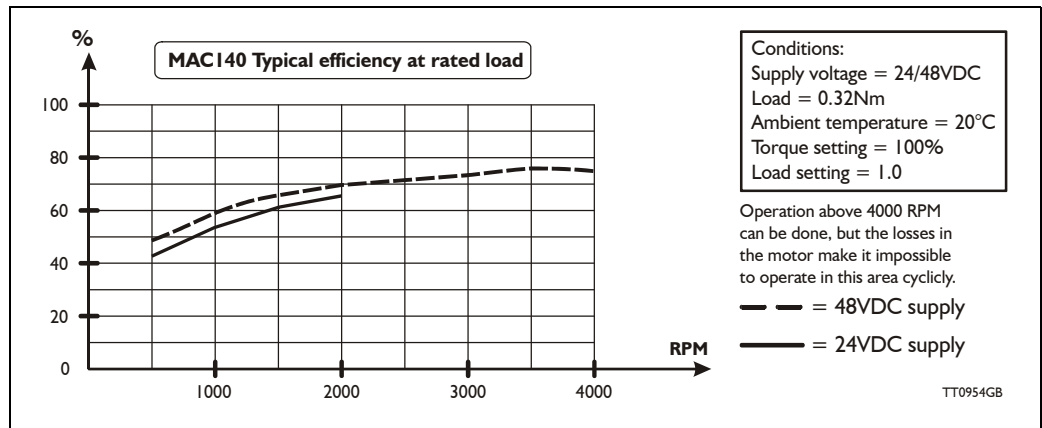

The power consumption for the internal circuitry (microprocessor etc.) is typically < 3.5W. In the speed range from 0 to 500 RPM this internal power consumption starts to be a dominant part of total power consumption which explains that the efficiency is lower.

# 5.4

# Physical Dimensions

Only MAC050 to 141

## 5.4.1 Physical dimensions MAC050 to MAC141

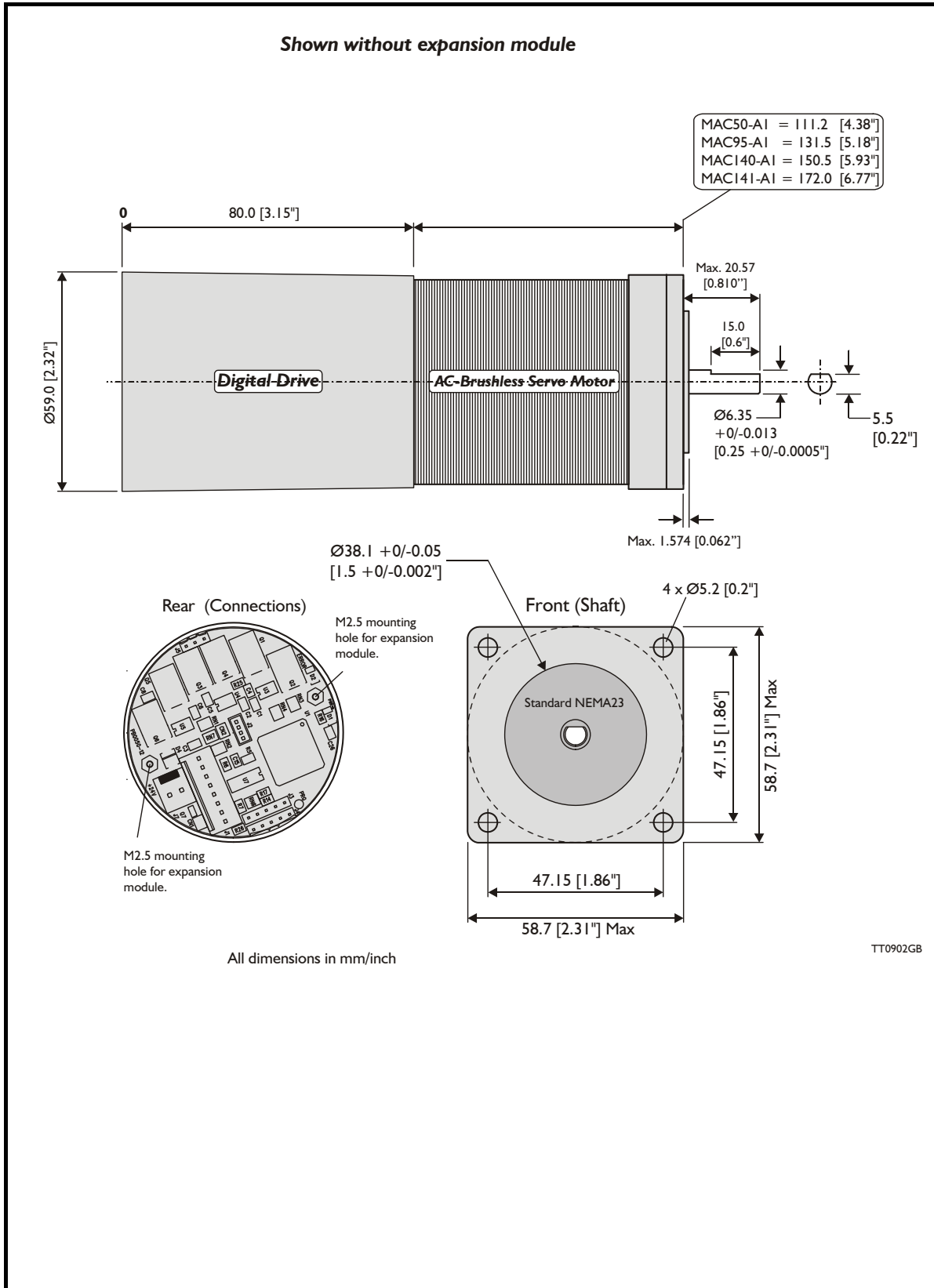

Download CAD drawings from [www.jvl.dk/default.asp?Action=Details&Item=426](http://www.jvl.dk/default.asp?Action=Details&Item=426)

# 5.4

# Physical Dimensions

Only MAC400

## 5.4.2 Physical dimensions MAC400

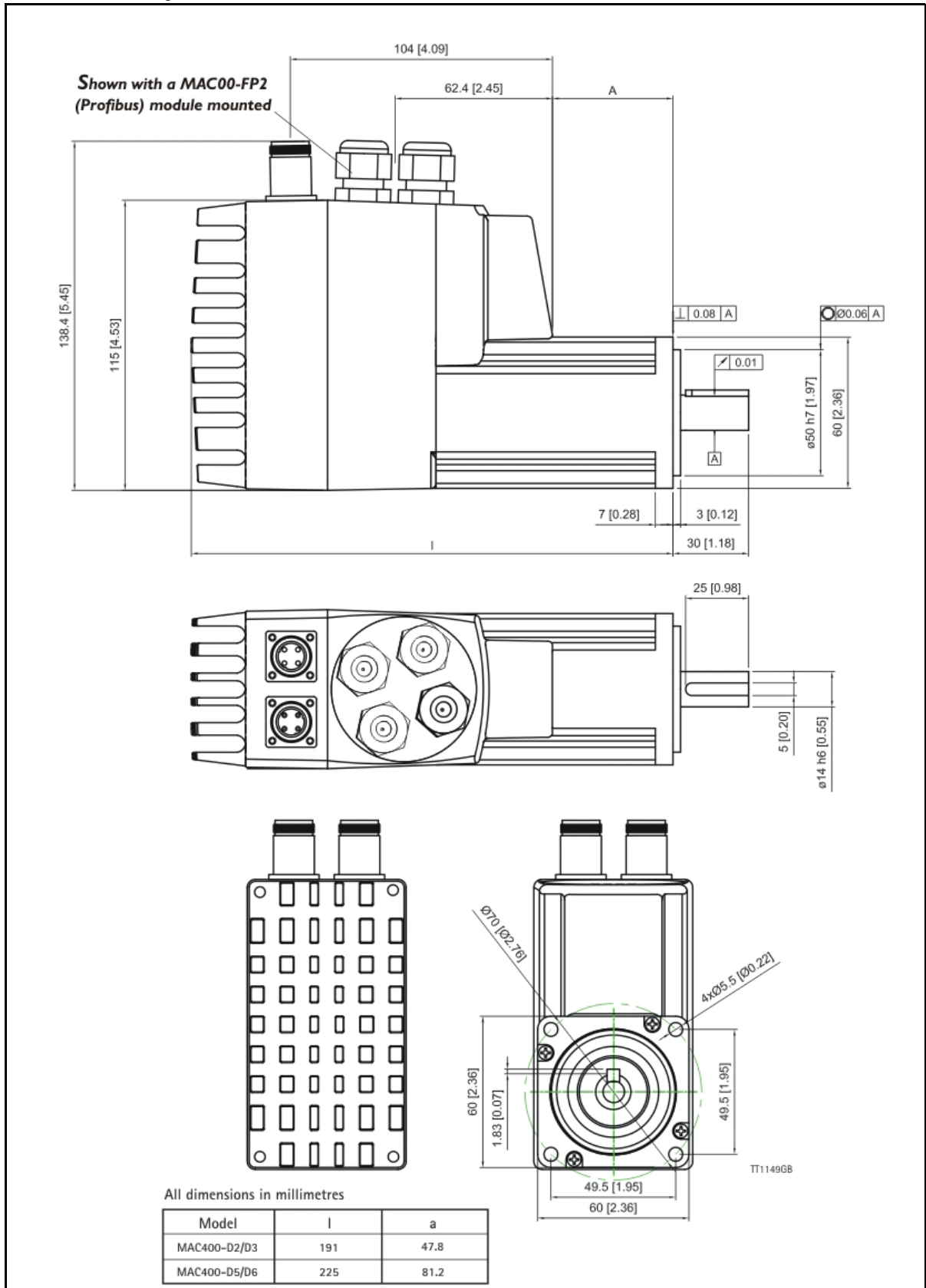

Download CAD drawings from [www.jvl.dk/default.asp?Action=Details&Item=426](http://www.jvl.dk/default.asp?Action=Details&Item=426)



# 5.4

# Physical Dimensions

Only MAC800

## 5.4.3 Physical dimensions MAC800

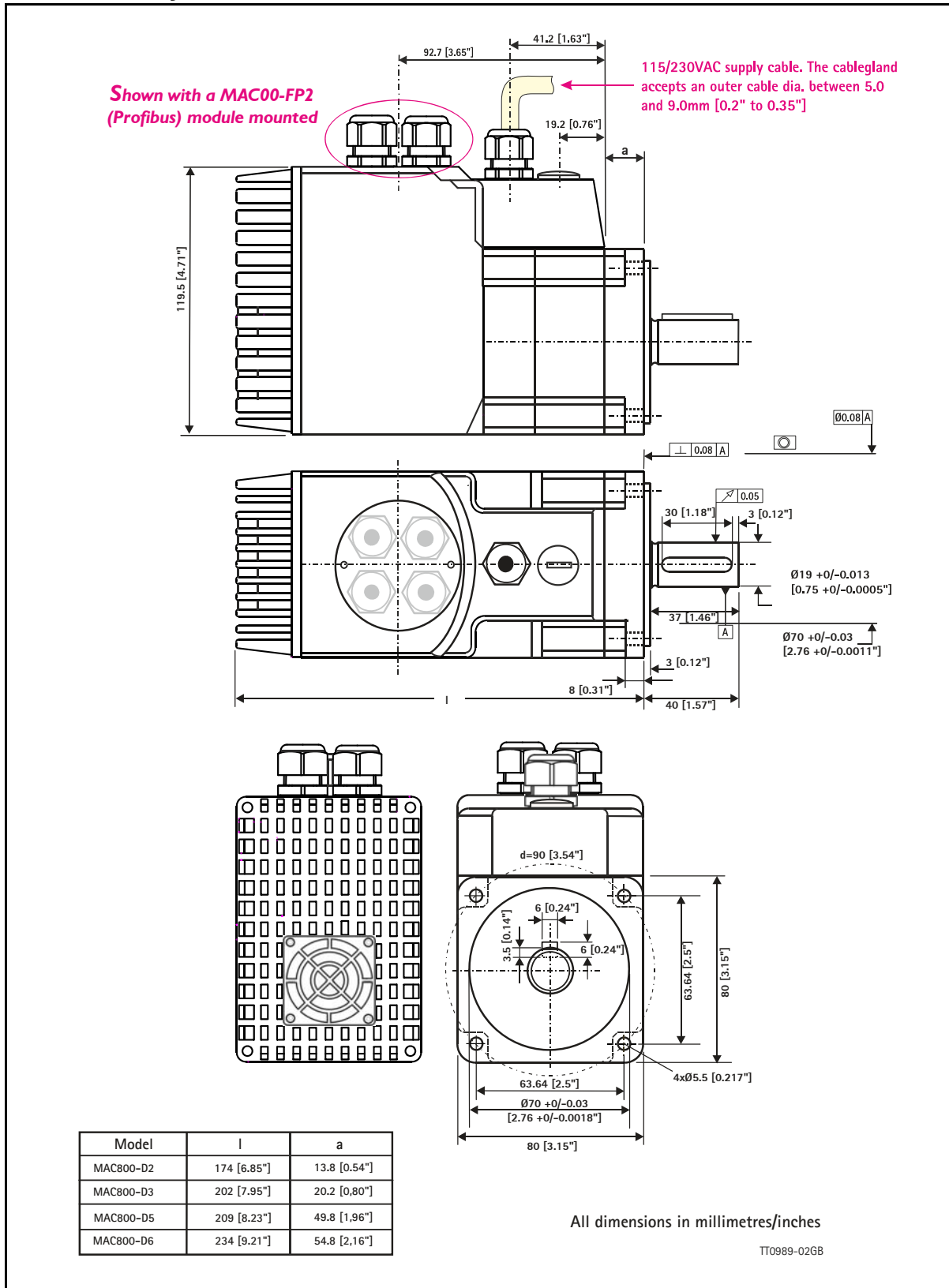

Download CAD drawings from [www.jvl.dk/default.asp?Action=Details&Item=426](http://www.jvl.dk/default.asp?Action=Details&Item=426)

## 5.4

## Physical Dimensions

Only MAC1500

### 5.4.4 Physical dimensions MAC1500-D1

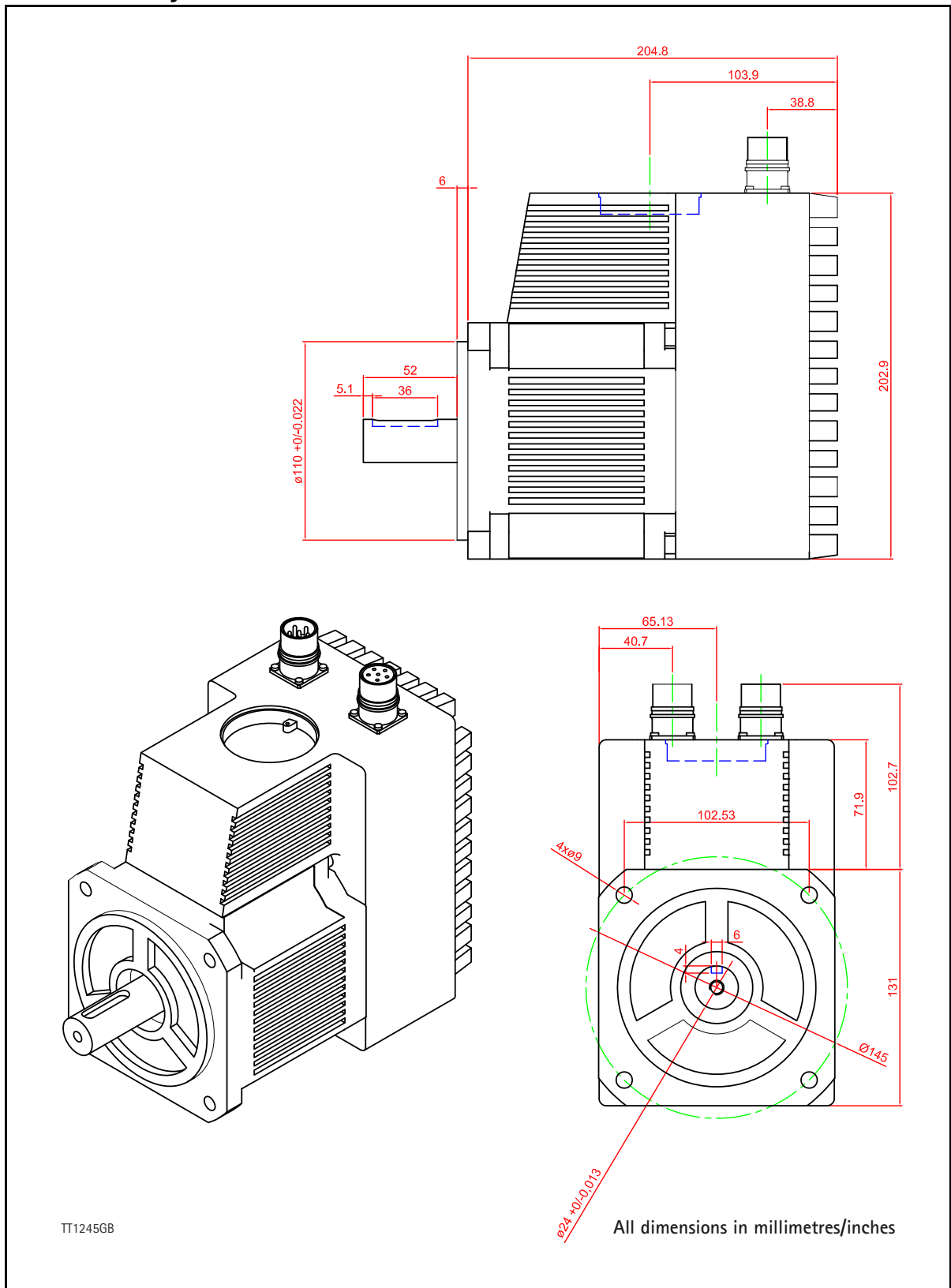

Download CAD drawings from [www.jvl.dk/default.asp?Action=Details&Item=426](http://www.jvl.dk/default.asp?Action=Details&Item=426)

# 5.4

# Physical Dimensions

Only MAC1500

## 5.4.5 Physical dimensions MAC1500-D2 & -D3

Scale		1:1	
Drawing No.		A1	
Customer No.	MAC1500-D2 AC Servo	Product	motor with integrated driver
SKU	19-03-14	Power	1500 W 4.5 Nm
Drawing No.		LT0216-12GB	

**Dimensions:**

- Top View: 235.08 [9.256] (width), 204.53 [8.052] (depth)
- Front View: 250 [9.843] (height), 128.61 [5.063] (width), 90.7 [3.571] (base height)
- Side View: 121.4 [4.724] (height), 58 [2.283] (top section height), 5 [0.197] (flange thickness)
- Bottom View: 134 +0.5/-0.2 [5.278 +0.02/-0.00079] (width), 132 [5.2] (depth)
- Motor Details:
  - Shaft diameter:  $\phi 110 \pm 0.022$  [4.331  $\pm 0.000866$ ]
  - Shaft length: 26.4 [1.039]
  - Flange diameter: 48 [1.891]
  - Flange thickness: 5 [0.197]
  - Terminal block height: 60 [2.362]
  - Terminal block width: 8.0 [0.315]
  - Terminal block offset: 24 [0.945]
  - Terminal block hole diameter:  $\phi 110 \pm 0.022$  [4.331  $\pm 0.000866$ ]
  - Terminal block hole offset: 26.4 [1.039]
  - Terminal block hole diameter:  $\phi 10 \pm 0.02$  [0.394]
  - Terminal block hole offset: 48 [1.891]
  - Terminal block hole diameter:  $\phi 10 \pm 0.02$  [0.394]
  - Terminal block hole offset: 60 [2.362]
  - Terminal block hole diameter:  $\phi 10 \pm 0.02$  [0.394]
  - Terminal block hole offset: 48 [1.891]
  - Terminal block hole diameter:  $\phi 10 \pm 0.02$  [0.394]
  - Terminal block hole offset: 60 [2.362]

Scale: 1:2

TT1538-01GB

Download CAD drawings from [www.jvl.dk/default.asp?Action=Details&Item=426](http://www.jvl.dk/default.asp?Action=Details&Item=426)

# 5.4

# Physical Dimensions

Only MAC1500

## 5.4.6 Physical dimensions MAC1500-D5 & -D6 (with brake)

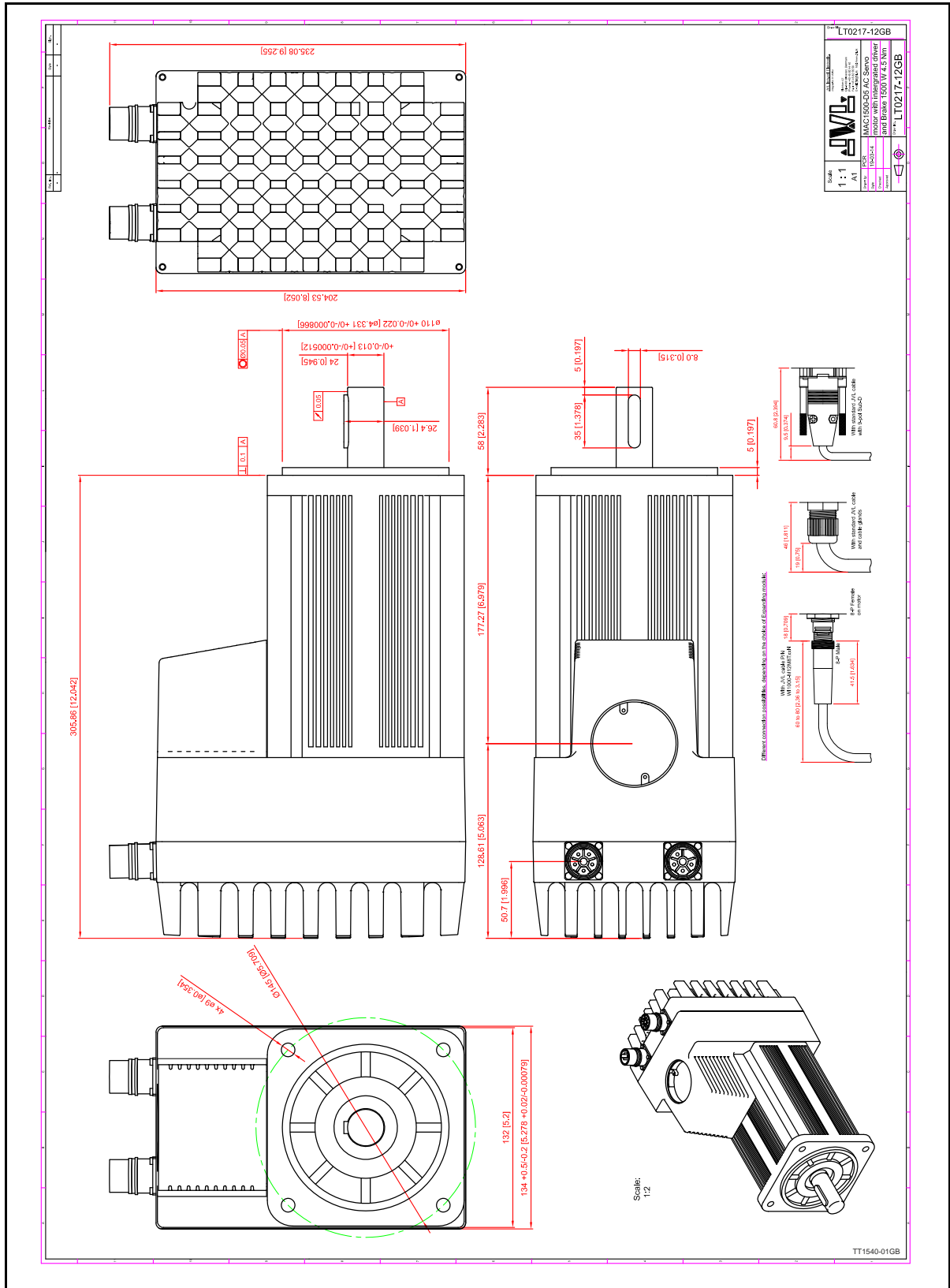

Download CAD drawings from [www.jvl.dk/default.asp?Action=Details&Item=426](http://www.jvl.dk/default.asp?Action=Details&Item=426)

# 5.4

# Physical Dimensions

Only MAC3000

## 5.4.7 Physical dimensions MAC3000-D1

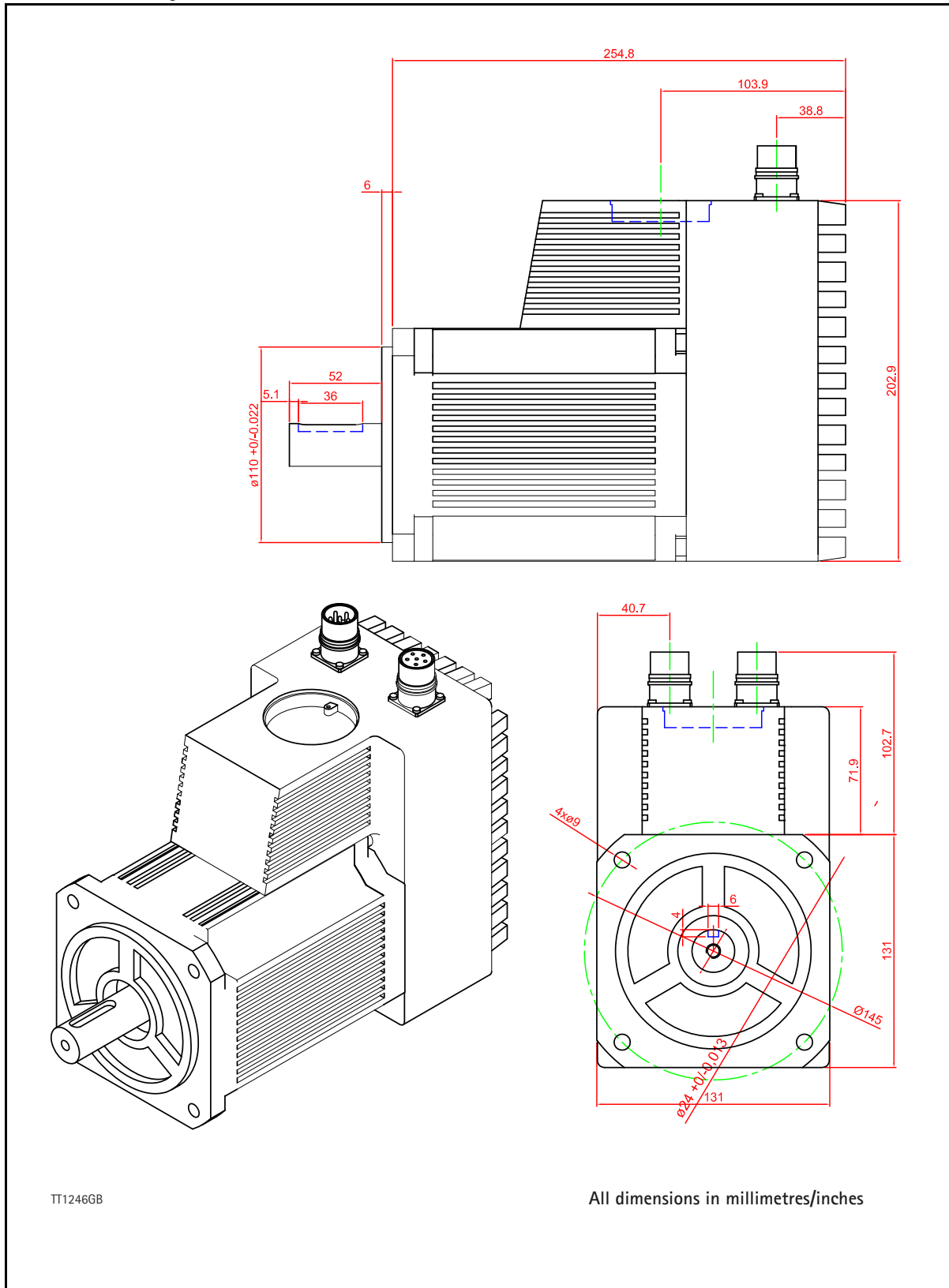

Download CAD drawings from [www.jvl.dk/default.asp?Action=Details&Item=426](http://www.jvl.dk/default.asp?Action=Details&Item=426)

# 5.4

# Physical Dimensions

Only MAC3000

## 5.4.8 Physical dimensions MAC3000-D2 & -D3

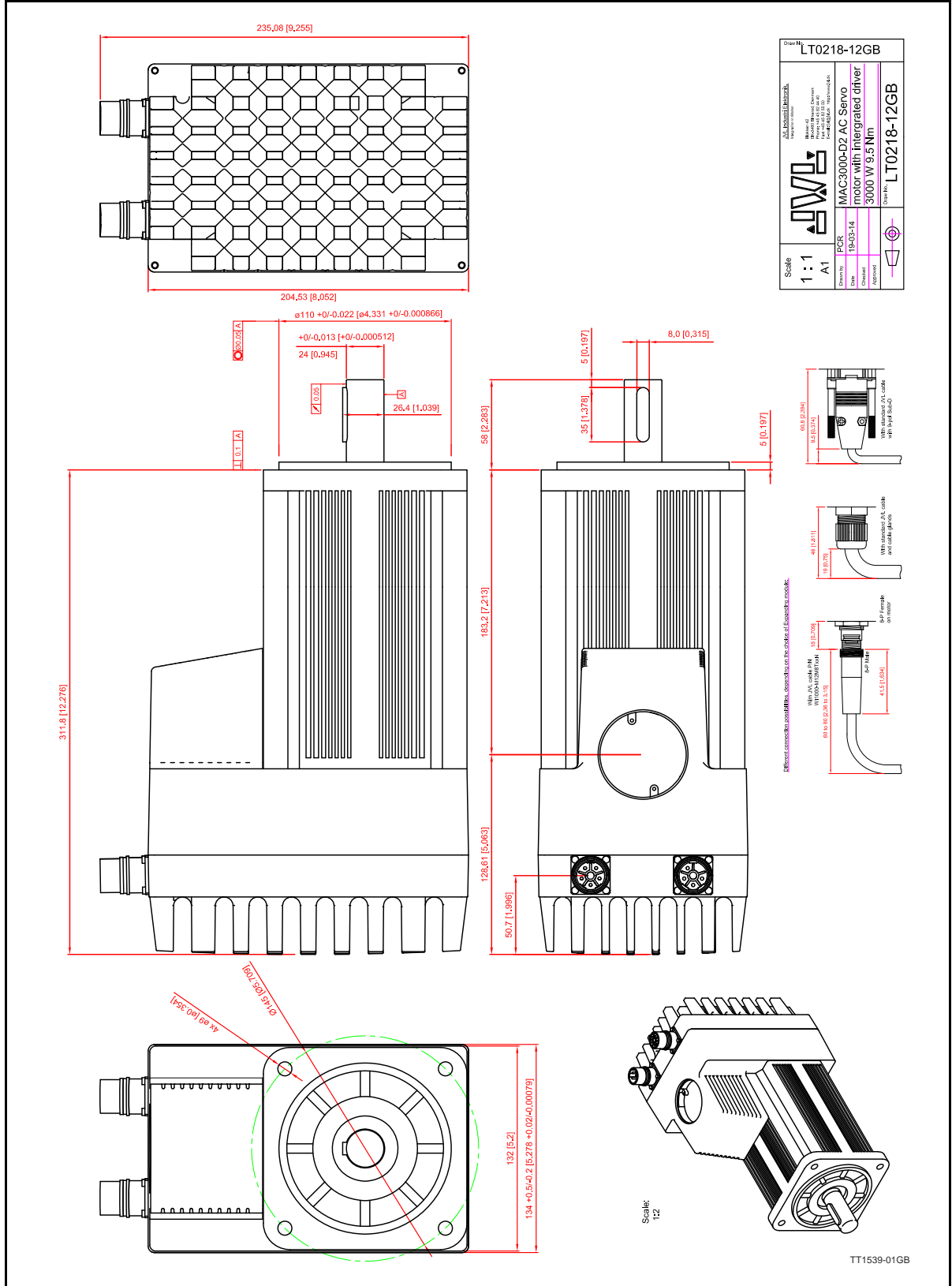

Download CAD drawings from [www.jvl.dk/default.asp?Action=Details&Item=426](http://www.jvl.dk/default.asp?Action=Details&Item=426)

# 5.4

# Physical Dimensions

Only MAC3000

## 5.4.9 Physical dimensions MAC3000-D5 & -D6

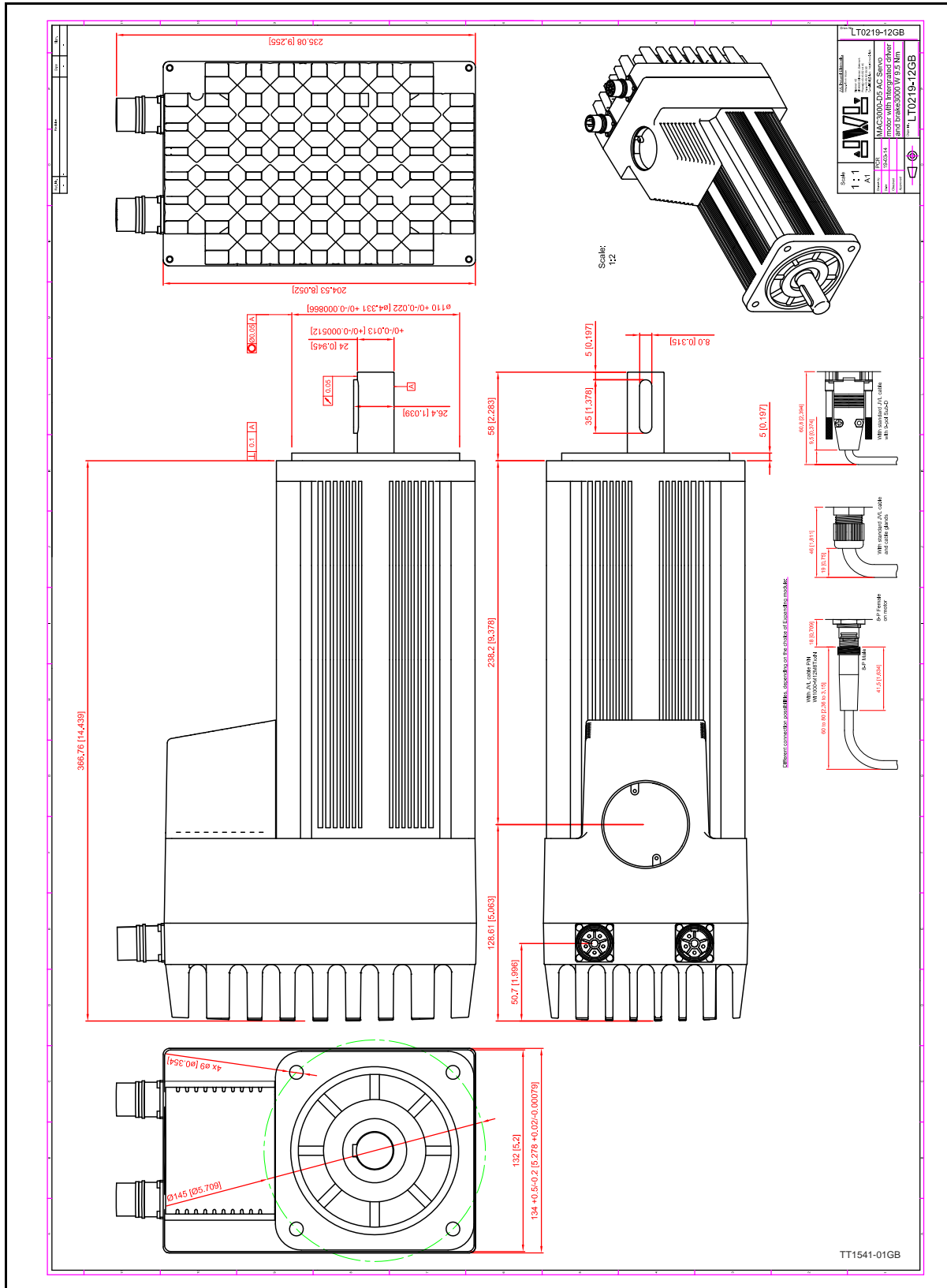

## 5.5.1 Life time of ball bearings in MAC141

The curve below can be used to determine the relation between the radial load at the motor output shaft and where the load is placed at the shaft with reference to the flange of the motor.

The curves are based on a continuous speed of 3000 RPM.

If the speed is lowered the lifetime will increase inversly proportional.

### Example:

A motor is having a radial load of 200N placed with center 10 mm from the flange.

According to the curve the lifetime will be 19000 hours at 3000 RPM.

If the speed is lowered to 300 RPM (10 times lower than the curve is specified at) the lifetime will increase 10 times giving a total of 190000 hours of operation.

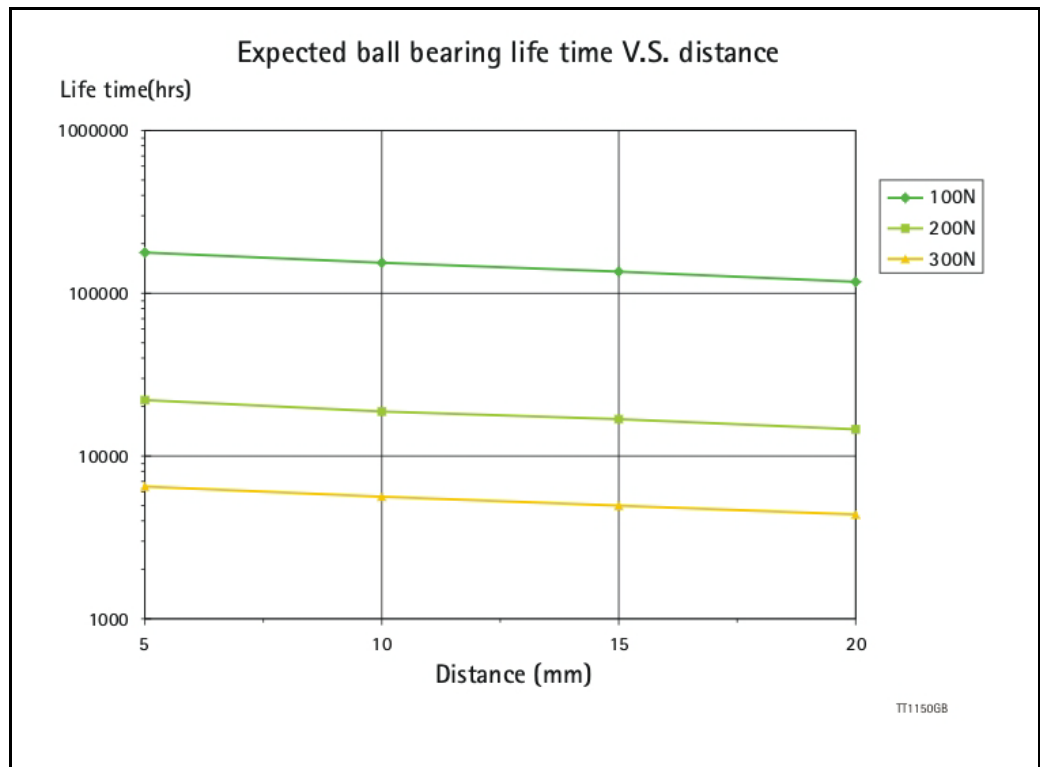



5.5.2 Life time of ball bearing in MAC400

The curve below can be used to determine the relation between the radial load at the motor output shaft and where the load is placed at the shaft with reference to the flange of the motor.

The curves are based on a continuous speed of 3000 RPM.

If the speed is lowered the lifetime will increase inversly proportional.

**Example:**

A motor is having a radial load of 200N placed with center 15 mm from the flange.

According to the curve the lifetime will be 102000 hours at 3000 RPM.

If the speed is lowered to 300 RPM (10 times lower than the curve is specified at) the lifetime will increase 10 times giving a total of 1020000 hours of operation.

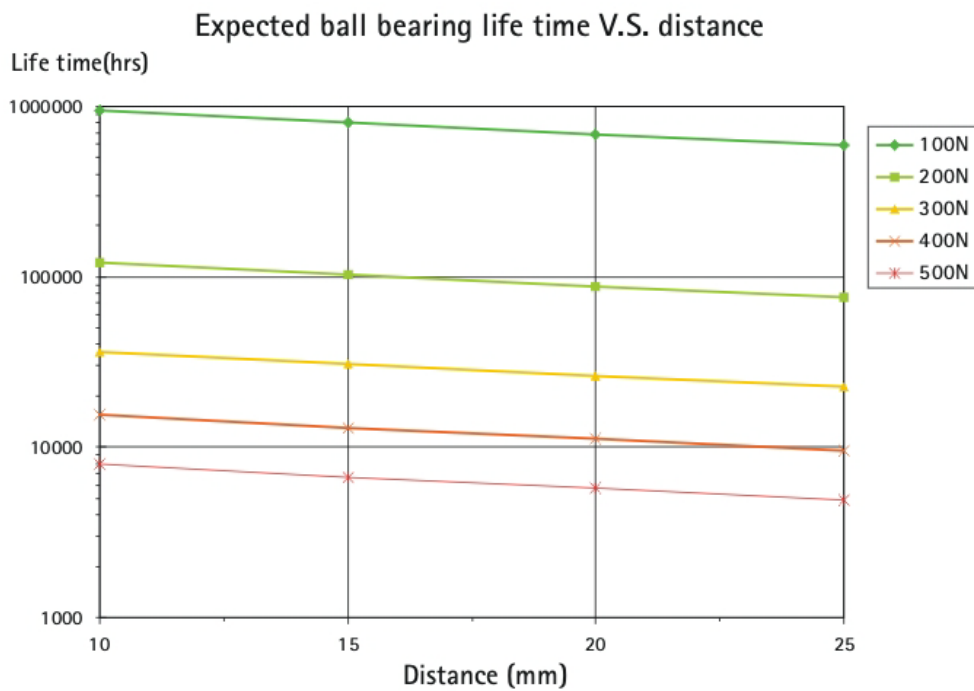

TT1148GB

## 5.5.3 Life time of ball bearing in MAC800

The curve below can be used to determine the relation between the radial load at the motor output shaft and where the load is placed at the shaft with reference to the flange of the motor.

The curves are based on a continuous speed of 3000 RPM.

If the speed is lowered the lifetime will increase inversly proportional.

### Example:

A motor is having a radial load of 200N placed with center 20 mm from the flange.

According to the curve the lifetime will be 68000 hours at 3000 RPM.

If the speed is lowered to 300 RPM (10 times lower than the curve is specified at) the lifetime will increase 10 times giving a total of 680000 hours of operation.

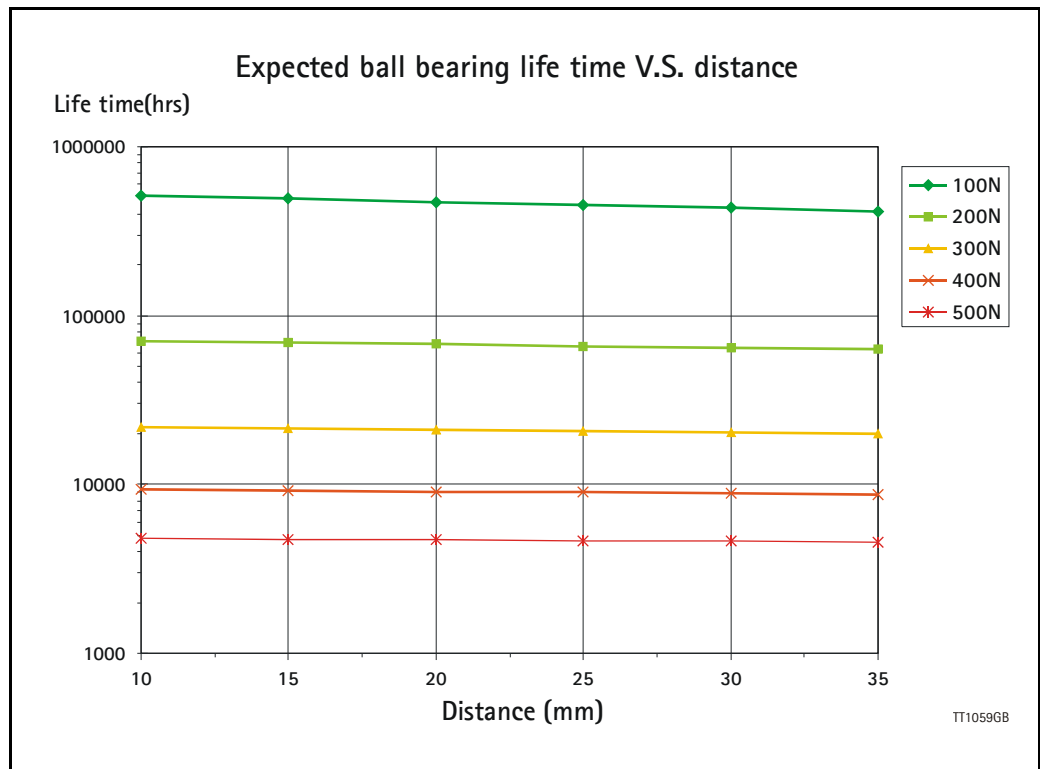

## 5.6

# Installation instructions

### 5.6.1 Mounting a gear or a brake at the motor

When a gear or a brake is to be mounted on the front end of a motor it is very important that this is done in the right way since a wrong way of mounting may have fatal influence at lifetime of the motor or gear/brake and performance.

Please follow this instruction step by step to make sure that the mounting is done with a good result.

- 1** Step 1 - Make sure that the shaft collar is oriented correctly in order to assure that the right tension around the motor shaft is possible.  
Hint: Tighten the shaft collar gently just to keep it in the right position.

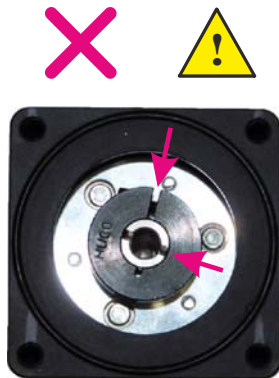

The inner and outer slit is NOT aligned. Make sure they are aligned as shown at right illustration

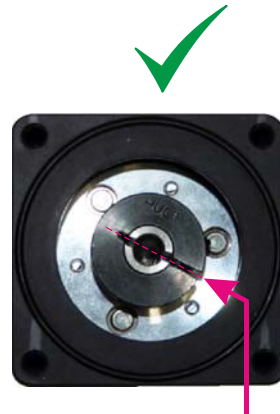

The inner and outer slit is aligned as they should.

- 2** Step 2 - Mount the gear or brake at the motor but make sure to fasten the 4 shaft bolt first before fastening the shaft collar.  
Its recommended to use Loctite 278 in the threads to make sure that the bolts stay in place.

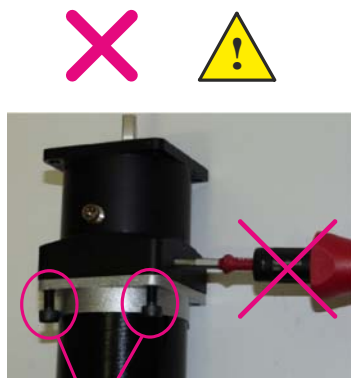

Do NOT tighten the shaft collar before the flange bolts are tightend



Flange bolts properly mounted and tightend.

TT1536-01GB

## 5.6

## Installation instructions

- 3** Step 3 - Final stage. Fasten the shaft collar with a torque of according to the scheme below.

Please notice that it can be fatal not to use the specified torque since the shaft may slip over time and cause a position offset.

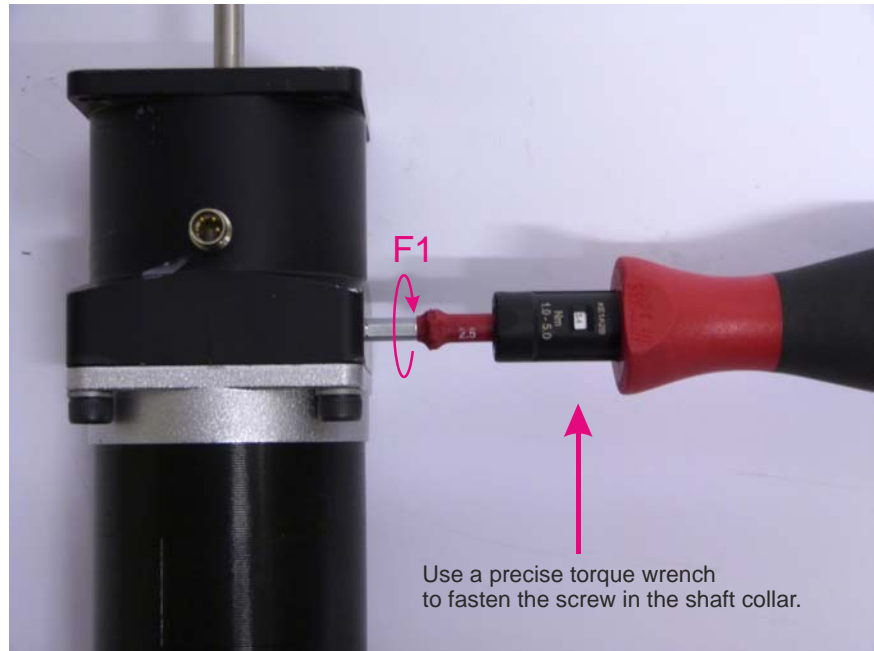

### Gears (Product type to be mounted)

Series	Used with motor type	Tool	Torque (F1)
HTRG05	MAC050 to MAC141 (Ø6.35 shaft)	Hex size 3	5Nm
HTRG05	MIS230-233 (Ø6.35 shaft)	Hex size 3	5Nm
HTRG06	MAC050 to MAC141 (Ø6.35 shaft)	Hex size 3	5Nm
HTRG06	MAC400-402 (Ø14 shaft)	Hex size 3	11Nm
HTRG08	MIS340-341 (Ø9.53 shaft)	Hex size 4	5Nm
HTRG08	MIS342 (Ø14 shaft)	Hex size 5	8Nm
HTRG08	MAC800 (Ø19 shaft)	Hex size 5	11Nm
HTRG10	MAC800 (Ø19 shaft)	Hex size 5	11Nm

### Brakes (Product type to be mounted)

Series	Used with motor type	Tool	Torque (F1)
MAB23x	MAC050 to MAC141 (Ø6.35 shaft)	Hex size 2.5	2Nm
MAB23x	MIS230-233 (Ø6.35 shaft)	Hex size 2.5	2Nm
MAB34x	MIS340-341 (Ø9.53 shaft)	Hex size 3	5Nm
			TT1537-01GB

## 5.6 Installation instructions

---

### 5.6.2 Operation at higher altitudes

Since the air density at higher altitudes is lower it becomes more difficult for the motor to dissipate the heat losses to the surrounding air.

If an installation is done at more than 1000m (3281ft) the output power is derated as shown below in the table.

Height above sea level (m)	=< 1000	1500	2000	2500	3000	3500	4000	4500	5000
Height above sea level (ft)	=< 3281	4921	6562	8202	9843	11483	13123	14764	16404
Power rating %	100	96	92	88	84	80	76	72	68

**Example:**

A MAC400 motor with a nominal power rating of 400W is operating in an altitude of 2500m above sea level.

The power rating at this level is 88% which means that the nominal power is derated to 352W.

Since the heat dissipation in the motor and electronics is primarily influenced by the actual torque it is recommended to lower the torque to keep within the maximum power. The speed can be kept at the nominal value.

## 5.6

# Installation instructions

### 5.6.3 Precautions when installing IPx5/x6/x7 motors

When installing MAC motors with a higher ingress protection (IPx5/x6/x7) a few rules must be respected in order to assure no ingress over time.



**Please notice:**

The MAC products are not covered by the warranty if the following rules/guidance is not fully followed.

#### Rule 1 - Mounting the expansion module (MAC00-xxx)

All the expansion modules are IP67 rated but under the condition that its mounted correctly in the motor so the surface of the module is in same level as the surrounding motor surface.

The 2 pcs. M2.5 hexagon screws in the module must also be tightened with **0.8 to 1.0 Nm**. Use a torque screw driver to make sure the torque is ok.

Also make sure to use protective caps on un-used connectors.

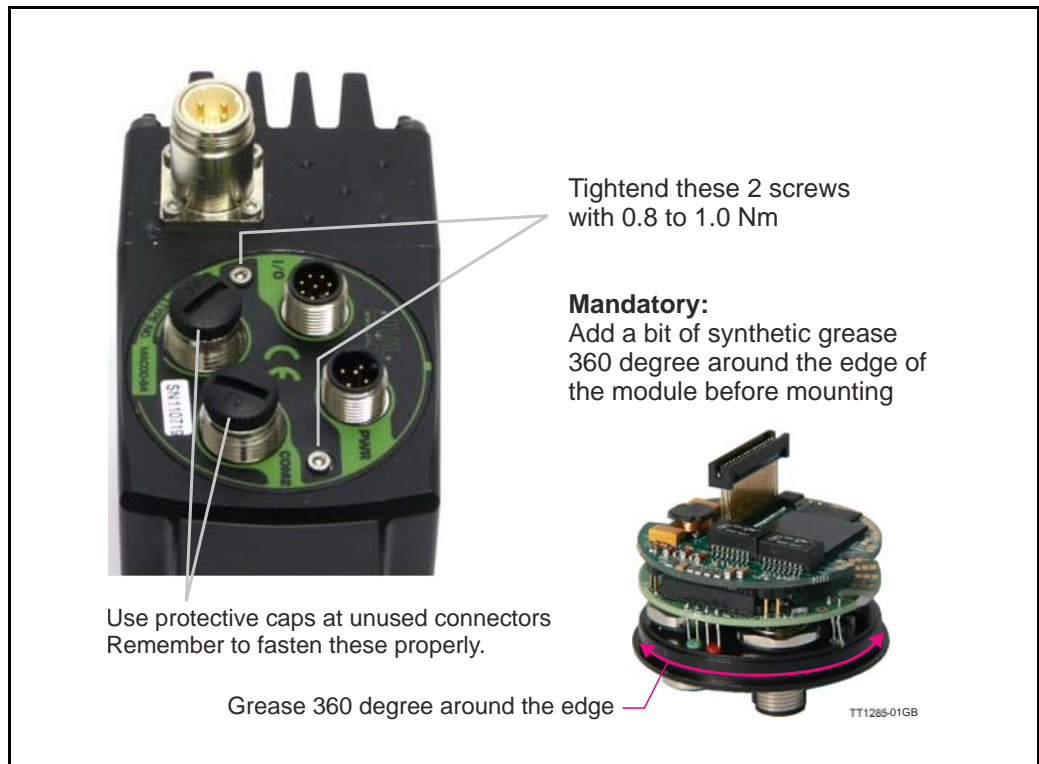

#### Rule 2 - Connectors

Make sure to tighten all connectors with a proper high torque to make sure that no moisture/liquids can find a way inside the connector.

All circular connectors at motors and modules including cables with matching connectors offered by JVL is guaranteed to be IP67 or higher but under the condition that they are tightened with a proper high torque.

Make sure to use protective caps at unused connectors. Also make sure that the protective caps are tightened properly.

## 5.6

## Installation instructions

### Rule 3 - Motor mounting orientation in IPx5/x6/x7 applications

Its not recommended to mount the motor with the expansion module pointing upwards since it will be more exposed to moisture that accumulate at the surface and around the connectors and can leak inside the motor over time.

If the actual application require this mounting orientation please add a shield/cup over the motor to shield the module. Also avoid direct sunlight if mounted outside in open air.

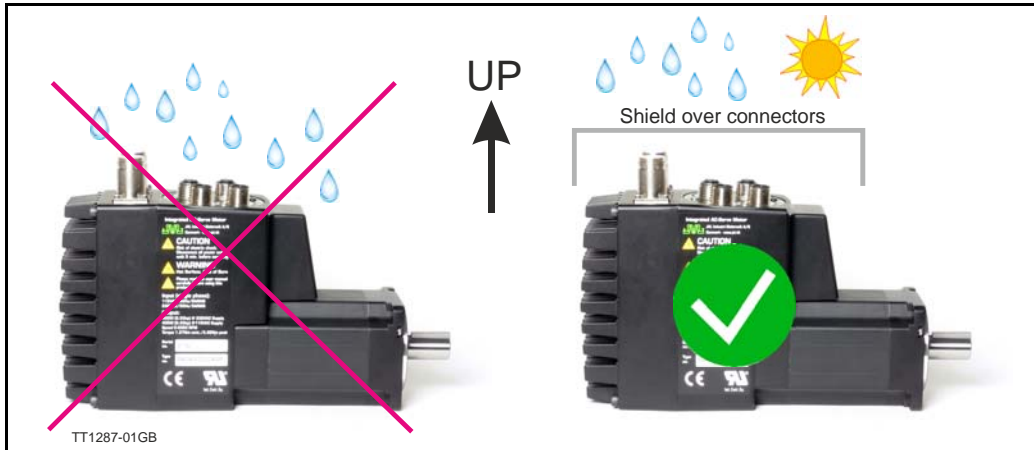

### Rule 4 - Cable placement.

In certain invironments where the temperature changes fast and often it may be a problem that moisture condensate inside the cabinet.

Always consider if condensation of moisture or even liguid can be present in the cabinet or similar where the cables for the MAC motor is drawn from.

If this is considered to be a risk then always make sure that the cable is placed as below with a point higher than the cabinet bottom before it connects to the motor to avoid moisture or liquid to flow inside the cable to the motor connectors.

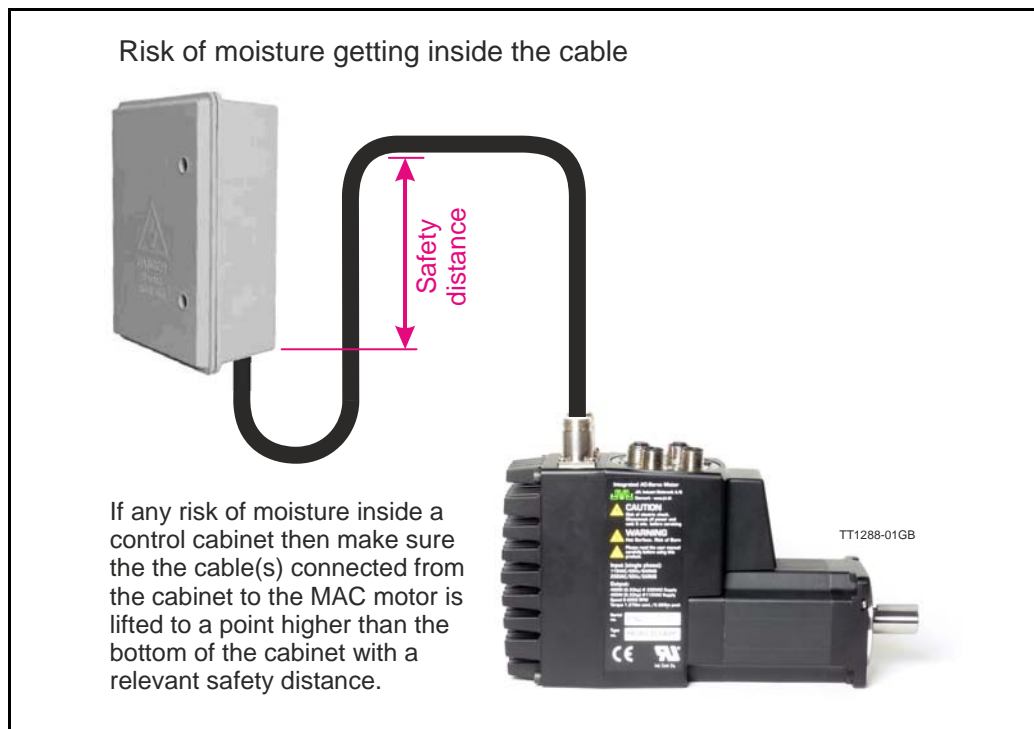

## 5.6

## Installation instructions

### Rule 5 - Precautions concerning MAC800-D3 and -D6.

The MAC800-D3 and MAC800-D6 is offering IP65 protection. To obtain this protection degree it is very important that the various components are mounted and fasten properly according to the illustration below.

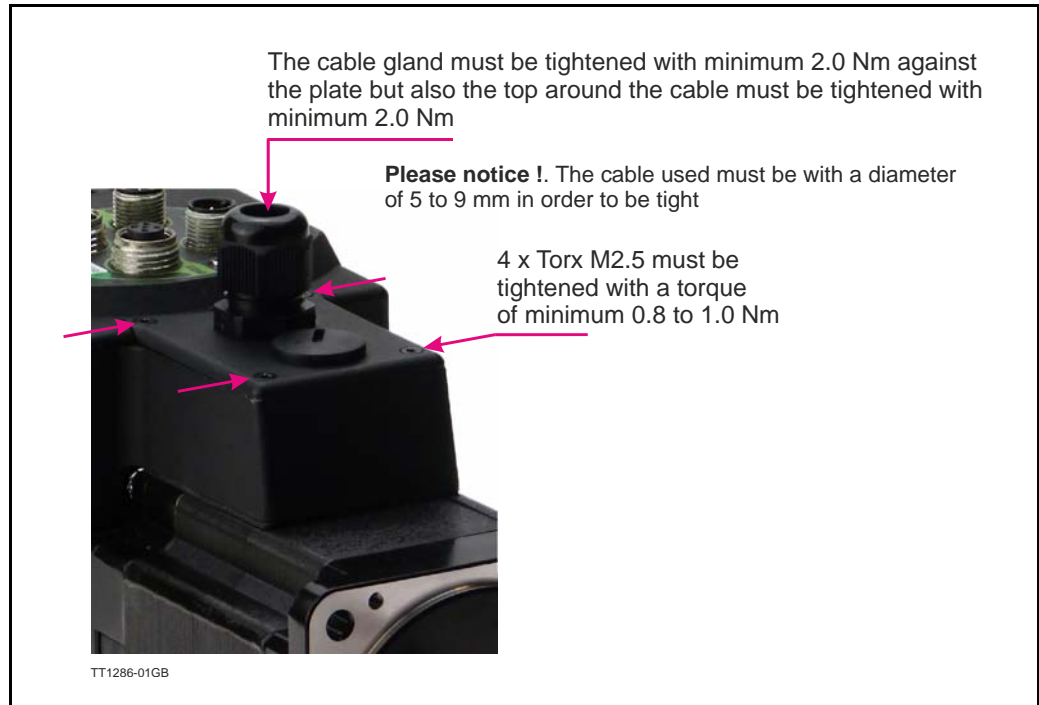



## 5.7 Emergency stop considerations

---

### 5.7.1 Emergency stop

Fundamental considerations regarding the safety of machines:

In the construction of machines there are several basic requirements that a machine manufacturer or producer must fulfil. It is the machine manufacturer's responsibility to ensure that applicable regulations are fulfilled.

The following presents a broad overview of the applicable regulations in Europe (the EEC). If a machine manufacturer markets its products in other countries, it is the manufacturer's responsibility to ensure compliance with local national regulations. It cannot therefore be assumed that a machine that is produced in accordance with European requirements will automatically also comply with regulations that are applicable in other markets, even though these are acknowledged in several countries. The most important European regulation in this context is the Machinery Directive, which in Denmark is implemented via the Danish Working Environment Authority's Executive Order no. 561.

This Executive Order prescribes requirements to ensure that machines are safe, that a technical dossier including a health and safety risk analysis is prepared, and that the machine is supplied together with instructions for use a EC declaration of conformity and furthermore that the machine is CE marked.

The Essential Health and Safety Requirements are specified in the Directive's appendix I. To ensure compliance with these requirements, it is advantageous to use various standards which are described later.

Overall, the most important requirement is to fulfil the Machinery Directive's requirements regarding safety integration, which in brief can be described as follows:

- 1st. priority: the machine's construction must ensure that it is not dangerous.

Example:

The machine construction is such that it is not possible to come into contact with rotating parts of other potentially dangerous components, either during operation, set-up or maintenance.

- 2nd priority: in cases where it is not always possible to achieve a construction that does not present a potential hazard, additional protective measures must be incorporated to eliminate risk.

Example:

No direct access to rotating or other potentially hazardous parts and components is possible without the removal of a screen, guard, protective cover or other means of protection.

- 3rd priority: to the extent where a machine construction and the built-in safety measures still leave some potential risk, clear warnings of hazard must be given using signs on the machine itself, and by information in the operation manual and by training if necessary.

It is the risk evaluation of the machine that determines what is necessary to fulfil the essential health and safety requirements of the Machinery Directive and thus also which protective measures are required.

It is also the risk assessment that determines whether an emergency stop function is required.

## 5.7 Emergency stop considerations

---

An emergency stop is not required only in cases where it is completely evident that an emergency stop would not prevent an injury, minimise an injury or stop an injury. In practice this means that essentially all machines must incorporate an emergency stop function.

It must be emphasised that a machine's emergency stop function is NOT a preventive measure, but is regarded as a supplementary measure. This means that the protective measures that must be implemented as a result of the machine's risk assessment cannot be replaced by an emergency stop function.

The protective measures required must be implemented such that they are reliable, i.e. not themselves prone to error or failure. The extent to which this is required depends on the risk that the actual protective measure is designed to eliminate, i.e. the greater the hazard, the more secure and reliable the protective measure.

Protective measures and the emergency stop function are often implemented using the machine's electrical control system.

For guidelines on how the control system's safety related components can be implemented, related standards can be used.

### 5.7.2 EN 60204-1

DS/EN 60204-1 is applicable for the general requirements of a machine's electrical systems. This standard defines several stop categories, paragraph 9.2.2 Stop functions in DS/EN 60204-1

There are three categories of stop function as follow:

- Stop category 0: stopping by immediate removal of power to the machine actuators (i.e. an uncontrolled stop – paragraph 3.56 in DS/EN 60204-1).
- Stop category 1: a controlled stop (paragraph 3.11 in DS/EN60204-1) with power available to the machine actuators to achieve the stop and then removal of power when the stop is achieved..
- Stop category 2: a controlled stop with power left available to the machine actuators.

Requirements are given that a stop function must be incorporated (paragraph 9.2.5.3 Stop in DS/EN 60204-1)

Stop category 0 and/or category 1 and/or category 2 stop functions shall be provided as indicated by the risk assessment and the functional requirements of the machine (paragraph 4.1 in DS/EN 60204-1).

NOTE: The supply disconnecting device (paragraph 5.3 in DS/EN 60204-1) when operated achieves a stop category 0. Stop functions shall override related start functions (see §9.2.5.2 in DS/EN 60204-1).

Similarly, requirements are specified for the implementation of an emergency stop function:

## 5.7 Emergency stop considerations

---

### Paragraph 9.2.5.4.2 Emergency stop (DS/EN 60204-1)

Principles for the design of emergency stop equipment, including functional aspects, are given in ISO 13850.

The emergency stop shall function either as a category 0 or as a category 1 stop (paragraph 9.2.2 in DS/EN 60204-1). The choice of the stop category of the emergency stop depends on the results of a risk assessment of the machine.

In addition to the requirements for stop functions (paragraph 9.2.5.3 in DS/EN 60204-1), the emergency stop function has the following requirements:

- it shall override all other functions and operations in all modes.
- power to the machine actuators that can cause a hazardous situation(s) shall be either removed immediately (category 0 stop) or shall be controlled in such a way to stop the hazardous motion as quickly as possible (stop category 1) without creating other hazards.
- reset shall not initiate a restart.

Considerations are also given regarding the safety and reliability of control circuits:

### 5.7.3 Paragraph 9.4 Control functions in the event of failure

#### Paragraph 9.4.1 General requirements (DS/EN 60204-1)

Where failures or disturbances in the electrical equipment can cause a hazardous situation or damage to the machine or to the work in progress, appropriate measures shall be taken to minimize the probability of the occurrence of such failure or disturbances. The required measures and the extent to which they are implemented, either individually or in combination, depend on the level of risk associated with the respective application (paragraph 4.1 in DS/EN 60204-1).

The electrical control circuits shall have an appropriate level of safety performance that has been determined from the risk assessment at the machine. The requirements of IEC 62061 and/or ISO 13849-1:1999, ISO 13849-2:2003 shall apply.

Measures to reduce those risks include, but are not limited to:

- Protective devices on the machine (for example. interlocks guards, trip devices),
- Protective interlocking of the electrical circuit,
- use of proven circuit techniques and components (paragraph 9.4.2.1 in DS/EN 60204-1)
- provision of partial or complete redundancy (paragraph 9.4.2.2 in DS/EN 60204-1) or diversity (paragraph 9.4.2.3 in DS/EN 60204-1),
- Provision for functional tests (paragraph 9.4.2.4 in DS/EN 60204-1).

As noted, reference is made to several other standards which describe how safety related parts of the control system can be implemented.

In practice DS/EN 954-1 can be used, although this will be superseded by DS/EN ISO 13849-1 in 2009. The principles of both standards is the same: to first determine the required level of safety and reliability of the control circuits and thereafter design the safety related components of the control system to achieve the required level.

In DS/EN 954-1 the architecture of the safety related circuits is used exclusively as the goal for the level of safety. The standard prescribes 5 categories: B, 1, 2, 3, and 4, where B represents the lowest level and 4 the highest.

## 5.7 Emergency stop considerations

DS/EN ISO 13849-1 utilizes another criterion for safety level called the "Performance level" - PL – in which both the architecture and the component's failure rate are included. 5 PL levels are defined: a, b, c, d, and e, where a represents the lowest level and e the highest.

If DS/EN ISO 13849-1 is used, information regarding the components' failure rates (MTTF – mean time to failure) must be obtained from the component manufacturer.

For a more detailed description of the principles and requirements above, see the relevant standards.

The following drawings illustrates examples of the design of safety circuits for an emergency stop and enclosure system, stop category 0, which fulfils the requirements of category 4 in accordance with DS/EN 954-1.

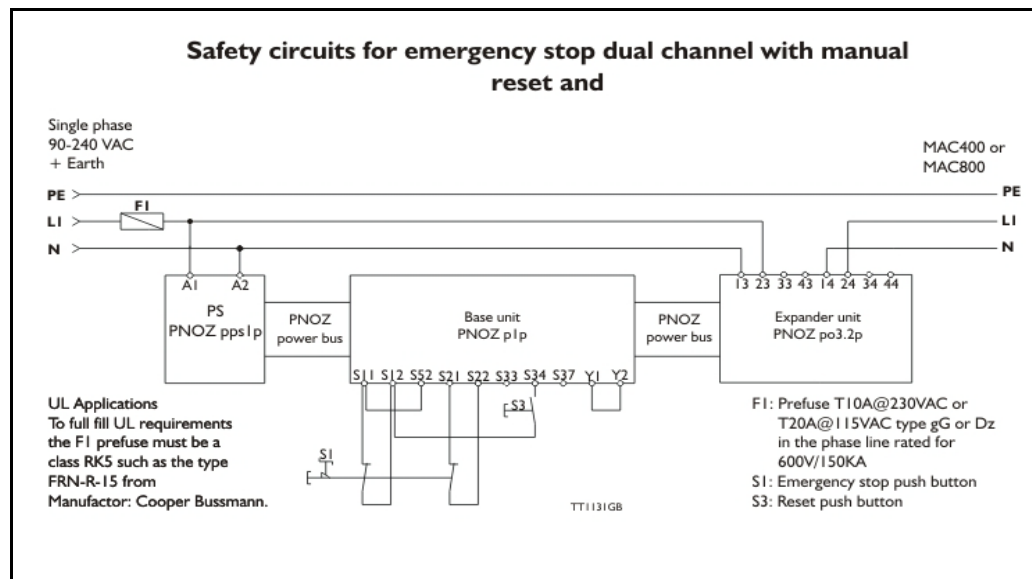

The achievable PL level in accordance with DS/EN ISO 13849 will depend on the MTTF of the components used; using the solutions shown, typically a minimum PL level d would be achieved.

## 5.7 Emergency stop considerations

The enclosure system shown utilizes a manual reset, which is a requirement if personnel may be located inside the enclosure. If this is not the case, an automatic reset can be used.

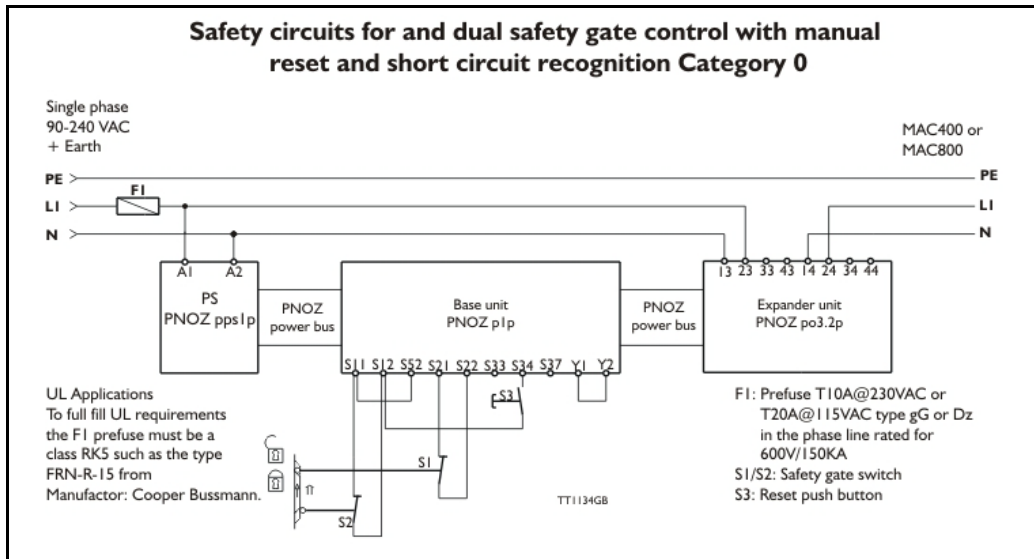

In the case of rotating parts in particular, it may be necessary to take component run-down into account, and therefore it is essential to ensure that access cannot be obtained to hazardous areas until the rotating part has come to a standstill. Alternatively, the enclosure can be equipped with an electro-mechanical lock that only allows the enclosure to be opened when the rotational movement has stopped. The latter solution must be implemented with the same levels of safety as those prescribed by the machine's risk assessment of the guard device implemented.

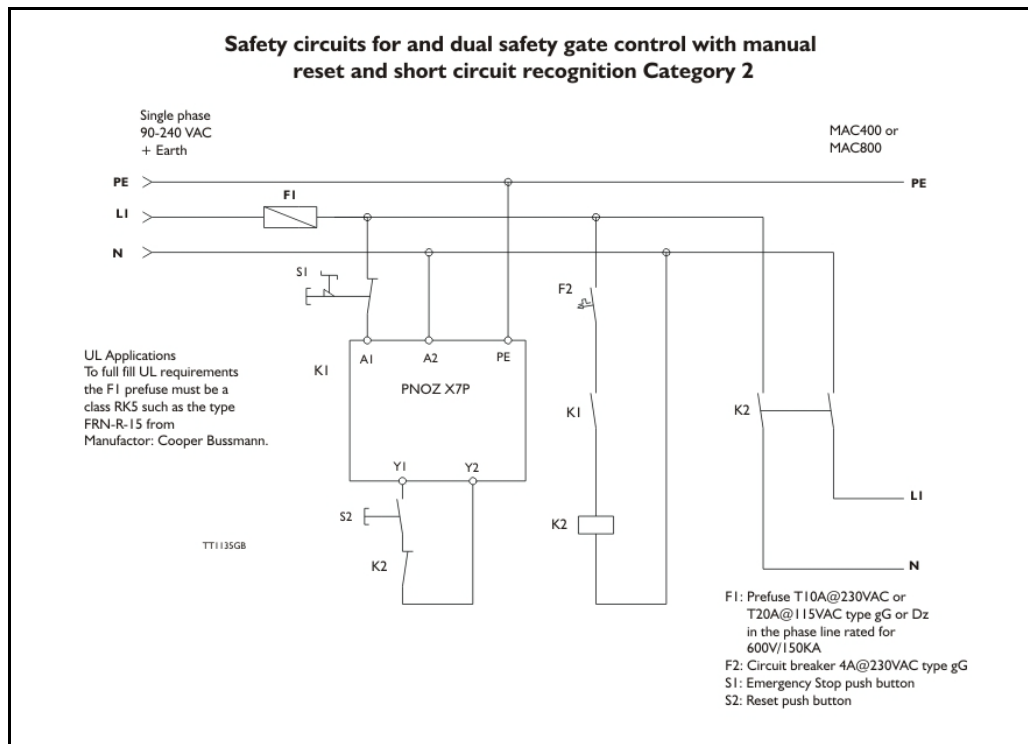

## **5.7 Emergency stop considerations**

---

The examples shown are implemented using equipment from Fa. Pilz, and have been chosen to provide the most simple cabling as possible. Other components and solutions can of course be used.

In the construction of the machine and its safety control systems, efforts should always be made to achieve solutions that ensure the requirements of control systems are as low as possible, in accordance with the principles of safety integration mentioned above.

## 5.8

# Trouble-shooting guide

---

### 5.8.1 Troubles related to communication with the motor

#### **Problem : “RS232 - MacTalk is not communicating with the motor”**

The status at the bottom of the screen shows “\*\*\* No Connection \*\*\*” but the power LED on the motor is lit and the serial cable is connected.

#### **Action :**

- Check that the right COM port is selected in the MacTalk “Setup” menu. If a USB to RS232 converter is used, the COM port normally must be selected as COM3 or COM4.
- Check that the connection to the motor is made according to the specifications. If using only one motor on the RS232 line, the TX-PD must be shorted to TX, otherwise communication can be very unstable. See also the individual descriptions by each module in chapter 4.
- Ensure that a firmware update has not been interrupted before the communication problem was observed. If such an update is aborted/interrupted, it must be restarted and completed before the internal processor is back to normal and can handle communication.

### 5.8.2 Troubles related to the setup of the motor

#### **Problem : “The motor is not behaving as expected”**

#### **Action 1:**

Check that the following registers are set properly:

“Torque” : 300%

“Velocity” : >0

“Acceleration” : >0

“Load” : 1.00

“In position window” : If set too low, it can cause the motor to remain stationary.

Please note that if an expansion module is mounted, it can overrule some of these parameters. Disable the expansion module by setting “I/O type” = “Pulse input” in order to disable the internal communication between the module and the motor. After the fault diagnosis/correction is complete, remember to switch “I/O type” back to “Serial data”.

#### **Action 2:**

Load default by using the “Load default” function in the “Motor” menu.

Alternatively clear the complete memory by using the “Update Firmware” option in the “Updates” menu.

#### **Problem : “The parameter setup is lost after reset”**

The parameters must be saved permanently in the motor using the “Save in flash” button at the top of the main window. When activating this button, the motor will go into passive mode while the parameters are saved. After 5-10 seconds the motor will start up again with the new parameters. If the motor still starts up with the default setup or a setting made at a much earlier stage, the save procedure has failed.

#### **Action :**

Ensure that the motor has the newest firmware (>V5.1). The firmware version for the actual motor can be seen in the status bar.

Ensure also that the MacTalk program is the newest version (>V1.21).

Both Motor and MacTalk can be updated from the internet using the “Update” menu at the top of the main screen.

## 5.8

# Trouble-shooting guide

---

### 5.8.3 Troubles related to mechanical motor behaviour

**Problem : “The motor oscillates or shakes”**

The movement of the motor is very unstable and/or the motor oscillates when stationary.

**Action :**

- Ensure that the LOAD parameter is adjusted to a proper value. Default is 1.00 but when a load is added to the motor, it can be set to a higher value. If the LOAD parameter is set to a value that is too high (or low), the motor can be very unstable.
- Check also that the maximum speed is set within the allowable range specified for the actual supply voltage - see *Power supply (only MAC050 to 141)*, page 87 where a graph illustrates the relationship between supply voltage and recommended speed.
- If none of the above mentioned solutions solves the problem, the filter used in the MAC motor may not be able to handle the actual load. Use the filter-optimize function or contact your nearest JVL representative.

**Problem : “After power up the motor oscillates and there is no communication”**

The LOAD parameter value is set too high and is causing the total supply current to rise above the limit which the power supply can handle. This situation can typically occur if the motor is dismounted from the mechanical load for which the LOAD has been adjusted. Normally the motor will start to oscillate if the LOAD is increased above 1.4-1.8. Default is 1.0 without any mechanical load connected.

**Action :**

The fact that the power supply is overloaded makes the supply voltage drop below the level at which the internal microprocessor in the MAC motor is operational. The only work-around solution to this is a firmware update but all the parameters will be reset to default !

Choose “update firmware” in the “Update” menu and switch on the motor. The firmware update will “catch” the motor before it starts to oscillate and refresh all the settings in the motor.



## 5.9 Bus serial communication

### 5.9.1 Important information concerning RS-232.

Be sure to read this before trying to use RS-232 with any of the JVL modules or motors. Also if you do not plan to use multidrop.

The widely used RS-232 connection is a point-to-point solution, where two systems are connected by at least three wires: A common Grounds and two data wires, where data is transmitted serially from TxD (Transmit Data) pin on the sender to a RxD (Receive Data) pin on the receiver. In addition to this, sometimes hardware handshake signals are used.

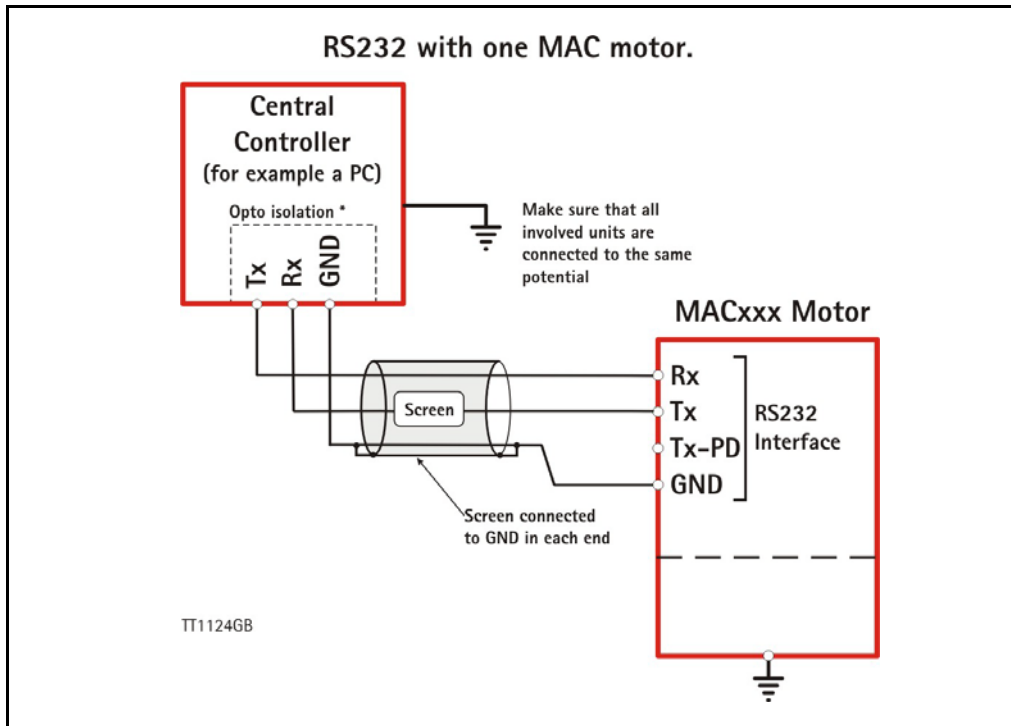

The baud-rate and address factory setting are set to 19200 baud and com port 1. The unit can be set up via the MacTalk program. The motor shall be terminated, the MAC-B1, B2 and B4 expansion modul contain this feature. Opto isolation is recommended, and always use screen cable. The interface cable should not exceed more than 10 meters. Make sure that GND is also connected.

The special RS-232 multidrop solution used with the products covered by this manual allows more than two systems to be connected using the same wires.

With standard RS-232 the TxD pin in each end drives the signal to both high and low voltage levels, and it is an error to connect two or more TxD lines together since they would conflict and generate invalid signal levels.

With the JVL multidrop RS-232 solution, the TxD line is only pulled to an active high through a diode on the modules, and the line has a passive pull-down resistor that connect the line to a negative supply voltage. This allows more than one module to drive the line, but only one module can communicate data at a time.

## 5.9

# Bus serial communication

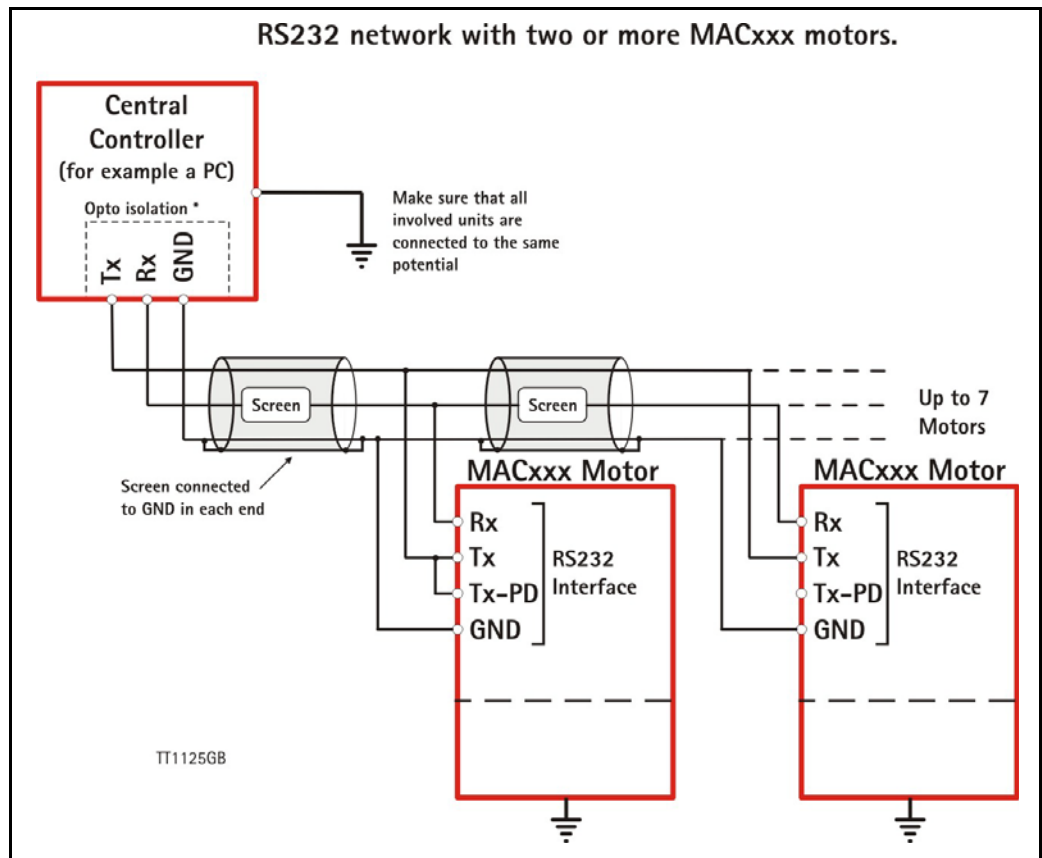

The typical use scenario is that one PC or PLC is connected to two or more JVL modules and each module has its own unique address, so the PC/PLC can address one module at a time and receive an answer on the shared line. It can then address the next module with another address. For this to work, exactly one of the modules on the line must have the passive pull-down resistor enabled. If there is only one module connected to the PC/PLC, that module must have its pull-down resistor enabled.

In the JVL documentation, this system is called TXPD (for TX data resistor Pull-Down).

TXPD is enabled by setting DIP switches on the expansion modules, find the module in section 4 of this user manual.

The baud-rate and the address factory setting are set to 19200 baud and address 1. Opto isolation is recommended, and always use screen cable. The interface cable should not exceed more than 10 meters. Make sure that GND is also connected.

### 5.9.2 Important information concerning RS-485

Please read this before using RS-485 serial-port. This note describes some important details of using this interface.

The most important difference to a standard RS-485 solution is that the MAC00-xx modules drive the line transmit mode for up to one byte-time longer than required.

## 5.9 Bus serial communication

---

The MAC00-xx modules translate between the 5V (TTL level) RS-232 used by the basic motors (MAC050, MAC095, MAC140, MAC141, MAC400, MAC402, MAC800, MAC1500 and MAC3000) and standard RS-485 and RS232 signals

Since the RS-485 interfaces use the standard two-wire coupling, data can travel in only one direction at a time, which means that the line is either in a state where all nodes 'listen' or in a state where one node transmits while all the other nodes 'listen'.

Ideally the node that transmits should stop driving the lines as soon as the last (stop) bit in the last byte it wants to transmit has been sent out. This would allow the other nodes to start transmitting as soon as possible.

It is a classical problem that a device that translates between RS-232 and two-wire RS-485 does not have access to a hardware signal that tells it when to change transmit/listen direction.

On the MAC00-xx modules, the direction is controlled by monitoring activity on the RS-232 transmit signal and drive the RS-485 line for one byte-time at 19200 baud after the last activity was detected.

On the MAC00-xx modules, the direction is controlled by monitoring activity on the RS-232 transmit signal and drive the RS-485 line for one byte-time at 19200 baud after the last activity was detected.

Depending on the data in the last byte transmitted, the line may then be reased from just after the last bit has been transmitted or not until a full byte length after the last byte has been transmitted.

It is required that all other nodes on the RS-485 bus do not start transmitting until a full byte-time has passed since the last byte of a telegram from a MAC00-xx module has been transmitted.

It is a common requirement in many protocols to require a pause of 1.5 bytes-times or more between telegrams. With the JVL MacTalk protocol, this pause can be considered to be two byte-times at 19200 baud and six byte-times at 57600 baud.

## 5.10

## Serial communication

---

### 5.10.1 Controlling the MAC motors and MAC00-xx modules using serial communications.

#### Introduction:

This chapter provides information on the operations that can be performed over serial lines, either RS-232 or RS-485. In addition to regular register reads and writes, a number of typical operations like Reset and Save in Flash memory is described. Additionally, this chapter describes how the MacTalk Windows™ program performs some of the more special operations available from the MacTalk program menus and buttons.

#### General information:

There are two serial channels to the basic MAC motors. One of them always uses the MacTalk protocol and the other one always uses the FastMac protocol.

Communications can be used simultaneously on both channels.

The FastMac channel is a point-to-point connection where there can be only one client communicating with the basic motor, while the MacTalk channel can be used to connect several motors to one controlling computer or PLC.

The FastMac channel consists of two sets of differential signals, one for data sent to the motor and one for data sent from the motor. This provides a high degree of noise immunity which allows the protocol to have less overhead for error checking and thus work very fast.

Both of these protocols use binary data rather than text data. It is not possible to use a text terminal program like Windows Hyper Terminal to communicate on any of these protocols.

Depending on the type of MAC00-xx module mounted on the motor, the MacTalk channel can be made available as RS-232 or RS-485 and on the wireless modules as a Bluetooth serial port or a virtual COM port over TCP/IP.

Note that the MAC00-xx modules drive the RS-232 and RS-485 lines in a slightly non-standard way, which must be taken into account. This is described in detail elsewhere in this manual, but the overall differences are that, for RS-485, the modules drive the line in transmission mode up to approximately 560 micro-seconds longer than necessary and for RS-232, the TxD line is only driven actively high, while it must be pulled passively low by a resistor (provided on the module and selectable via a DIP-switch). This special non-standard RS-232 coupling allows several motors to be connected to a single controlling computer or PLC, much like RS-485.

The MAC motors can be mounted with either 'intelligent' MAC00-xx modules that have an integrated processor to handle the communications to the basic motor or they can be mounted with 'dummy' modules that just do minimal hardware translation of the signals but allows the user access to the FastMac protocol.

When mounted with 'intelligent' modules, the MacTalk channel is shared between the modules and the basic motor. This means that data received on the module interface will be received by both the module and the motor at the same time, while data sent from either the module or the motor will be combined in hardware and sent via the module interface (connectors or cables).

Some telegrams are handled and answered by the motor and other telegrams are handled and answered by the module. No telegrams are handled by both the motor and the module except for the command to select a baud rate of 57600 baud.

An exception to this coupling is the series of MAC00-FSx modules. These 'intelligent' modules do not use the FastMac channel, but allows the user exclusive access to it. They share the MacTalk channel in the same way as the other 'intelligent' modules, but with the additional functionality that the FSx module uses the MacTalk channel to communicate with the basic motor. This means that the motor can experience conflicting traffic when both the FSx module and an outside computer try to talk on the line at the same time. The FSx module detects traffic and will only start sending data to the motor on the MacTalk channel after the channel has been idle for several seconds. On FSx modules the RS-232 line should therefore be used only for setup and firmware updates, and the high-speed RS-485 line of the FSx modules should be used for all production data traffic.

Capabilities of the FastMac protocol:

The FastMac protocol can be used to read and write all registers in the basic motor via telegrams termed FlexMac commands. It also has a number of single-byte commands that can copy dedicated preloaded registers into their corresponding target registers, select modes of operation and reset certain errors. In addition a special sequence can change from 19200 to 57600 baud.

The FastMac protocol can **not** be used to reset the basic motor, perform save in the motors flash memory, enter or exit Safe Mode, read the motors sample buffer or read a block of registers from the motor. These operations are not available through register reads and writes. This implies that intelligent modules cannot be used to reset the motor from their fieldbusses.

Capabilities of the MacTalk protocol:

The MacTalk protocol can be used to read and write all registers and can execute the set of commands that the FastMac protocol cannot.

The MacTalk protocol can **not** be used to send single-byte commands, but the same operations can be performed through register reads and writes.

The error/status register:

This section describes how to handle the bitmapped combined error and status register Register 35, including how to clear errors, describes errors that can not be cleared without power cycling the motor, identifies best practice ways of operating the register for a number of typical applications. Some of these applications include how to control whether the motor performs relative or absolute position movements and how to move back into the normal working range after having been outside it.

This section does not describe all the bits in detail, but describes the different groups of functions the bits in this register can assume.

Note that even though the Error/Status register bits are similar in the MAC050-141 and the MAC400 up to MAC3000 motors, they are not the same. The bits that have a Control function can be located either in Register 35, Error/Status or in Register 36, Control-Bits, at another motor type. Check the technical manual for the product you're using, and be aware of the differences if you're combining MAC050-141 motor with MAC400 up to MAC3000 motors in the same application.

There are three groups: Errors, Status and Control bits.

**Errors** are grouped into Temperature related errors, Electrical errors, and Mechanical errors. Some errors can be reset from the serial lines, while other errors are so critical that the motor can not continue safe operation, so to continue operation the power to the motor must be turned off and then on again.

**Status** bits simply reflect the updated normal status of the motor, like whether the target position or velocity has been reached. Some status bits can be considered early-warning bits like that the voltage of the control power supply has been measured to a low value. If the voltage is measured to an even lower voltage, the motor will stop with a hard error that requires reset because the risk of continuing operation is too high after the control circuits may have been partly reset and entered an indeterminate state.

**Control** bits include bit 14 in MAC800 that must be set by the user to be able to move the motor back into the position limit range. The motor will not move if software position limits are active (non-zero) and the motor has moved outside the limits. The typical case is when the motor is normally working in Position mode where the software position limits will automatically prevent it from moving outside the limits, and then if the motor is switched into another mode, like Velocity mode, where position limits do not apply, and run outside the position range.

Another example is bit 9 in the on the MAC050-141 motors. When using FastMac commands to transfer one of the P1..P8 register to P\_SOLL, bit 9 selects whether to simply copy the value or to add it to the existing contents of P\_SOLL.

See the Technical Manual for the MAC50.141 and the Technical manual for the MAC800 for accurate bit descriptions.

Resetting the motor and module:

This section describes the ways to reset the motor and/or the module, and makes several notes on things to consider to prepare for a reset and how to continue operation after a reset.

Reset errors

Some errors can be reset from software, while others are simply too critical to attempt further operation and require the power supply to be turned off and then on again to reset the errors.

There are basically two ways of resetting the errors in the Error/status register 35.

One way is to read the entire register, then zero the error bits but leave the other bits unchanged, and finally write the entire register back to the motor. This is the method to use with the MacTalk protocol.

The other way is to send a single-byte FastMac command of 97 (decimal) / 61 (hex). All intelligent modules provide a way to send FastMac commands, either over the fieldbus or from the nano-PLC program.

Mode 256..258

As described under the Reset command, there are a small number of operations that manage copying of default register values between the factory default values, the values last saved by the user through a Save in Flash operation, and the actual working register values kept in RAM.

This section describes how to use these operations in a best practice way.

### Changing baud rate

This section describes how to change between the baud rates supported by the motors and modules in those cases where that is allowed.

At every start-up, both the basic motors and the MAC00-xx modules start at a speed of 19200 bits per second on both the FastMac channel and the MacTalk channel. Note that the speed will not be saved in the motor or module flash memory, which ensures that another motor or module can be easily interchanged.

The speed can then be changed to 57600 baud, but can not be changed back to 19200 baud without resetting the motor and module.

At the time of this writing, only MAC800 and the MAC00-FCx modules support 57600 baud.

To change the speed on the FastMac channel with intelligent modules follow these steps:

- 1: The basic motor must be set to passive mode (the mode register, register 2, must be zero).
- 2: Send a special command to the module through its Fieldbus interface. For the MAC00-FCx this is CANopen®, and a command is sent by writing a value via SDO to object 2010 hex.

When the command number 5 is written to object 2010, the module will perform the steps to change the baud rate in both the module and the basic motor, but only on the FastMac channel – the MacTalk channel is unaffected. This change of baudrate will last about eight milliseconds, during which no other communications can occur between the module and the motor.

To change the speed on the MacTalk channel follow these steps:

- 1: Set the motor to Safe Mode (the mode register, register 2, must be 15).
- 2: Send a special command telegram of <58><58><58><FF><00><AA><AA>, where the <FF><00> is the motor address. As usual this can be <FF><00> to address any motor or the address of a specific motor followed by a bitwise inverted byte. E.g. <04><FB>.
- 3: Wait for 10 milliseconds for a reply. If a reply of <11><11><11> is received, it means the motor can not change to the new baudrate, probably because it is not in Safe Mode or if some other error has occurred. If no reply is received within the 10 ms, it can be assumed that the motor has changed to 57600 baud, and further communications can continue at the higher speed.

### General notes on the MAC00-xx interface modules operation

Modules generally have two functions. One is to translate between an industrial fieldbus like CANopen®, DeviceNet, ProfiBus and high speed RS-485. The other is to execute small userdefined programs much like a traditional PLC. During execution, the modules communicate extensively with the basic motor over a serial connection that is typically much slower than the fast fieldbusses.

The following points are important to consider to understand the limitations regarding module capabilities:

- When writing a value to the basic motor via an intelligent module, the write operation is queued up in a buffer in the module, which can typically hold up to 16 operations. The values are written to the motor at the speed of the FastMac channel, either 19200 or 57600 baud. The FastMac protocol has some overhead, and the basic motor only performs operations once per sample period, so a full register write (or read) can take up to almost 20 milliseconds at 19200 baud. The normal time is 10.5 to 15 milliseconds for a single register transfer.

- When reading one or more register values from the basic motor, the remaining operation of the module waits for the operation(s) to complete before continuing operation. For the fieldbus modules, this means that the response time for a read operation can be quite long, since in addition to the requested read operation, other read and write operations can be queued up and must complete before the requested read operation can be completed and the value can be returned over to fieldbus. For the PLC-like modules, the long transmission time means that a program line that manipulates a motor register in a way that requires reading can take 20 or more milliseconds to execute.
- Some fieldbusses, like CANopen® expect that the motor is able to transmit a value when it has changed more than a certain amount since the last time it was transmitted. The current fieldbus modules do not have this capability since it would load the serial link to the motor too much to continuously poll the value of motor registers.

#### Module register addressing and module commands

Some of the modules have registers to control their behaviour. These registers are addressed in another way than the registers in the basic motor. Examples include registers that control digital inputs and outputs local to the module.

Additionally, the modules containing a nano-PLC have 256 bytes of memory local to the module, that can be used to create variables that can be used during program execution, typically for calculations. These local memory variables are much faster to use than the registers in the basic motor since they are not transmitted over the relatively slow serial line.

These module registers are available over the MacTalk protocol and over the fieldbusses. On the MacTalk protocol, the module registers are addressed differently for each module type.

The general idea is that each module type has its own range of commands that is different from the range used by the basic motor.

#### The three special commands Reset Motor, Clear Errors and Save in Flash:

##### Save in Flash:

Pressing this button in MacTalk will send a special command over the serial line (RS-232 or RS-485) that will cause the motor and module (if present) to save the setup registers to flash memory. Flash memory is permanent storage that will keep its value even though the power supply has been turned off.

At the next power up, the motor and module will load the saved values from flash. Note that the motor, but not the module, will automatically perform a reset as soon as it has finished the Save in Flash operation.

The operations performed by MacTalk are:

- 1: Set the motor into Safe Mode by sending a telegram of <54><54><54><FF><00><AA><AA> and wait for an answer with data <11><11><11>. If the motor uses an address instead of using the broadcast address 255 (FF), substitute the <FF><00> with <address><inverted address>. See the MacTalk protocol description for more information.
- 2: Continue sending the telegram <56><56><56><FF><00><AA><AA> and wait for the <11><11><11> sequence. As soon as any communications error occurs, like a wrong answer or a missing answer/timeout, it means the motor has started its reset sequence. Again, you can substitute a specific motor address for the broadcast address <FF><00>.



- 3: If a module is present, send a Module Reset telegram to the module. See the section Reset Motor below for details on resetting a module. Note that the different module types require different telegrams to reset.

Saving to flash can only be done over the serial lines RS-232 and RS-485. It can not be done over any of the fieldbus modules with ProfiBus, CANopen®, DeviceNet or the high-speed RS-485 FSx modules. Also the Rx and RxP modules can not cause a Save in Flash from the nano-PLC program. Note that the Bluetooth and WLAN modules are similar to the RxP modules in that the wireless link replaces the RS-485 interface. It is therefore supported to send Reset sequences over Bluetooth and WLAN.

Note that saving parameters to flash can only be performed a few thousand times before the flash wears out. The number of times may differ significantly between units. If the flash wears out, the motor will load a default set of register values at start up. The electronics in the motor must be repaired or replaced to be able to save reliably to flash again. JVL recommends to avoid saving in flash when it is not strictly necessary.

#### Clear Errors:

Pressing this button will clear the error-bits in the Error/Status motor register 35.

With the MAC800 motor, MacTalk will normally write a value of zero to register 35. However, if the Position Limits error bit is set, it will pop up and ask the user if the position limits should be temporarily disabled until the position is back inside the limits set. This is to handle the situations where the motor is moved outside the position limits while working in another mode, like Velocity mode. If the user answers Yes to the prompt, MacTalk will write the value 4000 hex, where only bit 14 is set. Bit 14 will be cleared automatically by the MAC800 firmware as soon as the actual position is again inside the position limits. If bit 14 is not set, the motor will refuse to move while outside the position limits – at least in one of the directions, depending on the firmware version

With the MAC50-141 motors, MacTalk will normally write a value to register 35 where all bits are zero except it will leave 9 and 10 unchanged. This means it will perform a bit-wise ORing of the value last read from the register with 600 hex, and then write the result back to register 35.

Other than that, MacTalk handles the Position Limits bits just like with the MAC800, see the above paragraph for more information.

#### Reset Motor:

Pressing this button will send a reset command to the motor and to the module, if present.

The operations performed by MacTalk are:

- 4: Set the motor into Passive Mode (set register 2 = to zero) by sending a telegram of <52><52><52><FF><00><02><FD><00><FF><00><FF><AA><AA> and wait for an answer with data <11><11><11>. If the motor uses an address instead of using the broadcast address 255 (FF), substitute the <FF><00> with <address><inverted address>. See the MacTalk protocol description for more information.
- 5: Continue sending the telegram <57><57><57><FF><00><AA><AA> and wait for the <11><11><11> sequence. As soon as any communications error occurs, like a wrong answer or a missing answer/timeout, it means the motor has started its reset sequence. Again, you can substitute a specific motor address for the broadcast address <FF><00>.

## 5.10

## Serial communication

---

- 6: If a module is present, send a Module Reset telegram to the module. See the section Reset Motor below for details on resetting a module. Note that the different module types require different telegrams to reset.

The motor can only be Reset over the serial lines RS-232 and RS-485 – or by switching the power supply off and on. It can not be done over any of the fieldbus modules with ProfiBus, CANopen®, DeviceNet or the high-speed RS-485 FSx modules. The Bluetooth and WLAN modules can use reset since their wireless links replace the RS-485 interface, but note that it may take longer after a reset before a connection can be re-established.

As an alternative to Reset, there are ways to load all the register values from factory defaults or the last set of values saved to user flash. Note however, that loading all the registers will not clear all types of errors. This is intentional, since some errors are so serious that the motor can not continue safe operation. The errors that can not be cleared without power cycling are XXXX XXXX XXXX.

To use the functions to manipulate factory defaults and/or user flash, three steps must be taken:

- 1: Set the motor into Safe Mode by writing the value 15 to the mode register (register 2).
- 2: Write one of the values described below to the mode register.
- 3: Wait for the mode register to automatically change away from that value – this will typically take a few tens of milliseconds, but may vary. Just continue reading the register until the value changes. After this, set the motor into the desired operating mode.

With the MAC50-141 motors, the following functions are currently implemented:

- 100h (256): Load factory defaults AND save to user flash
- 101h (257): Load factory defaults (do NOT save to user flash)
- 102h (258): Load all registers from user flash.

With the MAC800 motor, the following functions are currently implemented:

- 100h (256): Load factory defaults AND save to user flash
- 101h (257): Load all registers from user flash.
- 102h (258): Save all registers to user flash

Note that after loading all register from either user flash or the factory defaults, the firmware will clear or preset some of the registers, like clearing the follow error and setting the actual position to zero to resemble a cold start after power up.

The value 100h (256 decimal) is also used by the Load Defaults function on the Motor menu in MacTalk.

## 5.11 MacTalk communication

Only MAC050 to I4I

When using the RS232 or RS422 serial links, it is possible to access all the internal registers in the motor.

This gives the same possibilities as using the general installation and monitoring program MacTalk.

In addition to these features, many more are accessible. In total, the MAC motor contains more than 200 internal registers such as nominal velocity, actual position, etc. but please note that several registers are not for the normal user and damage may occur if the contents of these registers is changed.

The following pages describe the communication protocol that is used when communicating with the MAC50 - I4I motors.

### 5.11.1 Serial Quick Guide (MacTalk protocol)

This section describes control of the MAC motor via the serial interface (RS232/485 connector on the MAC00-B1 or equivalent module).

The interface is RS232 compatible and uses 19200 baud with 8 data bits and no parity.

The MAC motor is completely controlled by reading and writing to registers. The registers are numbered 1-255. The width of the registers is 16 bits or 32 bits. To protect the communication from errors, the data is transmitted twice.

First the data byte is transmitted and then an inverted version (255-x) is transmitted.

The easiest way to become familiar with the registers and MAC communication is to use the *MacRegIO* program. This program lists all of the registers, and the serial commands sent and received can be monitored.

## 5.11

## MacTalk communication

Only MAC050 to I4I

### 5.11.2 Writing to a register

Controller sends	MAC motor response
<Write><Address><RegNum><Len><Data><End>	<Accept>

#### Block description

Block Name	Protected (1)	Example	Description
<Write>	No	52h,52h,52h	Write command
<Address>	Yes	07h,F8h (Address 7)	The address of the MAC motor
<RegNum>	Yes	05h,FAh (RegNum 5)	The register number to write to
<Len>	Yes	02h,FDh (Len = 2)	The number of data bytes
<Data>	Yes	E8h,17h, 03h,FCh (Data = 1000)	The data to write to the register
<End>	No	AAh, AAh	Command termination
<Accept>	No	11h, 11h,11h	Accept from MAC motor

(1) Protected means that these data must be sent twice, first non-inverted and then inverted.

#### Example 1:

Writing 600 (258h) to register 5 (16 bit) to the MAC motor with address 8.

Transmit:52h,52h,52h - 08h,F7h - 05h,FAh - 02h,FDh - 58h,A7h,02h,FDh - AAh, AAh

Response: 11h, 11h, 11h

#### Example 2:

Write 230,000 (38270h) to register 3 (32 bit) to the MAC motor with address 7.

Transmit:52h,52h,52h - 07h,F8h - 03h,FCh - 04h,FBh -

70h,8Fh,82h,7Dh,03h,FCh,00h,FFh - AAh, AAh

Response: 11h, 11h, 11h

## 5.11

# MacTalk communication

Only MAC050 to I4I

### 5.11.3 Reading from a register

Controller sends	MAC motor response
<Read><Address><RegNum><End>	<Write><Address><RegNum><Len><Data><End>

#### Block description

Block Name	Protected (1)	Example	Description
<Read>	No	50h,50h,50h	Read command
<Address>	Yes	07h,F8h (Address 7)	The address of the MAC motor
<RegNum>	Yes	05h,FAh (RegNum 5)	The register number to read
<End>	No	AAh, AAh	Command termination
<Write>	No	52h,52h,52h	Write command
<Address>	Yes	00h,FFh (Address 0)	This will always be 0, because this is the address of the master
<RegNum>	Yes	05h,FAh (RegNum 5)	This will always be the same as requested
<Len>	Yes	04h,FBh (Len = 4)	The length will always be 4
<Data>	Yes	E8h,17h, 03h,FCCh, 00h, FFh, 00h,FFh (Data = 1000)	The data read from the register
<End>	No	AAh, AAh	Command termination

(1) Protected means that these data must be sent twice, first non inverted and then inverted.

#### Example 1:

Reading the value of register 5 from MAC motor with address 8.

Transmit: 50h,50h,50h - 08h,F7h - 05h,F6h - AAh, AAh

Response: 52h,52h,52h - 00h,FFh - 05h,F6h - 04h,FBh - 58h,A7h,02h,FDh,00h,FFh,00h,FFh - AAh, AAh

The value of register 5 was 500 (258h).

#### Example 2:

Reading the value of register 3 from MAC motor with address 8.

Transmit:50h,50h,50h - 08h,F7h - 03h,FCCh - AAh, AAh

Response:52h,52h,52h - 00h,FFh - 05h,F6h - 04h,FBh - 70h,8Fh,82h,7Dh,03h,FCCh,00h,FFh - AAh, AAh

The value of register 3 was 230,000 (38270h).

**5.11.4 Application examples****Setting mode 1 (Position mode)**

This command writes 1 to register 2 (MODE\_REG) on motor 8.

Transmit: 52h,52h,52h - 08h,F7h - 02h,FDh - 02h,FDh - 01h,FEh,00h,FFh - AAh, AAh

Response: 11h,11h,11h

**Setting position 100,000**

This command writes 100,000 to register 3 (P\_SOLL) on motor 8.

Transmit: 52h,52h,52h - 07h,F8h - 03h,FC h - 04h,FBh -

A0h,5Fh,86h,79h,01h,FEh,00h,FFh - AAh, AAh

Response: 11h,11h,11h

**Reading the motor status**

This command reads register 35 (ERR\_STAT) from motor 8

Transmit: 50h,50h,50h - 08h,F7h - 23h,DCh - AAh, AAh

Response: 52h,52h,52h - 00h,FFh - 23h,DCh - 04h,FBh -

10h,EFh,00h,FFh,00h,FFh,00h,FFh - AAh, AAh

The motor responded with ERR\_STAT = 0010h - meaning "In Position".

**Setting the maximum speed**

This command sets the maximum speed to 1000 RPM = 2097 pulses/sample (2097 = 831h).

This is done by writing to register 5 (V\_SOLL)

Transmit: 52h,52h,52h - 08h,F7h - 05h,FAh - 02h,FDh - 31h,CEh,08h,F7h - AAh, AAh

Response: 11h,11h,11h

**Reading the actual position**

This command reads register 10 (P\_IST) from motor 8

Transmit: 50h,50h,50h - 08h,F7h - 0Ah,F5h - AAh, AAh

Response: 52h,52h,52h - 00h,FFh - 0Ah,F5h - 04h,FBh -

08h,F7h,BDh,42h,03h,FC h,00h,FFh - AAh, AAh

The position was 245,000 (3BD08h)

## 5.12

## Internal registers

---

### 5.12.1 Internal registers in the MAC motors

In order to control the operation of the motor a larger number of registers exist. These are accessible via the serial communication channels or via one of the industrial bus modules such as the Ethernet modules, Profibus or CAN-open modules.

The general windows installation and monitor program MacTalk also have access to most of these registers. MacTalk offers a more user friendly and easy to understand interface.

It may however be necessary to access the registers directly in for example systems using one of the many industrial bus modules as mentioned above.

For this purpose the next pages show the complete list of registers and explain the function of each register.

Please notice that the registers in the MAC50 to 141 is not fully equal to the registers in the MAC400 and 800 motors.

Each group of motors therefore have its own register list.

Most of the most common used registers are though equal but scaling and the length (16bit or 32bit) of the registers may vary from between the 2 motor families.

## 5.12

## Internal registers

Only MAC50 - 141

### 5.12.2 MAC50 to 141 register list.

The following list is only valid for the MAC50, MAC95, MAC140 and MAC141 motors including sub-versions.

Reg. Nr.	Firmware / MacRegIo Name	MacTalk Name	Range / Default	Size / Access	Unit	Description
0	N/A	N/A	N/A	N/A	N/A	Dummy register, do not use
1	PROG_VERSION	Displayed on bottom right status line.				Firmware version number.
2	MODE_REG	Startup mode / Change actual mode				<p>The actual operating mode of the drive.</p> <p>In general, the motor will either be passive, attempt to reach a certain position, attempt to maintain a constant velocity or attempt to produce a constant torque. The various modes define the main type of operation as well as what determines the setpoint for that operation.</p> <p>The special cases 256..258 are used to perform a few special operations on the entire set of registers.</p> <p>Supported values are:</p> <p>0 : <b>Passive mode.</b> The axis is not controlled by the drive, and can easily be moved by hand or external mechanics.</p> <p>1 : <b>Velocity mode.</b> The drive will attempt to run the motor at a constant velocity selected by Reg5, V_SOLL, without violating the maximum torque or acceleration.</p> <p>2 : <b>Position mode.</b> The drive will at all times attempt to move the actual motor position to the position selected by Reg3, P_SOLL, without violating the maximum velocity, torque or acceleration.</p> <p>3 : <b>Gear Position mode.</b></p> <p>4 : <b>Analogue torque mode.</b></p> <p>5 : <b>Analogue velocity mode.</b></p> <p>6 : <b>Analog Velocity Gear mode.</b></p> <p>7 : <b>Manual current mode.</b></p> <p>8 : <b>Step response test mode.</b></p> <p>9 : <b>Internal test mode.</b></p> <p>10 : <b>Brake mode.</b></p> <p>11 : <b>Stop mode.</b></p> <p>12 : <b>Torque based zero search mode.</b></p> <p>13 : <b>Forward/only zero search mode.</b></p> <p>14 : <b>Forward+backward zero search mode.</b></p> <p>15 : <b>Safe mode.</b></p> <p>16 : <b>Analogue velocity with deadband mode.</b></p> <p>17 : <b>Velocity limited Analog Torque mode.</b></p> <p>18 : <b>Analogue gear mode.</b></p> <p>19 : <b>Coil mode.</b></p> <p>20 : <b>Analogue bi-position mode.</b></p> <p>21 : <b>Analogue to position mode.</b></p> <p>22 : <b>Internal test mode.</b></p> <p>23 : <b>Internal test mode.</b></p> <p>24 : <b>Gear follow mode.</b></p> <p>25 : <b>IHOME mode.</b></p> <p>256</p> <p>257</p> <p>258</p>
3	P_SOLL, 32-bit	Position	-67M - +67M	32 bit R / W		The target position that the drive will attempt reach in position related modes.
4	(high word of P-SOLL)	-	-			-



## 5.12

## Internal registers

Only MAC50 - I41

Reg. Nr.	Firmware / MacRegIo Name	MacTalk Name	Range / Default	Size / Access	Unit	Description
5	V_SOLL	Max. Velocity				The maximum velocity the motor is allowed to use.
6	A_SOLL	Acceleration			Counts/ Sample	The maximum acceleration in counts/sample <sup>2</sup> the drive is allowed to use during normal operation. Also note Reg32, ACC_EMERG, used during emergency stops.
7	T_SOLL	Torque	0-1023		-	The maximum torque that the drive is allowed to use. The value 1023 corresponds to 300% of nominal load, and is the absolute maximum peak torque allowed. The value 341 gives 100% (nominal load).
8	P_FNC, 32-bit (Sometimes named P_SIM)				Counts	
9	(high word of P_FNC/P_SIM)					
10	P_IST, 32-bit	Actual position				The actual motor position measured by the internal encoder. Updated every 1.9ms. Note that this register is maintained incrementally, which means that the user can update it to offset the working range. When updating when the drive is not in Passive mode, P_IST and P_SOLL should be updated together in an atomic operation, using Reg163, P_NEW, or other special measures. Also note that the firmware will change this register after a zero search operation has completed.
11	(high word of P_IST)	-	-			-
12	V_IST					Actual velocity of the drive.
13	KVOUT	Load factor				Ratio of the total inertia driven by the drive to the inertia of the motors rotor itself.
14	GEARF1					Gear factor 1, Nominator
15	GEARF2					Gear factor 2, Denominator
16	I2T					Energy dissipated in the motor windings.
17	I2TLIM					Safety limit for I2T above. Motor will set an error bit if I2T gets above I2TLIMIT.
18	UIT					Energy dissipated in the internal power dump.
19	UITLIM					Limit for Reg18, UIT. Motor will set an error bit if UIT gets above UITLIM
20	FLWERR, 32-bit					A measure of how far the drive is from its ideal regulation goal. This value is calculated differently in the various modes, and can mean things like pulses from theoretical position or difference in actual velocity to V_SOLL. Contact JVL for more detailed information for specific modes.
21	(high word of FLWERR)					
22	FLWERRMAX, 32-bit					When Reg20, FLWERR, exceeds this limit, an error bit is set in Reg35, ERR_STAT, and the motor will stop if Reg22 is non-zero. Usually this value is set experimentally to detect situations where a movement is blocked or fails.
23	(high word of FLWERRMAX)					
24	FNCERR, 32-bit					Shows how much the motor is behind the ideal movement; precise operation depends on mode. When this accumulated value exceeds Reg26, FNCERRMAX, the FNC_ERR bit is set in Reg35, ERR_STAT and the motor will stop.

TI1521GB

# 5.12

# Internal registers

Only MAC50 - I4I

Reg. Nr.	Firmware / MacRegIo Name	MacTalk Name	Range / Default	Size / Access	Unit	Description
25	(high word of FNCERR)					
26	FNCERRMAX, 32-bit					
27	(hi-word of FNCERRMAX)					
28	MIN_P_IST, 32-bit					
29	(hi-word of MIN_P_IST)					
30	MAX_P_IST, 32-bit					
31	(hi-word of MAX_P_IST)					
32	ACC_EMERG					
33	INPOSWIN					
34	INPOSCNT					
35	ERR_STAT					<p><b>Bit 0, I2T_ERR</b> Too much energy dissipated in the motor windings. Set when Reg16, I2T, exceeds Reg17, I2TLIM</p> <p><b>Bit 1, FLW_ERR</b> The actual position is too far behind the ideal position. Set when FLWERRMAX is non-zero, and FLWERR exceeds FLWERRMAX.</p> <p><b>Bit 2, FNC_ERR</b> The value of Reg24, FNCERR, exceeded the value of Reg26, FNCERRMAX.</p> <p><b>Bit 3, UIT_ERR</b> The value of Reg18, UIT, exceeded the value of Reg19, UITLIM.</p> <p><b>Bit 4, IN_POS</b> For position-related modes: The actual position was detected to be inside the InPosition window (Reg33, INPOSWIN) at least the number of times defined in Reg34, INPOSCNT. For other modes: Depends on mode; for velocity related modes, this bit means AtVelocity; for other more special modes, this bit is calculated differently, ask JVL for details.</p> <p><b>Bit 5, ACC_FLAG</b> The drive is currently accelerating (the velocity is increasing).</p> <p><b>Bit 6, DEC_FLAG</b> The drive is currently decelerating (the velocity is decreasing).</p> <p><b>Bit 7, PLIM_ERR</b> One of the software position limits was exceeded, drive will go into stop mode, then passive mode automatically.</p> <p><b>Bit 8, FRAME_ERR_TX</b> A framing error was detected during the last reception on the FastMac protocol.</p> <p>Continued next page</p>

TR1522GB

# 5.12

# Internal registers

Only MAC50 - I4I

Reg. Nr.	Firmware / MacReglo Name	MacTalk Name	Range / Default	Size / Access	Unit	Description
35	ERR_STAT (cont. from last page)					<p><b>Bit 9, RELPOSPSOLL</b>  <b>Bit 10, RELPOSPFNC</b>                      These two bits determine what will happen when one of the eight general purpose position registers, P1-P8 is activated through either a FastMac command (including activating s register group), through writing to Reg43, P_REG_P,on changes in bi-position mode or during manual resynchronization.                      If both are zero, the P register gets copied to the target register(s).                      If Bit 9 is set, the value of Reg3, P_SOLL, is added to the target register(s) to make a relative movement.                      If Bit 10 is set, the value of Reg8, P_FNC, is added to the target register(s) to make a relative movement.</p> <p><b>Bit 11, IX_ERR</b>                      The current in at least one of the motor windings was measured to be too high, possibly because of bad current loop filter settings. Values for the current filter have been overwritten with default values. Specifically registers 106 through 111, 127 and 128.</p> <p><b>Bit 12, UV_ERR</b>                      The motor power supply voltage (Reg151, U_SUPPLY) was measured to be below the value in Reg152, U_MIN_SUP and the drive was configured to set an error bit in case of undervoltage.</p> <p><b>Bit 13, UV_DETECT</b>                      The motor power supply voltage (Reg151, U_SUPPLY) was measured to be below 1.25 times the value in Reg152. This is a warning bit, not an error.</p> <p><b>Bit 14, DIS_P_LIM</b>                      When this bit is set (during zero search or by the user), the drive will disable its position limits so it can move also outside the position limit range. This bit is cleared automatically when the actual position gets inside the position range again.</p> <p><b>Bit 15, SSI_ERROR</b></p>

TN523GE

# 5.12

# Internal registers

Only MAC50 - I4I

Reg. Nr.	Firmware / MacRegIo Name	MacTalk Name	Range / Default	Size / Access	Unit	Description
36	CNTRL_BITS					Bit 0, USRINTF0 Bit 1, USRINTF1 Bit 2, PULSEDIR Bit 3, INPSIGN Bit 4, HICLK Bit 5, HALL_INT Bit 6, RECORDBIT Bit 7, REWINDBIT Bit 8, RECINNERBIT Bit 9, AUTO_RESYNC Bit 10, MAN_RESYNC Bit 11, INDEX_HOME Bit 12, REL_RESYNC Bit 13, HALL_C Bit 14, HALL_B Bit 15, HALL_A
37	STARTMODE					
38	P_HOME, 32-bit					
39	(hi-word of P_HOME)					
40	V_HOME					Velocity used during Zero Search/Homing
41	T_HOME					Negative => home on falling edge of AN_INP
42	HOMEMODE					Used by FastMac commands
43	P_REG_P					
44	V_REG_P					
45	A_REG_P					
46	T_REG_P					
47	L_REG_P					
48	Z_REG_P					
49	POS0 / P1, 32-bit					
50	(hi-word of P1)					
51	POS1 / P2, 32-bit					
52	(hi-word of P2)					
53	POS2 / P3, 32-bit					
54	(hi-word of P3)					
55	POS3 / P4, 32-bit					
56	(hi-word of P4)					
57	POS4 / P5, 32-bit					
58	(hi-word of P5)					
59	POS5 / P6, 32-bit					Bit 0, COIL_START_DIR Bit 1, COIL_POS_CMD Bit 2, COIL_PWR_CMD Bit 3, COIL_POS_ACCEPT Bit 4, COIL_PWR_FLASH
60	(hi-word of P6)					
61	POS6 / P7, 32-bit					
62	(hi-word of P7)					
63	POS7 / P8, 32-bit					
64	(hi-word of P8)					
65	VEL0 / V1					
66	VEL1 / V2					
67	VEL2 / V3					
68	VEL3 / V4					
69	VEL4 / V5					
70	VEL5 / V6					
71	VEL6 / V7					
72	VEL7 / V8					
73	ACC0 / A1					
74	ACC1 / A2					
75	ACC2 / A3					
76	ACC3 / A4					
77	TQ0 / T1					
78	TQ1 / T2					
79	TQ2 / T3					
80	TQ3 / T4					

T11524GB

## 5.12

## Internal registers

Only MAC50 - I4I

Reg. Nr.	Firmware / MacRegIo Name	MacTalk Name	Range / Default	Size / Access	Unit	Description
81	LOAD0 / L1					
82	LOAD1 / L2					
83	LOAD2 / L3					
84	LOAD3 / L4					
85	ZERO0 / Z1					
86	ZERO1 / Z2					
87	ZERO2 / Z3					
88	ZERO3 / Z4					
89	KFF3					
90	KFF2					
91	KFF1					
92	KFF0					
93	KVFX4					
94	KVFX3					
95	KVFX2					
96	KVFX1					
97	KVFX0					
98	KVFX3					
99	KVFX2					
100	KVFX1					
101	GEARB					
102	KVB3					
103	KVB2					
104	KVB1					
105	KVB0					
106	KIFX2					
107	KIFX1					
108	KIFY1					
109	KIFY0					
110	KIB1					
111	KIB0					
112	SAMPLE1					
113	SAMPLE2					
114	SAMPLE3					
115	SAMPLE4					
116	REC_CNT					
117	FNC_OUT					
118	FF_OUT					
119	VB_OUT					
120	V_EXT					Velocity of external encoder (Pulse In) in counts per sample
121	VF_OUT					
122	ANINP					
123	ANINP_OFFSET					
124	ELDEGN_OFFSET					
125	ELDEGP_OFFSET					
126	PHASE_COMP					
127	AMPLITUDE					
128	MAN_I_NOM					
129	MAN_ALPHA					
130	UMEAS					
131	I_NOM					
132	PHI_SOLL					
133	IA_SOLL					
134	IB_SOLL					
135	IC_SOLL					
136	IX_SELECT					
137	IA_IST					
138	IB_IST					
139	IC_IST					
140	IA_OFFSET					
141	IB_OFFSET					
142	IC_OFFSET					

T11525GB

# 5.12

# Internal registers

Only MAC50 - I4I

Reg. Nr.	Firmware / MacRegIo Name	MacTalk Name	Range / Default	Size / Access	Unit	Description
143	ELDEG_IST					
144	V_ELDEG					
145	UA_VAL					
146	UB_VAL					
147	UC_VAL					
148	KIA					
149	KIB					
150	KIC					
151	U_SUPPLY					
152	MIN_U_SUP					
153	MOTORTYPE					
154	SERIALNUMBER, 32-bit					
155	(hi-word of SERIALNUMBER)					
156	MYADDR					
157	HWVERSION					
158	CHECKSUM, 32-bit					
159	(hi-word of CHECKSUM)					
160	UV_HANDLE					Bit 0, SET_UV_ERR Bit 1, UV_GO_PASSIVE Bit 2, unused Bit 3, UV_VSOLL0
161	INV_OUTPUT					Bit 0, INV_INPOSOUT Bit 1, INV_ERROROUT Bit 2, INVROTDIR Bit 3, O1USERCTRL Bit 4, O2USERCTRL
162	INDEX_OFFSET					
163	P_NEW, 32-bit					
164	(hi-word of P_NEW)					
165	FILTERID, 32-bit					
166	(hi-word of FILTERID)					
167	HARDWARELIM					Bit 0, HW_PLIM_NEG Bit 1, HW_PLIM_POS Bit 2, HW_PLIM_IN1 Bit 3, HW_PLIM_IN2 Bit 4, HW_PLIM_IN3 Bit 5, HW_PLIM_IN4 Bit 6, HW_PLIM_IN5 Bit 7, HW_PLIM_IN6 Bit 8, HW_PLIM_ANINP
168	HOMING_DONE					Bit-0 set every time a zero search has completed. Not cleared by firmware, except after reset.

T11526GB

## 5.12

## Internal registers

Only MAC50 - I4I

Reg. Nr.	Firmware / MacRegIo Name	MacTalk Name	Range / Default	Size / Access	Unit	Description
169	GROUP_ID					
170	GROUP_SEQ					
171	MONITOR_CMP					
172	MONITOR_REG1					
173	MONITOR_REG2					
174	MONITOR_ACT					
175	MONITOR_SRC					
176	MONITOR_DST					
177	MONITOR_SAV					
178	SSI_BITS1					Bit 0, SSI_ENABLE Bit 1, SSI_DIR Bit 2, SSI_POS_SYNC Bit 3, SSI_RESET Bit 4, SSI_NOCHECK Bit 15, SSI_ERROR_CNTL
179	OUTPUT_CTRL					Bit 0, OUTPUT_O1 Bit 1, OUTPUT_O2
180	SETUP_BITS					Bit 0, POWERSAVE_ENABLED
181	V_IST_MAX					
182	UART1_SETUP		0, 1, 2			Selects what protocol to run on the RS422 lines that can be used for Pulse In, Pulse Out or Serial Data. The selection in this register is used only if the lowest two bits in Reg36, CNTRL_BITS are set to Serial Data.  Values of Reg182, UART1_SETUP:  0: Autodetect incoming 1 Megabit Modbus telegrams for a few seconds after startup. Stay in Modbus if any valid Modbus telegrams detected, else switch to 19200 baud FastMac and stay in Fastmac.  1: Run the FastMac protocol at 19200 baud from the beginning and stay in FastMac.  2-65535: Run 1 Megabit/s Modbus from the beginning and stay in Modbus.
183	STATUS_BITS					
184	MODE0 / M1					
185	MODE1 / M2					
186	MODE2 / M3					
187	MODE3 / M4					
188	HWI0, 32-bit					
189	(hi-word of HWI0)					
190	HWI1, 32-bit					
191	(hi-word of HWI1)					
192	HWI2, 32-bit					
193	(hi-word of HWI2)					
194	HWI3, 32-bit					
195	(hi-word of HWI3)					
196	HWI4, 32-bit					
197	(hi-word of HWI4)					

T1527GB

## 5.12

## Internal registers

Only MAC50 - I4I

Reg. Nr.	Firmware / MacReglo Name	MacTalk Name	Range / Default	Size / Access	Unit	Description
198	HWI5, 32-bit					
199	(hi-word of HWI5)					
200	HWI6, 32-bit					
201	(hi-word of HWI6)					
202	HWI7, 32-bit					
203	(hi-word of HWI7)					
204	-					Reserved for future purposes
205	-					Reserved for future purposes
206	-					Reserved for future purposes
207	-					Reserved for future purposes
208	-					Reserved for future purposes
209	-					Reserved for future purposes
210	-					Reserved for future purposes
211	COMMAND					
212	FIELDDBUS_ADDR					
213	FIELDDBUS_SPEED					
214	-					Reserved for future purposes
215	-					Reserved for future purposes
216	-					Reserved for future purposes
217	-					Reserved for future purposes
218	-					Reserved for future purposes
219	-					Reserved for future purposes
220	-					Reserved for future purposes
221	-					Reserved for future purposes
222	-					Reserved for future purposes
223	-					Reserved for future purposes
224	-					Reserved for future purposes
225	-					Reserved for future purposes
226	-					Reserved for future purposes
227	-					Reserved for future purposes
228	-					Reserved for future purposes
229	-					Reserved for future purposes
230	-					Reserved for future purposes
231	-					Reserved for future purposes
232	-					Reserved for future purposes
233	-					Reserved for future purposes
234	-					Reserved for future purposes
235	-					Reserved for future purposes
236	-					Reserved for future purposes
237	-					Reserved for future purposes
238	-					Reserved for future purposes
239	-					Reserved for future purposes
240	-					Reserved for future purposes
241	-					Reserved for future purposes
242	-					Reserved for future purposes
243	-					Reserved for future purposes
244	-					Reserved for future purposes
245	-					Reserved for future purposes
246	-					Reserved for future purposes
247	-					Reserved for future purposes
248	-					Reserved for future purposes
249	-					Reserved for future purposes
250	-					Reserved for future purposes
251	-					Reserved for future purposes
252	-					Reserved for future purposes
253	-					Reserved for future purposes
254	-					Reserved for future purposes

TI1528GB



## 5.12

## Internal registers

Only MAC400 to 3000

### 5.12.3 MAC400, 402, 800, 1500 and 3000 register list.

The following list is only valid for the MAC400, MAC402, MAC800, MAC1500 and MAC3000 motors.

The list is valid from firmware version **2.07** or newer.

Reg. Nr.	Firmware / MacReglo Name	MacTalk Name	Range / Default	Size / Access	Unit	Description
0	N/A	N/A	N/A	N/A	N/A	Dummy register, do not use.
1	PROG_VERSION	Displayed on bottom right status line.	-	- / R	-	Firmware version
2	MODE_REG	Startup mode / Change actual mode	0..25, 256, 257, 258 / 0 (passive)	Word / RW	-	<p>The actual operating mode of the drive.</p> <p>In general, the motor will either be passive, attempt to reach a certain position, attempt to maintain a constant velocity or attempt to produce a constant torque. The various modes define the main type of operation as well as what determines the setpoint for that operation.</p> <p>The special cases 256..258 are used to perform a few special operations on the entire set of registers.</p> <p>Supported values are:            0 = <b>Passive mode</b>. The axis is not controlled by the drive, and can easily be moved by hand or external mechanics.            1 = <b>Velocity mode</b>. The drive will attempt to run the motor at a constant velocity selected by Reg5, V_SOLL, without violating the maximum torque or acceleration.            2 = <b>Position mode</b>. The drive will at all times attempt to move the actual motor position to the position selected by Reg3, P_SOLL, without violating the maximum velocity, torque or acceleration.            3 = Gear Position mode.            4 = Analogue torque mode.            5 = Analogue velocity mode.            6 = Analog Velocity Gear mode.            7 = Manual current mode.            8 = Step response test mode.            9 = Internal test mode.            10 = Brake mode.            11 = Stop mode.            12 = Torque based zero search mode.            13 = Forward/only zero search mode.            14 = Forward+backward zero search mode.            15 = Safe mode.            16 = Analogue velocity with deadband mode.            17 = Velocity limited Analog Torque mode.            18 = Analogue gear mode.            19 = Coil mode.            20 = Analogue bi-position mode.            21 = Analogue to position mode.            22 = Internal test mode.            23 = Internal test mode.            24 = Gear follow mode.            25 = IHOME mode.            256:            257:            258:</p>

# 5.12

# Internal registers

Only MAC400 to 3000

Reg. Nr.	Firmware / MacReglo Name	MacTalk Name	Range/ Default	Size / Access	Unit	Description
3	P_SOLL	Max Velocity	..	Word / RW	Encoder counts	The target position that the drive will attempt to reach in position related modes.
4	P_NEW	<i>(not present)</i>	$\pm 2^{31}$ / 0	Word / RW	Encoder counts	Used to update both P_IST and P_SOLL in a single atomic operation to prevent motor movements during the change. P_NEW holds either an absolute position or a relative position. After writing a value to P_NEW, update both bits 8 and 6 in Reg36, CNTRL_BITS. Bit 8, SYNCPOSREL, will select a relative position update when set or an absolute update when cleared. Setting bit 6, SYNCPOSMAN, executes the P_IST+P_SOLL update, that is, either both are set equal to P_NEW, or P_NEW is added to both, using signed addition. P_FUNC is updated accordingly. The undocumented FastMac commands 23 and 24 can also be used to set these bits and perform the same absolute and relative updates. This is useful for expanding the logical position range beyond +/- 2 <sup>31</sup> .
5	V_SOLL	Max Velocity	Na / 277(100RPM)	Word / RW	..	Desired velocity 1 RPM=2.77056 counts/sample. Example: To obtain 100 RPM, V_SOLL must be set to 277.
6	A_SOLL	Acceleration	na / 18	Word / RW	Cnt's/ Sample <sup>2</sup>	The desired nominal acceleration. 1000 RPM/s = 3.598133 counts/Sample <sup>2</sup> Example: To obtain 100000 RPM/s, A_SOLL must be set to 360.
7	T_SOLL	Torque	0-1023 / 1023(300%)	Word / RW	-	The maximum torque that the drive is allowed to use. The value 1023 corresponds to 300% of nominal load, and is the absolute maximum peak torque allowed. The value 341 gives 100% (nominal load).
8	P_FUNC			Word / RW	Encoder counts	
9	INDEX_OFFSET	<i>(not present)</i>		Word / RW	Encoder counts	Updated after a Zero Search to show at what single-turn encoder position the zero point was detected. This is used by MacTalk on the Test tab to show if the zero search resulted in a valid zero position.
10	P_IST	Actual Position	$\pm 2^{31}$ / 0	Word / RW	Encoder counts	The actual motor position measured by the internal encoder. Updated every 1.3ms (or every 2.6 ms with Reg157, OUTLOPDIV=2) Note that this register is maintained incrementally, which means that the user can update it to offset the working range. When updating when the drive is not in Passive mode, P_IST and P_SOLL should be updated together in an atomic operation, using Reg4, P_NEW, or other special measures. Also note that the firmware will change this register after a zero search operation has completed.
11	V_IST_16	Actual Velocity	Na / 0	Word / R	Enc.cnt's/ Sample/16	V_IST (actual velocity) measured over 16 samples. Same unit as V_SOLL (register 5).
12	V_IST	<i>(not present)</i>	Na / 0	Word / R	Enc.cnt's/ Sample	Actual velocity. 1RPM=0.17316 counts/sample.
13	KVOUT	Load	Na / 65536(1.0)	Fixed16 / RW	-	Must be set to the ratio between the total inertia driven by the motor relative to the motors own rotor inertia. So for at motor shaft that is not mechanically connected to anything, this value should be 1.0. The load factor is perhaps the single most important value of the filter setup. Always try to set this right before experimenting with filter setups.

TI1501GB

# 5.12

# Internal registers

Only MAC400 to 3000

Reg. Nr.	Firmware / MacRegIo Name	MacTalk Name	Range/ Default	Size / Access	Unit	Description
14	GEARF1	Gear factor Input	Na / 2000	Word / RW	-	The nominator used to scale / gear pulses from an external encoder/source. Used in gear modes.
15	GEARF2	Gear Output	Na / 500	Word / RW	-	The denominator used to scale / gear pulses from an external encoder/source. Used in gear modes.
16	I2T	Motor Load (mean)	Na / 0	Word / R	-	The calculated power dissipated in the motor, and thus an approximated value for the rise in temperature inside the physical motor. See also I2TLIM (Reg 17). MacTalk value is calculated as $[\%]=I2T/I2TLIM \times 100$
17	I2TLIM	(not present)	Na / 100000	Word / R	-	The limit for the value of Reg16, I2T, where bit 0, I2T_ERR, in Reg35, ERR_STAT will be set and the motor will change into passive mode.
18	UIT	Regenerative Load	Na / 0	Word / R	-	The calculated power dissipated in the internal power dump/brake resistors, and thus a way to estimate their rise in temperature. See also UITLIM (Reg 19) MacTalk value is calculated as $[\%]=UIT/UITLIM \times 100$
19	UITLIM	(not present)	Na / 2322	Word / R	-	The limit for the value of Reg18, UIT, where bit 3, UIT_ERR, in Reg35, ERR_STAT will be set and the motor will change into passive mode.
20	FLWERR		Na / 0	Word / RW	Encoder counts	A measure of how far the drive is from its ideal regulation goal. This value is calculated differently in the various modes, and can mean things like 'pulses from theoretical position' or 'difference in actual velocity to V_SOLL'. Contact JVL for more detailed information for specific modes.
21	U_24V		Na / 0	Word / R		The internal control voltage measured.
22	FLWERRMAX		Na / 0	Word / RW	Encoder counts	When Reg20, FLWERR, exceeds this limit, bit 1, FLW_ERR, in Reg35, ERR_STAT, is set and the motor will stop if Reg22 is non-zero. Usually this value is set experimentally to detect situations where a movement is blocked or fails.
23	UV_HANDLE	- Set error bit - Go to passive - Set velocity to 0	Na / 0	Word / RW		Bits to determine what will happen when the main supply voltage to the motor is below the threshold for motor operation. Any combination of the following bits can be set. Bit 0: Set bit 9, UV_ERR, in Reg35, ERR_STAT. Bit 1: Perform a controlled stop, then go passive. Bit 2: Set V_SOLL to zero, do not go passive.
24	FNCERR	(not present)	Na / 0	Word / RW	Encoder counts	Shows how much the motor is behind the ideal movement; precise operation depends on mode. When this accumulated value exceeds Reg26, FNCERRMAX, the FNC_ERR bit is set in Reg35, ERR_STAT and the motor will stop.
25	P_IST_TURNTAB	(not present)	Na / 0	Word / R	-	Displays the actual position, like P_IST, but is offset by N times the rotary table working range so P_IST_TURNTAB is always between MIN_P_IST and MAX_P_IST. Used mainly with the Rotary table option.
26	FNCERRMAX	(not present)	Na / 0	Word / RW	Encoder counts	The limit used with Reg24, FNCERR.
27	TURNTAB_COUNT	(not present)	Na / 0	Word / RW	-	Holds a count of the number of times the value of Reg25, P_IST, wraps around one of its limits, MIN_P_IST or MAX_P_IST. Used only with the Rotary table option. Counts up or down depending on the direction of the wrap around.
28	MIN_P_IST	(not present)	Na / 0	Word / RW	Encoder counts	Used to define and enable the minimum software position limit, so the motor will stop (and enter passive mode) if the value of P_IST (the actual position) gets below this value. If MIN_P_IST is zero, the low position limit will not be enabled.
29	DEGC	(not present)	Na / 0	Word / R	-	The temperature measured inside the drive.

TT1502GB

# 5.12

# Internal registers

Only MAC400 to 3000

Reg. Nr.	Firmware / MacRegIo Name	MacTalk Name	Range/ Default	Size / Access	Unit	Description
30	MAX_P_IST	<i>(not present)</i>	Na / 0	Word / RW	Encoder counts	Used to define and enable the maximum software position limit, so the motor will stop (and enter passive mode) if the value of P_IST (the actual position) gets above this value. If MAX_P_IST is zero, the high position limit will not be enabled. In Rotary Table operation, this limit is used as the higher wrap-around position count.
31	DEGCMAX	<i>(not present)</i>	Na / 690(84°C)	Word / R	-	The maximum value of Reg29, DEGCMAX, before the motor will set the Temperature error bit in ERR_STAT and change into Passive mode. Same scaling as Reg29, DEGCMAX.
32	ACC_EMERG	<i>(not present)</i>	Na / 0	Word / RW	-	Acceleration to use during emergency stops.
33	INPOSWIN	<i>(not present)</i>	Na / 100	Word / RW	Encoder counts	<p>The value of this parameter depends on the operating mode. In all cases it helps to define when the motor is InPosition and thus will set the InPosition bit in the ERR_STAT register.</p> <p>For normal Position related modes, the motor is considered to be in position when the actual position is less than INPOSWIN encoder counts away from its target position P_SOLL and have been detected to be so at least INPOSCNT times.</p> <p>For Velocity related modes, the concept of InPosition will instead mean AtVelocity and work in a similar way that the actual velocity V_IST must have been measured INPOSCNT consecutive times to be within INPOSWIN counts/sample before the InPosition bit is set in Reg35, ERR_STAT.</p>
34	INPOSCNT	<i>(not present)</i>	Na / 3	Word / RW	-	The number of consecutive times the In Position condition must have been met before the InPosition bit is set in ERR_STAT. See description above for INPOSWIN.
35	ERR_STAT	<i>(not present)</i>	Na / 0	Word / RW	-	<p>Bit 0, I2T_ERR Set when the calculated thermal energy stored in the physical motor exceeds a limit. Condition is that Reg16, I2T gets larger than Reg17, I2TLIM.</p> <p>Bit 1, FLW_ERR Set if the follow error in Reg20, FLWERR, gets larger than Reg22, FLWERRMAX. Never set if Reg22, FLWERRMAX is zero.</p> <p>Bit 2, FNC_ERR Set if the function error in Reg24, FNCERR, get slarger than Reg26, FNCERRMAX. Never set if Reg26, FNCERRMAX is zero.</p> <p>Bit 3, UIT_ERR Set when the calculated energy/temperature in the internal brake resistor (power dump) get dangerousl high.</p> <p>Bit 4, IN_POS In Position mode, status of when/whether the motor position is inside the inposition window defined by RegReg33, INPOSWIN, for the number of samples defined in Reg34, INPOSCNT. In Velocity mode, this bit means rather 'At Velocity'. For other modes, like Torque modes, see the technical manual for details of how the inposition status is calculated/maintained.</p> <p>Bit 5, ACC_FLAG Set when the motor is accelerating, which means that the velocity changes from a higher value to a lower value over tah latest samples. Please note that, when the velocity is negative, this flag is set when the velocity changes from a more negative value to a less negative value (closer to zero). This may not be intuitive, but can be said to be mathematically correct, and is maintained for backwards compatibility reasons.</p>

TH503GB

# 5.12

# Internal registers

Only MAC400 to 3000

Reg. Nr.	Firmware / MacRegIo Name	MacTalk Name	Range/ Default	Size / Access	Unit	Description
35	ERR_STAT	(not present)	Na / 0	Word / RW	-	<p><b>Bit 6, DEC_FLAG</b> Set when the motor is decelerating. Please see the description for ACC_FLAG above to understand the behaviour with negative velocity.</p> <p><b>Bit 7 PLIM_ERR</b> Set when one of the software position limits in Reg28 and Reg30 have been exceeded. Note that there is an option to temporarily disable position limits to be able to be move inside the position limit range again.</p> <p><b>Bit 8, DEGC_ERR</b> Temperature error; set when the value in Reg29, DEGC, exceeds the value in Reg31, DEGCMAX.</p> <p><b>Bit 9, UV_ERR</b> Under voltage error; can be set when either the AC sense detects missing 230 or 120 V AC input, or when the DC bus voltage get below a threshold voltage of approximately 80 V DC. Note that this error will only get set if bit 0 in Reg23, UV_HANDLE, is set. The AC sense input is not used with MAC402.</p> <p><b>Bit 10, UV_DETECT</b> Reflects the current status of missing AC input or low DC bus voltage, on the same condition as UV_ERR above. The bit will be cleared when the under voltage condition is no longer present for about one second. Note that there is a hysteresis built-in, so the DC bus voltage must be 1.25 times higher than the cut-off voltage threshold before the under voltage condition is cleared.</p> <p><b>Bit 11, OV_ERR</b> Overvoltage error; gets set when the DC bus voltage is measured to be above 450 V for MAC400 and MAC800, or 1000 V DC for MAC1500 and MAC3000, or 54 V DC for MAC402. Overvoltage often comes when the motor is braking a large inertia and the internal or external power dump/brake resistor can no longer accumulate the energy. It can also come from connecting a too high AC or DC supply voltage, perhaps by connecting 230VAC to the 120 VAC input on MAC400.</p> <p><b>Bit 12, IPEAK_ERR</b> A much too high current was measured in one or more of the motor phases. This can happen if the supply voltage is too low relative to the rotational speed. It can also happen in more extreme short-time overload conditions. This error requires a reset or power cycling of the drive since it cannot be cleared using the normal Clear Errors mechanisms.</p> <p><b>Bit 13, SPEED_ERR</b> The velocity was measured to be higher than a limit for an average of 16 samples. This limit is normally 3600 RPM for MAC800, MAC1500 and MAC3000, and it is 4300 RPM for MAC400 and MAC402. There is an option in later firmware to increase the speed error limit to 4000 RPM on MAC800 for shorter movements.</p> <p><b>Bit 14, DIS_P_LIM</b> This bit is not an error or status bit, but rather a command bit. When this is set, the motor will stay in an active mode and allow moves even though one of the software position limits defined by Reg28 and Reg30 is exceeded. The bit is automatically cleared once the position gets inside the valid position range.</p> <p><b>Bit 15, INDEX_ERR</b> The bit is set if an encoder error is detected. This can be a real encoder hardware error or excessive electrical noise. The motor must be reset or power cycled to clear this error.</p> <p><b>Bit 16, OLDFILTERR</b> This bit is no longer used. It could detect if a previous version of the velocity filters was found, or loaded, that did not work with newer firmware.</p>

TI1533-01GB

# 5.12

# Internal registers

Only MAC400 to 3000

Reg. Nr.	Firmware / MacRegIo Name	MacTalk Name	Range/ Default	Size / Access	Unit	Description
35	ERR_STAT	(not present)	Na / 0	Word / RW	-	<p><b>Bit 17, U24V_ERR</b> This error bit get set if the control voltage, normally at 24VDC, is measured to be below 12 V (9V on MAC402). The motor must be reset or power cycled to clear this error. It is considered unsafe to continue, because the electronics may not work correctly, and may have lost data.</p> <p><b>Bit 18, SHORT_CIRC</b> This bit is not used with the 400 Watts or higher motors.</p> <p><b>Bit 19, VAC_ON</b> Reflects the status of detection of the mains AC input (230 or 120 VAC). This bit is set when AC is detected and cleared when AC is not detected. The motor will refuse to enter an active mode if it detects that AC is not present. It will refuse to activate the power dump/brake resistor if it determines that this bit is set.</p> <p><b>Bit 20, PWM_LOCKED</b> A critical error has occurred that makes further motor operation too unsafe to continue. The motor must be reset to clear this error. The cause of this error is one or more of bits IPEAK_ERR, INDEX_ERR, OLDFILTER, U24V_ERR. At least one of these bits will be set when PWM_LOCKED is set.</p> <p><b>Bit 21, COMM_ERR</b> Communications error (master or slave timeout with Modbus-Gear mode).</p> <p><b>Bit 22, CURLOOP_ERR</b> Less than 2 mA was detected on the 4-20 mA input on the MAC00-P4/P5 module for more than 100 ms</p> <p><b>Bit 23, SLAVE_ERR</b> One or more error bits were set in an ERR_STAT reading from the Modbus slave or COMM_ERR</p> <p><b>Bit 24, ANY_ERR</b> single bit to make easier on PLCs to chekfc if the motor has any error bits set. Reflect the logical operation of: (ERR_STAT and ALL_ERROR_BITS) different from zero)</p> <p><b>Bit 25, INIT_ERR:</b> Set if error was detected during motor startup that could prevent reliable operation. This includes mainly that the shaft moved at the time the encoder Hall information was read, so there is a great risk that the motor will start with an uncontrolled movement and possibly go into error. This bit can also catch some types of internal misconfigurations, like hardware version checks, mainly to help JVL production employees.</p> <p><b>Bit 26, FLASH_ERR</b> An error was detected related to the internal flash memory during startup. In most cases, this is related to the use of the multi-turn absolute encoder value saved in flash at power down, and restored during power up.</p> <p><b>Bit 27, STO_ALARM_ERR</b> This bit gets set if the supervisor circuitry of the Safe Torque Off (STO) system detects an error. This will normally indicate an error in the electronics.</p> <p><b>Bits 28, 29:</b> Unused so far. (firmware v2.06, July 2013)</p> <p><b>Bit 30, OUT1_STATUS</b> Status of the physical pin normally used for the IN_POSITION signal/hardware output. The pin can also be used for user defined purposes and this bit will reflects its state also in this case.</p> <p><b>Bit 31, OUT2_STATUS</b> Status of the physical pin normally used for the ERROR_OUT signal/hardware output. The pin can also be used for user defined purposes and this bit will reflects its state also in this case.</p>

TI1534-01GB

# 5.12

# Internal registers

Only MAC400 to 3000

Reg. Nr.	Firmware / MacRegIo Name	MacTalk Name	Range/ Default	Size / Access	Unit	Description
36	CNTRL_BITS	(not present)	Na / 32	Word / RW	-	<p><b>Bit 0, RECORDBIT</b> Set by the user to start or continue the sampling of register values, using the Classic scope system. This bit will clear itself when the sample buffer has been filled.</p> <p><b>Bit 1, REWINDBIT</b> If set, the index into the sample buffer will be zeroed and sampling will continue if in progress. This bit is typically set together with RECORD_BIT above.</p> <p><b>Bit 2, RECINNERBIT</b> If set, the samplinG7scope system samples at 100 microseconds between samples instead of the normal 1.3milliseconds. Normally used only for internal JVL development and service purposes.</p> <p><b>Bit 3, RELPOSPSOLL</b> <b>Bit 4, RELPOSPFNC</b> These two bits select what happens if one of the general-purpose position registers, P1 through P8 is 'activated' by a FastMac command. If one of these is set, this activates a relative movement rather than the absolute position move that happens if none of these bits are set. If RELPOSPSOLL is set alone, the value of the selected P1-P8 register is added to the target position register Reg3, P_SOLL.</p> <p>If RELPOSPFNC is set, the value of the selected P1-P8 is added to an internal variable that will generate the movement, leaving P_SOLL unchanged. This is used for 'endless relative' movements, since it will not cause any overflow of the target position, but note that the actual position will wrap around at <math>\pm 2^{31}</math> (2,147,483,648 counts) without problems for the movement.</p> <p>Note that these bits also control the movements in Analogue Bi-position mode in similar ways.</p> <p><b>Bit 5, SYNCPOSAUTO</b> If set when switching mode from Passive mode into an active mode, The follow error and the function error are zeroed, and the actual position is transferred to the P_FNC register, to avoid initial movement.</p> <p><b>Bit 6, SYNCPOSMAN</b> Set to manually synchronize the position by copying the value of P_NEW, to P_IST, P_SOLL, and P_FNC, with proper scaling. In other words, set:  <math>P\_IST = P\_NEW,</math>  <math>P\_SOLL = P\_NEW,</math>  <math>P\_FNC = (P\_NEW + FLWERR)*16.</math>                      See also bit 8 below.                      Note that this operation is performed as an atomic (unbreakable) operation, and is currently the only way to perform this perfect synchronization.</p> <p><b>Bit 7, MAN_NO_BRAKE</b></p> <p><b>Bit 8, SYNCPOSREL</b> When set, modifies the manual synchronization performed by bit 6 above to use relative synchronization rather than absolute synchronization. In other words, set:  <math>P\_IST = P\_IST + P\_NEW,</math>  <math>P\_SOLL = P\_SOLL + P\_NEW,</math>  <math>P\_FNC = P\_FNC + (P\_NEW + FLWERR)*16.</math></p>

TI1504GB

Reg. Nr.	Firmware / MacReglo Name	MacTalk Name	Range/ Default	Size / Access	Unit	Description
36	CNTRL_BITS	<i>(not present)</i>	Na / 32	Word / RW	-	(Continued) Bit 9, INDEX_HOME Bit10, FWTRIGBITS When set, use the advanced sampling with firmware trigger conditions - when 0, use backwards compatible sampling Bit 11, SAMPLING_BIT Set when sampling is active after trigger has been detected Bit 12, TRIGGER_ARMED_BIT Set when sampling is active but trigger has not been detected yet Bit 13, ADVSAMPLE_BIT If set, enables div-shift, min/max/avg + bitfield sampling.
37	START_MODE	<i>(not present but is preset as function of the mode register)</i>	Na / 0	Word / RW	-	Determines in what mode the motor should start after power on and after a Zero Search. This register works closely together with Reg2, MODE_REG.  Bits [31:16] are reserved. Bits [15:8] are used to select the type of zero search to perform when the FastMac command (16 + 96) is received. This should be one of 12, 13, 14, or zero. Bits [7:0] select the value to transfer to Reg2, MODE_REG at motor power up and after a zero search has completed.  If bits [15:8] are non-zero the motor will remain in Passive mode at power up regardless of the value in bits [7:0]. The intention is then to wait for a FastMac command 16 + 96. It is also possible to simply write a new value to Reg2, MODE_REG to change mode.
38	P_HOME	Zero search position	Na / -10000	Word / RW	Encoder counts	The offset value to use to adjust P_IST at the end of a Zero Search.
39	HW_SETUP	<i>(not present)</i>	Na / 9	Word / RW	-	Bit 0, DIRAWR Bit 1, DIRBWR Bit 2, PULSEOUT Bit 3, XSEL1 Bit 4, XPRINP Pulse/Direction or Quadrature input type. Bit 5, NOFILT Disable lowpass filtering of external encoder pulses. Bit 6, INVXDIR Bit 7, INVROTDIR Bit 8, USER_INPOS Bit 9, USER_ERROR Error output pin is controlled by the user via RegXX Bit 10, INV_INPOS_OUT Bit 11, INV_ERROR_OUT Bit 12, CMP_ERROR_OUT If set, OUT2_PIN is controlled by (P_IST > CMP_POS0) (continued next page)



## 5.12

## Internal registers

Only MAC400 to 3000

Reg. Nr.	Firmware / MacReglo Name	MacTalk Name	Range/ Default	Size / Access	Unit	Description
39	HW_SETUP (continued from last page)	(not present)	Na / 9	Word / RW	-	<p>Bit 13, PULSE_8000 If set, rescale the 8192 encoder pulses to 8000 for MAC800 compatibility and better Vel-filter performance Bits 14..15: reserved Bit 16, DIRCDWR Direction signal for the MultiFunclo2 A channel (or both A and B?) Bit 17, SELINDEX Not used - prepared to select between encoder A or Index signal -&gt; MultF. Bit 18, ALWAYS_COOL Bit 19, POSITION_CAPTURE_UP Used to enable SW position capture based on analogue input rising edge Bit 20, POSITION_CAPTURE_DN Used to enable SW position capture based on analogue input falling edge Bit 21, PULSE_8000 If set, rescale the 8192 encoder pulses to 8000 for MAC800 compatibility and better Vel-filter performance Bit 22, ENC_SCALING Reserved for freely selectable encoder scaling. Bit 23, SBUF_2048 Set to use a sample buffer length of 2048. Use 512 if not set (backwards compatible).</p>
40	V_HOME	(not present)	Na / -138	Word / RW	-	Velocity to use during a zero search operation (Homing operation). After the operation has completed, the drive will go back to using the regular V_SOLL.
41	T_HOME	(not present)	Na / 341	Word / RW	-	Torque to use during a zero search operation (Homing operation). After the operation has completed, the drive will go back to using the regular T_SOLL.
42	HOME_MODE	(not present)	Na / 0	Word / RW	-	<p>Defines if the motor should start a zero search immediately after start up, as well as the type of zero search to perform when a FastMac command is received. Bits 7..0 define the zero search mode the motor should start up in. If this value is zero, the motor will not perform a zero search at startup, but will start up in the mode selected by Reg37, START_MODE. See bits 15..8 below for an exception! Bits 15..8 define what mode the motor will set when it receives a FastMac command (96+16). NOTE that if all these bits are non-zero the motor will start up in passive mode instead of starting in START_MODE! Bit 16 is set after a zero search has completed, and can thus be used to test if the motor has performed a zero search at least once after +24V was last turned on. After a zero search has completed, the motor will always change into the mode defined by Reg 37, START_MODE (unless an error occurs that will stop the motor and set ERR_STAT bit(s)).</p>
43	P_REG_P	(not present)	0-8 / 0	Word / RW	-	When set to 1..8, copies one of POS0..POS7 to P_SOLL, then resets to 0
44	V_REG_P	(not present)	0-8 / 0	Word / RW	-	When set to 1..8, copies one of VEL0..VEL7 to V_SOLL, then resets to 0
45	A_REG_P	(not present)	0-4 / 0	Word / RW	-	When set to 1..4, copies one of ACC0..ACC3 to A_SOLL, then resets to 0
46	T_REG_P	(not present)	0-4 / 0	Word / RW	-	When set to 1..4, copies one of TQ0..TQ3 to T_SOLL, then resets to 0
47	L_REG_P	(not present)	0-4 / 0	Word / RW	-	When set to 1..4, copies one of LOAD0..LOAD3 to KVOUT then resets to 0
48	Z_REG_P	(not present)	0-4 / 0	Word / RW	-	When set to 1..4, copies one of ZERO0..ZERO3 to INPOSWIN, then resets to 0

TI1505GE

# 5.12

# Internal registers

Only MAC400 to 3000

Reg. Nr.	Firmware / MacReglo Name	MacTalk Name	Range/ Default	Size / Access	Unit	Description
49	POS0	Position1 (P1)	Na / 0	Word / RW	-	
50	CAPCOM0	<i>(not present)</i>	Na / 0	Word / RW	-	
51	POS1	Position2 (P2)	Na / 0	Word / RW	-	
52	CAPCOM1	<i>(not present)</i>	Na / 0	Word / RW	-	
53	POS2	Position3 (P3)	Na / 0	Word / RW	-	
54	CAPCOM2	<i>(not present)</i>	Na / 0	Word / RW	-	
55	POS3	Position4 (P4)	Na / 0	Word / RW	-	
56	CAPCOM3	<i>(not present)</i>	Na / 0	Word / RW	-	
57	POS4	Position5 (P5)	Na / 0	Word / RW	-	
58	CAPCOM4	<i>(not present)</i>	Na / 0	Word / RW	-	
59	POS5	Position6 (P6)	Na / 0	Word / RW	-	
60	CAPCOM5	<i>(not present)</i>	Na / 0	Word / RW	-	
61	POS6	Position7 (P7)	Na / 0	Word / RW	-	
62	CAPCOM6	<i>(not present)</i>	Na / 0	Word / RW	-	
63	POS7	Position8 (P8)	Na / 0	Word / RW	-	
64	CAPCOM7	<i>(not present)</i>	Na / 0	Word / RW	-	
65	VEL0	Velocity 1 (V1)	Na / 277(100RPM)	Word / RW	-	Velocity register V1. Used with the fastmac protocol or by the MAC00-R1/3/4 nanoPLC module. See also V_SOLL (register 5) which have the same scaling.
66	VEL1	Velocity 2 (V2)	Na / 277(100RPM)	Word / RW	-	Velocity register V8 - see also register 65.
67	VEL2	Velocity 3 (V3)	Na / 277(100RPM)	Word / RW	-	Velocity register V8 - see also register 65.
68	VEL3	Velocity 4 (V4)	Na / 277(100RPM)	Word / RW	-	Velocity register V8 - see also register 65.
69	VEL4	Velocity 5 (V5)	Na / 277(100RPM)	Word / RW	-	Velocity register V8 - see also register 65.
70	VEL5	Velocity 6 (V6)	Na / 277(100RPM)	Word / RW	-	Velocity register V8 - see also register 65.
71	VEL6	Velocity 7 (V7)	Na / 277(100RPM)	Word / RW	-	Velocity register V8 - see also register 65.
72	VEL7	Velocity 8 (V8)	Na / 277(100RPM)	Word / RW	-	Velocity register V8 - see also register 65.

TI1506GB

# 5.12

# Internal registers

Only MAC400 to 3000

Reg. Nr.	Firmware / MacRegIo Name	MacTalk Name	Range/ Default	Size / Access	Unit	Description
73	ACC0	<i>(not present)</i>	Na / 18(5003RPM/s²)	Word / RW	Enc.cnt's Per sample²	
74	ACC1	<i>(not present)</i>	Na / 18(5003RPM/s²)	Word / RW	Enc.cnt's Per sample²	
75	ACC2	<i>(not present)</i>	Na / 18(5003RPM/s²)	Word / RW	Enc.cnt's Per sample²	
76	ACC3	<i>(not present)</i>	Na / 18(5003RPM/s²)	Word / RW	Enc.cnt's Per sample²	
77	TQ0	Torque 1 (T1)	Na / 1023(300%)	Word / RW		Torque register T1. Used with the fastmac protocol or by the MAC00-R1/3/4 nanoPLC module. See also T_SOLL (register 7)
78	TQ1	Torque 2 (T2)	Na / 1023(300%)	Word / RW	-	Torque register T2 - see also register 77.
79	TQ2	Torque 3 (T3)	Na / 1023(300%)	Word / RW	-	Torque register T2 - see also register 77.
80	TQ3	Torque 4 (T4)	Na / 1023(300%)	Word / RW	-	Torque register T2 - see also register 77.
81	LOAD0	Load 1 (L1)	Na / 0	Word / RW	-	
82	LOAD1	Load 2 (L2)	Na / 0	Word / RW	-	
83	LOAD2	Load 3 (L3)	Na / 0	Word / RW	-	
84	LOAD3	Load 4 (L4)	Na / 0	Word / RW	-	
85	ZERO0	<i>(not present)</i>	Na / 0	Word / RW	-	
86	ZERO1	<i>(not present)</i>	Na / 0	Word / RW	-	
87	ZERO2	<i>(not present)</i>	Na / 0	Word / RW	-	
88	ZERO3	<i>(not present)</i>	Na / 0	Word / RW	-	
89	MODE0	<i>(not present)</i>	Na / 0	Word / RW	-	
90	MODE1	<i>(not present)</i>	Na / 0	Word / RW	-	
91	MODE2	<i>(not present)</i>	Na / 0	Word / RW	-	
92	MODE3	<i>(not present)</i>	Na / 0	Word / RW	-	
93	HWI0	<i>(not present)</i>	Na / 0	Word / RW	-	<p><b>HardWare Inputs Regs 93-104, HWI0-11, allow the digital inputs from Reg106 to control the values of other motor registers.</b></p> <p>The most common use is to copy one of two values to a target register. This can be used to switch between two velocities, positions or modes. For instance to switch between two target positions, set Reg49, POS0 to 1000 and Reg51, POS1 to 2000 and set the motor into position mode. Then P_SOLL can be set to receive either the value 1000 or 2000 depending on the voltage on the digital input (the Input State)</p> <p>The copying is executed every 1.3 ms. The digital inputs can thus be considered level-triggered rather than edge-triggered. (Continued next page)</p>

TI1507GE

Reg. Nr.	Firmware / MacReglo Name	MacTalk Name	Range/ Default	Size / Access	Unit	Description
93	HWI0 (Continued from last page)	(not present)	Na / 0	Word / RW	-	<p>Each of the HWI0-11 registers have the following bit fields:  Bits [31:24]: Destination register used (only) when bits [3:0] equals 7.  Bits [23:16]: Source register number 0..254 for DI=1  Bits [15:8]: Source register number 0..254 for DI=0  Bits [7:4]: Select digital input bit number in Reg106.  Bits [3:0]: Target register selection. 0=None, 1=MODE_REG, 2=V_SOLL, 3=P_SOLL, 4=A_SOLL, 5=T_SOLL, 6=INPOSWIN, 7=Register number from bits [31:24].</p> <p>When the value of bits [3:0] are one of 1..6, the two source registers are implicitly fixed to the corresponding group of register, and the value of bits [23:16] and bits [15:8] are used as an index into that group of registers. For instance if bits [3:0] equals 3, the values of bits [23:16] and bits [15:8] must be in the range 1..8 to select POS1..POS8 for source registers to copy into P_SOLL.  When the value of bits [3:0] equals 7, the values of bits [23:16] and [15:8] hold the full register numbers in the range 1-254.</p> <p>For more advanced use, any of the source register or index values can be set to zero, which means DoNothing. This effectively means that in one of the Input States a source register will be copied to the target register, while in the other Input State no copying will happen so the target register will not be modified by the digital input.</p> <p>The 12 HWI functions are executed every 1.3 ms in the order from HWI0 to HWI11. NO other operations happen in between regardless of communications and other parallel operations. It is therefore safe to rely on stable register values and consistent digital input values during the execution of the 12 HWI functions. This implies that HWI function with higher numbers have higher priority because they are executed later, and that it is safe to change the same target register several times during the HWI evaluation.</p> <p>Note that each of the HWI function can use any of the digital inputs, and that more than one HWI function can use the same digital input.</p> <p>A typical HWI application is Jogging, where two pushbuttons connected to two separate digital inputs are used to move the motor position manually. This can be realized with a HWI setup like:  HWI0 uses Digital Input 1:  ON =&gt; MODE_REG=1 (velocity mode)  OFF =&gt; MODE_REG=3 (gear mode)</p> <p>HWI1 also uses Digital Input 1:  ON =&gt; V_SOLL=+100RPM  OFF =&gt; V_SOLL = 3000 RPM</p> <p>HWI2 uses Digital Input 2:  ON =&gt; MODE_REG=1 (velocity mode)  OFF =&gt; MODE_REG=3 (gear mode)</p> <p>HWI3 also uses Digital Input 2:  ON =&gt; V_SOLL=-100RPM  OFF =&gt; V_SOLL = 3000 RPM</p> <p>This will keep the motor in Gear mode with a maximum velocity of 3000 RM when none of the pushbuttons are activated, and change to Velocity mode wit either +100 or -100 RPM as long as one of the pushbuttons are held active. In this setup Digital Input 2 will have higher priority than Digital Input 1, because it is evaluated later and overwrites V_SOLL in case both buttons are held down.</p>

## 5.12

## Internal registers

Only MAC400 to 3000

Reg. Nr.	Firmware / MacRegIo Name	MacTalk Name	Range/ Default	Size / Access	Unit	Description
94	HWI1	<i>(not present)</i>	Na / 0	Word / RW	-	See Reg93, HWI0, for description
95	HWI2	<i>(not present)</i>	Na / 0	Word / RW	-	See Reg93, HWI0, for description
96	HWI3	<i>(not present)</i>	Na / 0	Word / RW	-	See Reg93, HWI0, for description
97	HWI4	<i>(not present)</i>	Na / 0	Word / RW	-	See Reg93, HWI0, for description
98	HWI5	<i>(not present)</i>	Na / 0	Word / RW	-	See Reg93, HWI0, for description
99	HWI6	<i>(not present)</i>	Na / 0	Word / RW	-	See Reg93, HWI0, for description
100	HWI7	<i>(not present)</i>	Na / 0	Word / RW	-	See Reg93, HWI0, for description
101	HWI8	<i>(not present)</i>	Na / 0	Word / RW	-	See Reg93, HWI0, for description
102	HWI9	<i>(not present)</i>	Na / 0	Word / RW	-	See Reg93, HWI0, for description
103	HWI10	<i>(not present)</i>	Na / 0	Word / RW	-	See Reg93, HWI0, for description
104	HWI11	<i>(not present)</i>	Na / 0	Word / RW	-	See Reg93, HWI0, for description
105	MAC00_TYPE	<i>(not present)</i>	Na / 0	Word / RW	-	Identifies the Generation-2 module type autodetected at startup. 0 = No Gen2 module found, 1=MAC00-B41, 2=MAC00-P4 or MAC00-P5 found.
106	MAC00_1 / Digital Inputs	I/O management	Na / 0	Word / RW	-	<p>The registers from 106 to 120 are used to support different interface modules with the Generation-2 connectors. The function of these registers will be different depending on which module is mounted in the motor. The Gen.2 module type is detected automatically by the motor at start up. Reg106, Digital inputs, is a bitmapped value where bits [15:8] show the status of hardware signals in the basic motor as described below, while bits [7:0] show the status of the digital inputs from the MAC00-B41 module.</p> <p>Be aware that bits [15:0] in Reg215, IO_POLARITY, can be set to invert the value of the corresponding bits [15:0] in this register.</p> <p>Bits [15:12] show the values of the four RS-422 signals. These are intended mostly for serial communications to some modules or to use Modbus RS485, but they can be used as digital inputs provided that the input voltage is kept within -7 to +12 volts. These are differential signals, so to use them as single-ended inputs, one of the differential lines must be kept at a constant voltage in between the high and low thresholds for the single-ended line.</p> <p>At the time of this writing, bits [15:12] are supported on MAC400, but not yet on MAC800.</p> <p>Bit 15: Multifunction 1, channel B            Bit 14: Multifunction 1, channel A            Bit 13: Multifunction 2, channel B            Bit 12: Multifunction 2, channel A</p> <p>Bits [10:8] show the status of the analogue inputs ANINP2, ANINP1 and ANINP. Status will be high (logic 1) when the value of the analogue line is above 5.0 volts. This threshold can be adjusted by modifying the corresponding ANINPx_OFFSET registers. This way it is possible to use the analogue inputs as digital inputs with adjustable thresholds in the range -10V to +10V.</p> <p>Bit 10: ANINP2 (not signal conditioned)            Bit 9: ANINP1 (not signal conditioned)            Bit 8: ANINP (signal conditioned)</p> <p>To use ANINP3 (available on the MAC00-P4 and MAC00-P5 modules as analogue current loop 4-20 mA) use Reg222, IOSETUP to make ANINP reflect the (signal conditioned) value of this input, so the digital status will be shown in Bit 8. To use ANINP2 as a signal conditioned input, use a similar trick so IOSETUP is set to make ANINP reflect the signal conditioned value of ANINP2 in bit 8.</p> <p>Bits 6, 7, and 11 are unused.</p>

# 5.12

# Internal registers

Only MAC400 to 3000

Reg. Nr.	Firmware / MacRegIo Name	MacTalk Name	Range/ Default	Size / Access	Unit	Description
107	MAC00_2	(not present)	Na / 0	Word / RW	-	Shows various status bits for the currently mounted Gen2 module.  For the MAC00-B41:  Bit 0: Digital Output overload. This shows the status of the output driver chip that controls the six digital outputs. The overload status can be set if either an overcurrent condition or a too high temperature is detected. This status bit is cleared when these conditions are no longer present.  Bit 1: CVO voltage detected. This bit reflects if the voltage at the CVO terminal is above a hardwired default value. CVO is the supply voltage for the digital outputs.
108	MAC00_3	(not present)	Na / 0	Word / RW	-	N/U
109	MAC00_4	(not present)	Na / 0	Word / RW	-	N/U
110	MAC00_5	(not present)	Na / 0	Word / RW	-	N/U
111	MAC00_6	(not present)	Na / 0	Word / RW	-	N/U
112	MAC00_7	(not present)	Na / 0	Word / RW	-	N/U
113	MAC00_8 / B41_DO / Digital outputs	I/O management	Na / 0	Word / RW	-	Bits [5:0] of this register controls the digital outputs O6..O1 on the MAC00-B41 module. Each bit that is set here will enable the corresponding PNP output.  It is possible to overwrite these bits by using Registers 115-120, see below.  Also Reg215, IO_POLARITY, will invert the value of these bits before there are written to the hardware.
114	MAC00_9 / B41_DOSTATUS	I/O management	Na / 0	Word / RW	-	Shows the status of each of the six digital outputs actually written to the hardware.  This value will be Reg113, possibly modified by Regs115-120 and finally possibly having some bits inverted by Reg215.
115	MAC00_10 / B41_CONF0	(not present)	Na / 0	Word / RW	-	Controls <b>IO1</b> on MAC00-B41 (bit 0 in B41_DO).  Each of the B41_CONF5..CONF0 registers can be used to modify the corresponding digital outputs by effectively overwriting bits [5:0] in Reg113, B41_DO.  They can be set to replace the corresponding bit in B41_DO with any bit from any motor register in the range 1..254, typically status bits from Reg35, ERR_STAT, for instance bits INPOS or ANY_ERR.  Bits [31:24]: reserved Bits [23:16]: Source register number, 1..254. Bits [15:5]: Reserved Bits [4:0]: Bit number in source register to use.  Reg215, IO_POLARITY, will be applied after these registers to allow general inversion of each digital output bit.
116	MAC00_11 / B41_CONF1	(not present)	Na / 0	Word / RW	-	Controls <b>IO2</b> on MAC00-B41 (bit 1 in B41_DO). See Reg115, B41_CONF0 for description.
117	MAC00_12 / B41_CONF2	(not present)	Na / 0	Word / RW	-	Controls <b>IO3</b> on MAC00-B41 (bit 2 in B41_DO). See Reg115, B41_CONF0 for description.
118	MAC00_13 / B41_CONF3	(not present)	Na / 0	Word / RW	-	Controls <b>IO4</b> on MAC00-B41 (bit 3 in B41_DO). See Reg115, B41_CONF0 for description.
119	MAC00_14 / B41_CONF4	(not present)	Na / 0	Word / RW	-	Controls <b>IO5</b> on MAC00-B41 (bit 4 in B41_DO). See Reg115, B41_CONF0 for description.
120	MAC00_15 / B41_CONF5	(not present)	Na / 0	Word / RW	-	Controls <b>IO6</b> on MAC00-B41 (bit 5 in B41_DO). See Reg115, B41_CONF0 for description.

TT1510GE

# 5.12

# Internal registers

Only MAC400 to 3000

Reg. Nr.	Firmware / MacReglo Name	MacTalk Name	Range/ Default	Size / Access	Unit	Description
121	KFF5	KFF5	Na / 0	Word / RW	-	Filter coefficients used by the velocity and position regulator loops. These values should be loaded only from MacTalk, and not modified by the user, since this can have dangerous effects.
122	KFF4	KFF4	Na / 0	Word / RW	-	
123	KFF3	KFF3	Na / 0	Word / RW	-	
124	KFF2	KFF2	Na / 0	Word / RW	-	
125	KFF1	KFF1	Na / 0	Word / RW	-	
126	KFF0	KFF0	Na / 0	Word / RW	-	
127	KVFX6	(not present)	Na / 0	Word / RW	-	
128	KVFX5	(not present)	Na / 0	Word / RW	-	
129	KVFX4	(not present)	Na / 0	Word / RW	-	
130	KVFX3	(not present)	Na / 0	Word / RW	-	
131	KVFX2	(not present)	Na / 0	Word / RW	-	
132	KVFX1	(not present)	Na / 0	Word / RW	-	
133	KVFX0	(not present)	Na / 0	Word / RW	-	
134	KVFX1	(not present)	Na / 0	Word / RW	-	
135	KVFX2	(not present)	Na / 0	Word / RW	-	
136	KVFX3	(not present)	Na / 0	Word / RW	-	
137	KVFX4	(not present)	Na / 0	Word / RW	-	
138	KVFX5	(not present)	Na / 0	Word / RW	-	
139	KVFX6	(not present)	Na / 0	Word / RW	-	
140	KVFX7	(not present)	Na / 0	Word / RW	-	
141	KVFX8	(not present)	Na / 0	Word / RW	-	
142	KVFX9	(not present)	Na / 0	Word / RW	-	
143	KVFX10	(not present)	Na / 0	Word / RW	-	
144	KIFX2	(not present)	Na / 0	Word / R	Filter coefficients used by the current loop for low-level control of the phase currents. These values are fixed and should not be modified by the user.	
145	KIFX1	(not present)	Na / 0	Word / R		
146	KIFY1	(not present)	Na / 0	Word / R		
147	KIFY0	(not present)	Na / 0	Word / R		
148	KIB1	(not present)	Na / 0	Word / R		
149	KIB0	(not present)	Na / 0	Word / R		

## 5.12

## Internal registers

Only MAC400 to 3000

Reg. Nr.	Firmware / MacReglo Name	MacTalk Name	Range/ Default	Size / Access	Unit	Description
150	<reserved>	(not present)	-			
151	<reserved>	(not present)	-			
152	<reserved>	(not present)	-			
153	<reserved>	(not present)	-			
154	<reserved>	(not present)	-			
155	ID_RESERVED	(not present)	-			<reserved>
156	S_ORDER	(not present)	Na / 0	Word / RW	-	<p>An S-profile can be used to modify/smooth the acceleration at the beginning and end of a change in velocity. This is useful to prevent overshoot.</p> <p>The value of zero disables the S-profile so the normal A_SOLL is used. Values 1..8 can be used to select a progressively smoother S-profile, with 8 being the smoothest (and slowest).</p> <p>The value of S_ORDER may not be changed unless the motor is in Passive mode (MODE_REG=0).</p>
157	OUTLOOPDIV	(not present)	Na / 0	Word / RW	-	<p>Divider value for the velocity loop. With the standard value of 1, the velocity loop is recalculated every 1.3 ms. With a value of 2, the loop is recalculated every 2.6 ms, which can give better performance for slow movements and/or large inertia.</p> <p>It is absolutely necessary to use a different set of filters in Regs121-142 when changing this value.</p> <p>To change this value from MacTalk, and gain access to the extended filters, open the Filter Setup window, then hold down both the Control and Shift keys and double-click on the text 'More' to the left of the 'Stability' slider (at the green end). After entering the correct password, Sample Frequency can be selected and MacTalk will use the appropriate filter set. Note that the units of all velocity-related register, measured in counts/sample will now be doubled, and all acceleration-related registers, measured in Counts/sample<sup>2</sup>, will be four times larger.</p>

TI1512GB



## 5.12

## Internal registers

Only MAC400 to 3000

Reg. Nr.	Firmware / MacRegIo Name	MacTalk Name	Range/ Default	Size / Access	Unit	Description
158	SAMPLE1	(not present)	Na / 0	Word / RW	-	SAMPLE1..4 controls the scope/sample function.  Register number, bit field and min/max/average sample type for the first value in each sample.
159	SAMPLE2	(not present)	Na / 0	Word / RW	-	Register number, bit field and min/max/average sample type for the second value in each sample.
160	SAMPLE3	(not present)	Na / 0	Word / RW	-	Register number, bit field and min/max/average sample type for the third value in each sample.
161	SAMPLE4	(not present)	Na / 0	Word / RW	-	Register number, bit field and min/max/average sample type for the fourth value in each sample.
162	REC_CNT	(not present)	0-511 or 0..2047 / 0	Word / RW	-	Index into the sample buffer used for scope functionality. The length of the sample buffer, and thus the range of this parameter if determined by bit 23, SBUF_2048, in Reg39, HW_SETUP. See document/section "YY" for further information on the sample system.
163	V_EXT	(not present)	Na / 0	Word / R	-	Unscaled/Raw velocity of external encoder input in pulses per 1.3ms.
164	GV_EXT	(not present)	Na / 0	Word / R	-	Velocity of external encoder input V_EXT, after being scaled by the ratio GEARF1/GEARF2
165	G_FNC	(not present)	Na / 0	Word / R	-	
166	FNC_OUT	(not present)	Na / 0	Word / R	-	
167	FF_OUT	(not present)	Na / 0	Word / R	-	
168	VB_OUT	(not present)	Na / 0	Word / R	-	
169	VF_OUT	Actual torque	Na / 0	Word / RW	-	
170	ANINP	(not present)	Na / 0	Word / RW	-	
171	ANINP_OFFSET	(not present)	Na / 0	Word / RW	-	
172	ELDEG_OFFSET	(not present)	Na / 0	Word / R	-	<used with motor current loop>
173	PHASE_COMP	(not present)	Na / 0	Word / R	-	<used with motor current loop>
174	AMPLITUDE	(not present)	Na / 0	Word / R	-	<used with motor current loop>
175	MAN_I_NOM	(not present)	Na / 0	Word / RW	-	<used with motor current loop>
176	MAN_ALPHA	(not present)	Na / 0	Word / RW	-	<used with motor current loop>
177	UMEAS	(not present)	Na / 0	Word / R	-	<used with motor current loop>
178	I_NOM	(not present)	Na / 0	Word / R	-	<used with motor current loop>
179	PHI_SOLL	(not present)	Na / 0	Word / R	-	<used with motor current loop>
180	IA_SOLL	(not present)	Na / 0	Word / R	-	<used with motor current loop>
181	IB_SOLL	(not present)	Na / 0	Word / R	-	<used with motor current loop>
182	IC_SOLL	(not present)	Na / 0	Word / R	-	<used with motor current loop>

TI1513GB

## 5.12

## Internal registers

Only MAC400 to 3000

Reg. Nr.	Firmware / MacReglo Name	MacTalk Name	Range/ Default	Size / Access	Unit	Description
183	IA_IST	<i>(not present)</i>	Na / 0	Word / R	-	<used with motor current loop>
184	IB_IST	<i>(not present)</i>	Na / 0	Word / R	-	<used with motor current loop>
185	IC_IST	<i>(not present)</i>	Na / 0	Word / R	-	<used with motor current loop>
186	IA_OFFSET	<i>(not present)</i>	Na / 0	Word / R	-	<used with motor current loop>
187	IB_OFFSET	<i>(not present)</i>	Na / 0	Word / R	-	<used with motor current loop>
188	KIA	<i>(not present)</i>	Na / 0	Word / R	-	<used with motor current loop>
189	KIB	<i>(not present)</i>	Na / 0	Word / R	-	<used with motor current loop>
190	ELDEG_IST	<i>(not present)</i>	Na / 0	Word / R	-	<used with motor current loop>
191	V_ELDEG	<i>(not present)</i>	Na / 0	Word / R	-	<used with motor current loop>
192	UA_VAL	<i>(not present)</i>	Na / 0	Word / R	-	<used with motor current loop>
193	UB_VAL	<i>(not present)</i>	Na / 0	Word / R	-	<used with motor current loop>
194	UC_VAL	<i>(not present)</i>	Na / 0	Word / R	-	<used with motor current loop>
195	EMK_A	<i>(not present)</i>	Na / 0	Word / R	-	<used with motor current loop>
196	EMK_B	<i>(not present)</i>	Na / 0	Word / R	-	<used with motor current loop>
197	EMK_C	<i>(not present)</i>	Na / 0	Word / R	-	<used with motor current loop>
198	U_BUS	Bus voltage	Na / 0	Word / R	-	The actual voltage of the internal DC bus, updated every 100 us. One count corresponds to -0.888V.
199	U_BUS_OFFSET	<i>(not present)</i>	-	Word / R	-	Factory offset used to calibrate the measurement of Reg198, U_BUS.
200	TC0_CV1	<i>(not present)</i>	Na / 0	Word / R	-	<used by JVL only to monitor internal timing>
201	TC0_CV2	<i>(not present)</i>	Na / 0	Word / R	-	<used by JVL only to monitor internal timing>

TI1514GB

## 5.12

## Internal registers

Only MAC400 to 3000

Reg. Nr.	Firmware / MacReglo Name	MacTalk Name	Range/ Default	Size / Access	Unit	Description
202	MY_ADDR	(not present)	Na / 0	Word / RW	-	The motor address used for the MacTalk protocol. The motor will respond to telegrams with this address or the broadcast address 255.  MY_ADDR can also be used for the Modbus protocol if selected in Reg213, UART1_SETUP:  Further, MY_ADDR can be read and used by the fieldbus modules for CANopen, DeviceNet and Profibus to define their address on the fieldbus, if not selected by DIP-switches on the MAC00-xx module.
203	MOTOR_TYPE	(not present)	Na / 0	Word / R	-	Value read from factory flash memory to identify the type of motor: 12=MAC400, 13=MAC400B, 14=MAC800, 15=MAC800B.
204	SERIAL_NUMBER	(not present)	Na / 0	Word / R	-	Value read from factory flash memory to show the JVL serial number of the motor.
205	HW_VERSION	(not present)	Na / 0	Word / R	-	Bits [23:20]: Value read from factory flash memory to identify the Main version of the bootloader. Bits [19:16]: Value read from factory flash memory to identify the Minor version of the bootloader.  Bits [7:4]: Value read from factory flash memory to identify the Main version of the PCB controller board hardware. Bits [3:0]: Value read from factory flash memory to identify the Minor version of the PCB controller board hardware.  The remaining bits are reserved.
206	CHKSUM	(not present)	Na / 0	Word / R	-	Value read from factory flash memory to show the checksums of the firmware and the bootloader.
207	USEROUTVAL	(not present)	Na / 0	Word / RW	-	The values of bits [1:0] are output to the standard InPosition and ErrorOut hardware signals if the corresponding bits [9:8], USER_INPOS and USER_ERROR, in Reg39, HW_SETUP are set.
208	COMM_ERRS	(not present)	Na / 0	Word / RW	-	Counts the number of communication errors that have occurred on the MacTalk serial interface. Errors can be framing errors and protocol data errors.
209	INDEX_IST	(not present)	0..8191 or 0..7999	Word / R	-	Actual single-turn position of the internal encoder, valid for both incremental and absolute encoders.
210	HW_PLIM	(not present)	Na / 0	Word / RW	-	Hardware position limits – used by the MAC00-FSx module.
211	COMMAND_REG	(not present)	Na / 0	Word / RW	-	1=Reset, 2=Save to flash and reset, 128..255 = Execute FastMac commands.
212	UART0_SETUP	MacTalk Baudrate	Na / 0	Word / RW	-	0=9600, 1=19200, 2=38400, 3=57600, 4=115200, 5=230400 baud.
213	UART1_SETUP	Serial data	Na / 0	Word / RW	-	This register selects the type of protocol to use on the Serial Data interface. See section "XX".
214	EXTENC_BITS	(not present)	Na / 0	Word / RW	-	Supports setup of signals used for label dispenser functionality with the MAC00-B41 module.
215	INPUT_LEVELS	(not present)	Na / 0	Word / RW	-	
216	ANINP1	(not present)	Na / 0	Word / RW	-	
217	ANINP1_OFFSET	(not present)	Na / 0	Word / RW	-	
218	ANINP2	(not present)	Na / 0	Word / RW	-	
219	ANINP2_OFFSET	(not present)	Na / 0	Word / RW	-	
220	ANINP3	(not present)	Na / 0	Word / RW	-	
221	ANINP3_OFFSET	(not present)	Na / 0	Word / RW	-	

TM515GE

## 5.12

## Internal registers

Only MAC400 to 3000

Reg. Nr.	Firmware / MacRegIo Name	MacTalk Name	Range/ Default	Size / Access	Unit	Description
222	IOSETUP	<i>(not present)</i>	Na / 0	Word / RW	-	Selects what hardware analogue input signal that goes to the main ANINP register and controls some filtering/signal conditioning.
223	ANOUT1	<i>(not present)</i>	Na / 0	Word / RW	-	The value written here by the user, or by the firmware, will be output to the 4-20 mA hardware output on the MAC00-P5/P4 modules.
224	ANOUT1_OFFSET	<i>(not present)</i>	Na / 0	Word / RW	-	Offset that is added to ANOUT1 before writing to hardware.
225	P_OFFSET	<i>(not present)</i>	Na / 0	Word / RW	-	Used to adjust the zero position for absolute multi-turn encoders.
226	P_MULTITURN	<i>(not present)</i>	Na / 0	Word / RW	-	The full multi-turn position read directly from the absolute encoder, if mounted.
227	AIFILT_MAXSLOPE	<i>(not present)</i>	Na / 0	Word / RW	-	
228	AIFILT_FILTERFACT	<i>(not present)</i>	Na / 0	Word / RW	-	
229	P_QUICK	N/A	Na / 0	Word / RW	-	The actual position of the internal encoder. Much like P_IST, but updated every 100us. P_IST is updated only once every 1.3ms (or 2.6 ms for OUTLOOPDIV=2).
230	XREG_ADDR	<i>(not present)</i>	Na / 0	Word / RW	-	Address of extended registers, XREGs. A positive value will write the contents of Reg231, XREG_DATA, to that register. A negative value will cause the value of that XREG to be written to XREG_DATA. After the reading or writing operation has completed, XREG_ADDR will be set to zero. The first NN XREGs are used for configuration of the switchboard for hardware signals that can be routed in several ways through the FPGA in MAC800 HW 1.8 and later or MAC400 HW1.? And later.
231	XREG_DATA	<i>(not present)</i>	Na / 0	Word / RW	-	Data to or from extended registers. See XREG_ADDR for description

TT1516GE

## 5.13 Connecting to other equipment

### 5.13.1 Connecting the MAC motor to a Jetter PLC type Nano-B/C/D

In many applications a PLC is used as the central “intelligence”. To adapt the MAC motor in such types of applications, an axis module on the PLC is often used. The illustration below shows how to connect the MAC motor with a Jetter PLC type Nano-B/C/D equipped with a servo axis controller module JX2-SV1.

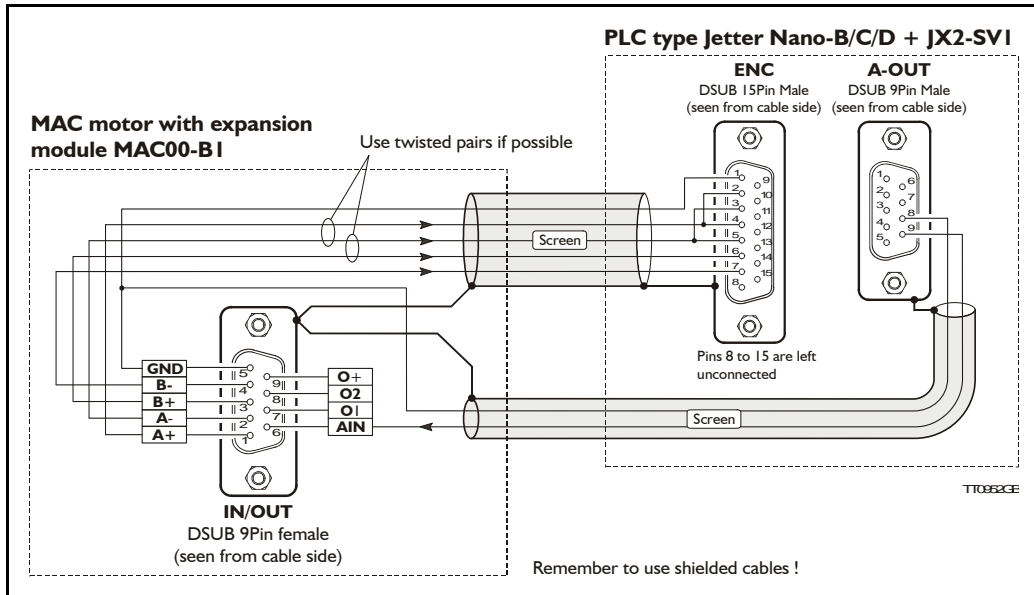

Connection scheme:

MAC motor IN/OUT 9-pole connector (MAC00-B1)	Jetter JX2-SV1 9-pole connector	Jetter JX2-SV1 15-pole connector
Pin 1		Pin 2 + 4
Pin 2		Pin 3 + 5
Pin 3		Pin 6
Pin 4		Pin 7
Pin 5	Pin 8	Pin 1
Pin 6	Pin 9	

The illustration can also be used as a common diagram for other PLC manufacturers since the fundamental principle is to feed an analogue control voltage from the axis module to the MAC motor dictating the speed or torque. The MAC motor returns the internal encoder signal back to the PLC module in order to let the PLC know what the actual velocity and/or position is.

#### Standard cables:

If the MAC00-B4 expansion module with M12 connectors is used, JVL can offer a standard cable type WI0040. This cable connects directly between the MAC00-B4 module and the Jetter JX2-SV1.

## 5.13 Connecting to other equipment

### 5.13.2 How to set up the MAC motor for the JX2-SV1

The following illustration shows how to set up the MAC motor. Remember to select the “Save in flash” button after the setup is done in order to save the changes permanently.

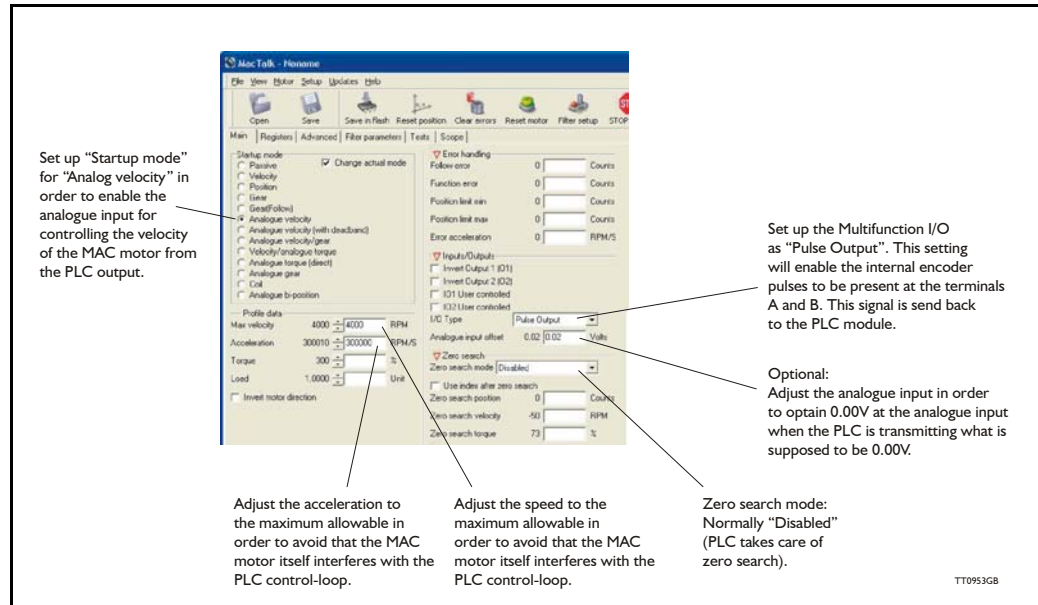

### 5.13.3 Setup in Jetter JX2-SV1 - Mode 2

Set up the registers as follows (when the SV1 module is placed as the first intelligent module after the CPU, i.e. module no. = 2, meaning registers are numbered I2Ixx):

- I2I98 = 2 ; Mode (0...3)
- I2I17 = 1024 ; Encoder lines
- I2I18 = 2000 ; Max. speed in RPM which the MAC + SV1 combination can reach.  
; This value will depend on the supply voltage. Please consult the  
; description *Power supply (only MAC050 to 141)*, page 87.
- I2I21 = 2000 ; Example - ref. value for setpoint speed in register I2I03.
- I2I03 = 1000 ; Example - meaning 100.0% of maximum speed, i.e. 2000 RPM.

Adjust the following register values when commissioning the servo solution:

- I2I16 = xxx ; Offset value for the analogue output. The MAC motor should not drift  
; and at nominal position 0 (zero), R12102, the SV1 must be able to  
; to control the axis very close to actual position 0, R12109.
- I2I10 = yyy ; P-gain.

Please also follow the instructions in the JX2-SV1 user manual.

**Remark:** If the MAC motor is supplied by 24VDC, the setup for the MAC motor must be 3000 RPM - even though the MAC itself is not allowed to run more than 2000 RPM at this voltage. Do not worry, the SV1 module controls and limits the speed correctly. See also *Power supply (only MAC050 to 141)*, page 87.

## 5.13 Connecting to other equipment

### 5.13.4 Setup in Jetter JX2-SV1 - Mode 3

Same as for mode 2 but the MAC motor must be set up in “Analogue torque direct”.  
Set up the mode register: 12198 = 3; Mode (0...3)  
See also - *Setup in Jetter JX2-SV1 - Mode 2, page 413* - for set up of other SV1 registers.

Adjust the registers for Digital Speed Control:

- 12124 = xxx ; Proportional gain (speed).
- 12126 = xxx ; Integral gain.
- 12127 = xxx ; Current limitation, a value of 2047 corresponds to 10.0V.
- 12128 = xxx ; Present integral gain.
- 12129 = xxx ; Limitation of the integral gain.

Please also follow the instructions in the JX2-SV1 user manual.

### 5.13.5 Connect the MAC motor to Jetter PLC with JX2-SM2 axis module

The Jetter PLC can be supplied with the module JX2-SM2 which transmits a pulse and direction signal instead of a +/-10V signal as on the JX2-SV1 module. Each pulse represents a certain distance of movement and the direction signal determines the direction.  
Connection scheme:

MAC motor IN/OUT 9-pole connector (MAC00-B1)		Jetter JX2-SM2 9-pole connector	
Pin 1	A+	Pin 1	STEP+
Pin 2	A-	Pin 6	STEP-
Pin 3	B+	Pin 2	DIR+
Pin 4	B-	Pin 7	DIR-
Pin 5	GND	Pin 4 + 9	GND

All 4 dip-switches on the rear side of the MAC00-B1 module must be switched to position “off”.

### 5.13.6 How to set up the MAC motor for the JX2-SM2

The following illustration shows how to set up the MAC motor. Remember to select the “Save in flash” button after the setup is done in order to save the changes permanently.

Set up “Startup mode” for “Gear” in order to enable the pulse and direction input for controlling the position of the MAC motor via the pulse and direction signal.

Set up the gear-ratio to 1024 for input and output.

Adjust the acceleration to the maximum allowable in order to avoid that the MAC motor itself interferes with the PLC control-loop.

Adjust the speed to the maximum allowable in order to avoid that the MAC motor itself interferes with the PLC control-loop.

Zero search mode: Normally “Disabled” (PLC takes care of zero search).

Set up the Multifunction I/O as “Pulse Input”. This setting will setup the Multifunction I/O as 2 balanced inputs. The A input will be the pulse input and the B input will be the direction input.

Choose “Pulse-Direction” format.

TT0955GB

The following accessories are available for the MAC motor series.

### 5.14.1 Cables

#### **RS232-9-1**

Setup and communication cable. Length 3 m

Standard RS232 cable that is used for connecting MAC motors with an integrated expansion module to a standard computer serial COM port.

The following expansion modules include an RS232 COM port based on a 9-pole DSUB connector which matches the RS232-9-1:

MAC00-B1

MAC00-R1

#### **RS232-9-1-MAC**

Setup and communication cable. Length 3 m.

Setup and communication cable used for the BASIC MAC motor which is NOT equipped with a full RS232 interface. The cable can be used between the BASIC MAC motor and a standard RS232 COM port.

#### **WG0302 (2m) or WG0320 (20m)**

Power cable with 2 x 0.75mm<sup>2</sup> inner wires + screen. The colour is black.

The cable is fitted with a Molex connector at one end. The other end is open.

This cable can be used together with the following units.

MAC50 to 141 Fits directly to the 2-pole power connector inside the basic MAC motor.

MAC00-CS Passes through the -CS module and connects to the basic MAC motor.

MAC00-R3 Passes through the -R3 module and connects to the basic MAC motor.

Optional : If the Molex connector is cut off, the cables can also be used for:

MAC00-B2 Connects to the 3-pole screw terminal named "power".

MAC00-FP2 Connects to the 2-pole screw terminal named "power".

#### **WG0402 (2m) or WG0420 (20m)**

I/O cable with 12 twisted pairs (24 wires)+ screen. The colour is black. The cable is fitted at one end with - 1 pcs. 6-pole connector, 1 pcs. 8-pole connector and 1 pcs. 10-pole connector. The other end is open.

The cable can be used with following units.

MAC00-FP2 Connects inside to all the I/Os +RS232 interface. Only the power and profibus connections are not covered by this cable.

MAC00-R3 Connects inside to all the I/Os +RS232/RS485 interface.

#### **WG0502 (2m) or WG0520 (20m)**

I/O cable for the basic MAC motors. The cable has 4 twisted pairs (8 wires)+ screen.

The colour is black. The cable is fitted with an AMP connector at one end which fits the 8-pole I/O connector inside the basic MAC motor. The other end is open.

The cable can be used with following units.

MAC50 to 141 Fits directly to the 8-pole I/O connector inside the basic MAC motor.

MAC00-CS Passes through the -CS module and connects to the basic MAC motor.



## 5.14

## Accessories

---

### 5.14.2 Connectors / connector kits

#### MAC00-CONKIT I

This kit contains all 3 connectors for the Basic Mac Motor.

Power connector:	JVL no. 3069-02 JVL no. 2478-TL	Housing 2p. Pitch 3.96mm (Molex no. 09-91-0200). Crimp contacts (Molex no. 08-50-0106).
RS232 Connector:	JVL no. WG0200	Since this connector is very small (pitch= 1.5mm), it is supplied as an assembled connector with 65mm cable. WG0200 is the JVL number.
I/O Connector:	JVL no. 254H08 JVL no. 4809C-P914L	Housing 8p. Pitch 2.54mm (AMP no. 770602-8) Crimp contacts (AMP no. 770601-1)

By ordering this connector kit, all of the above-mentioned parts are included. Please ensure that a proper crimp tool is used when the contacts are fitted. The type numbers mentioned in brackets are the original type numbers from either Molex or AMP.

### 5.14.3 Power Supplies

#### PSU00-PDI

Combined power dump, resistor, and capacitor unit. For a complete power supply system, only a transformer with a secondary winding supplying 32VAC is required.

For systems with up to 5-8 MAC motors, this unit can serve as a central power dump unit.

The capacitor offers an efficient and economical way of storing the energy returned from the motors during deceleration of high inertias. See also [www.jvl.dk](http://www.jvl.dk)

#### PSU48-240

A compact switch-mode power supply with 240W output power at 48VDC.

The power supply is UL and CSA approved. It is protected against overvoltage, overtemperature and short-circuit or overload of the output. The power supply can either be mounted on a DIN rail or "wall" mounted. See also the data-sheet LD0047-xx which can be downloaded at [www.jvl.dk](http://www.jvl.dk)

#### Other power supplies:

JVL offers a wide range of power supplies in the power range 45W up to 1.5kW with the output voltages 24 and 48VDC. They all use switch-mode technology in order to minimize physical dimensions and for easy adaptation to mains voltages in the range 90 to 240VAC.

The product range covers the following types: PSU05-045, PSU24-075, PSU24-240, PSU48-240, PSU48-800, PSU48-1000, PSU48-1500.

See also the data-sheet LD0058 (overview) or LD0053 (detailed) which can be downloaded at [www.jvl.dk](http://www.jvl.dk).

### 5.14.4 Brakes and shaft reinforcement

2 brake units are available for the MAC50-141 motors. The MAB23x-01 offers 10mm output shaft and MAB23x-02 offers 6.35mm output shaft. Both types can be mounted directly on all the MAC50-141 motors and require 24VDC applied to release the motor. No brakes are available for the MAC400 and 800 since they are constructed with an integrated brake which is a part of the order number for the complete motor.

See also the data-sheet LD0055-xx which can be downloaded at [www.jvl.dk](http://www.jvl.dk).

# 5.15

# Cable drawings

## 5.15.1 WI1000-M12F5T05N - M12 Power cable 5 pin female

M12. 5 PIN FEMALE CONNECTOR

J1

TYPE: WI1000-M12F5T05N

LENGTH = 5 M

TEXT PRINTED ON GREEN TUBE

VIEW FROM FRONT

COLOR	SIGNAL NAME	PIN NO. J1
SCREEN		HOUSING
BROWN	P+	1
WHITE	P+	2
BLUE	P-	3
BLACK	(OPTIONS)	4
GREY	P-	5

LT0233-10

<p>JVL INDUSTRI ELEKTRONIK A/S BLOKKEN 42 • DK-3460 BIRKERØD TEL: +45 4582 4440 FAX: +45 4582 5550</p>	<p>WI1000-M12F5T05N M12 shl cable 5 m 5 pin Fem 0° Power</p>	VERSION - 1.0	DATE: 04-07-13	
		APPROVED BY: - BVJ	DRAWN BY: PCR	

## 5.15.2 WI1028-M8M3ST005 - Safety stop cable.

1 3 4

All Screen shall be connected to the connector house

Length = 5000mm

PVC shield and Screen

Foil shield

Pin 1

Pin 3

Brown

Black

J1

M8 socket, 3 pin, male

Cable data:  
Approvals: UL 94V0  
2xAWG28 with screen  
on both wire and a  
outside screen as well

LT0239-12

<p>JVL Industri Elektronik A/S Blokken 42 • DK-3460 Birkerød Tel: +45 4582 4440 Fax: +45 4582 5550</p>	<p>WI1028_M8M3ST005 Safety stop cabel external</p>	Version - 1.2	Date: 15-10-13	
		Approved by:	Drawn by: PCR	

# 5.15

# Cable drawings

## 5.15.3 WI1005-M12F5TF5T03P - Master/slave cable for MAC00-P4/5

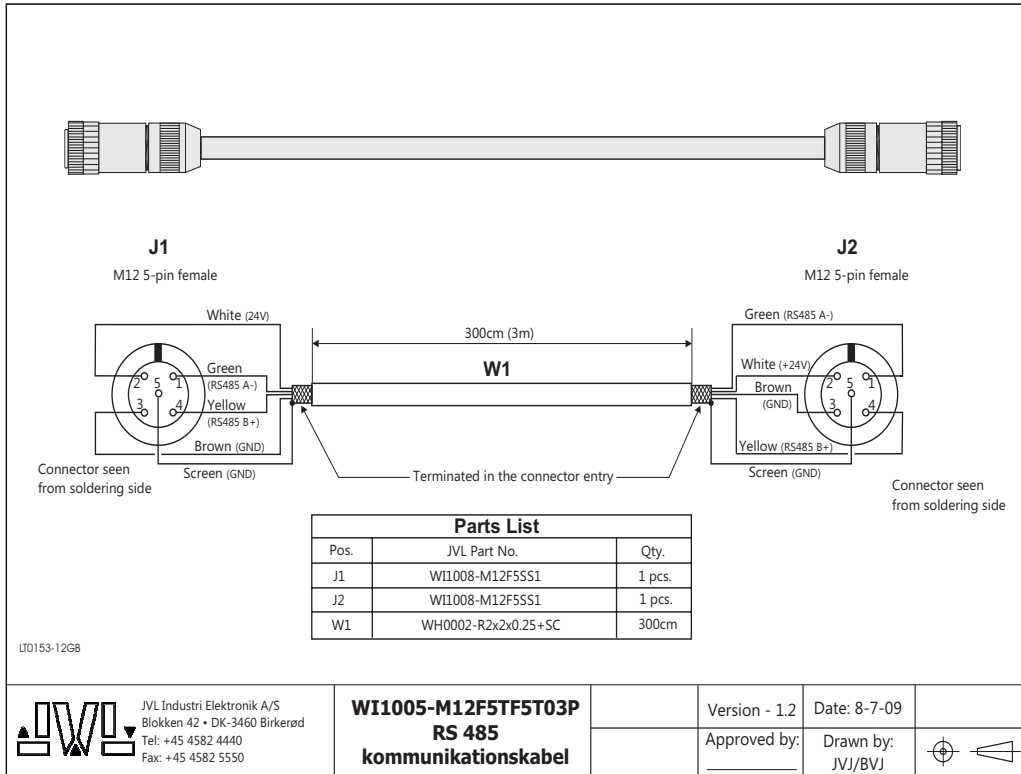

## 5.15.4 RS232-M12-1-5-5 - communication cable for MAC00-B4, R4, etc.

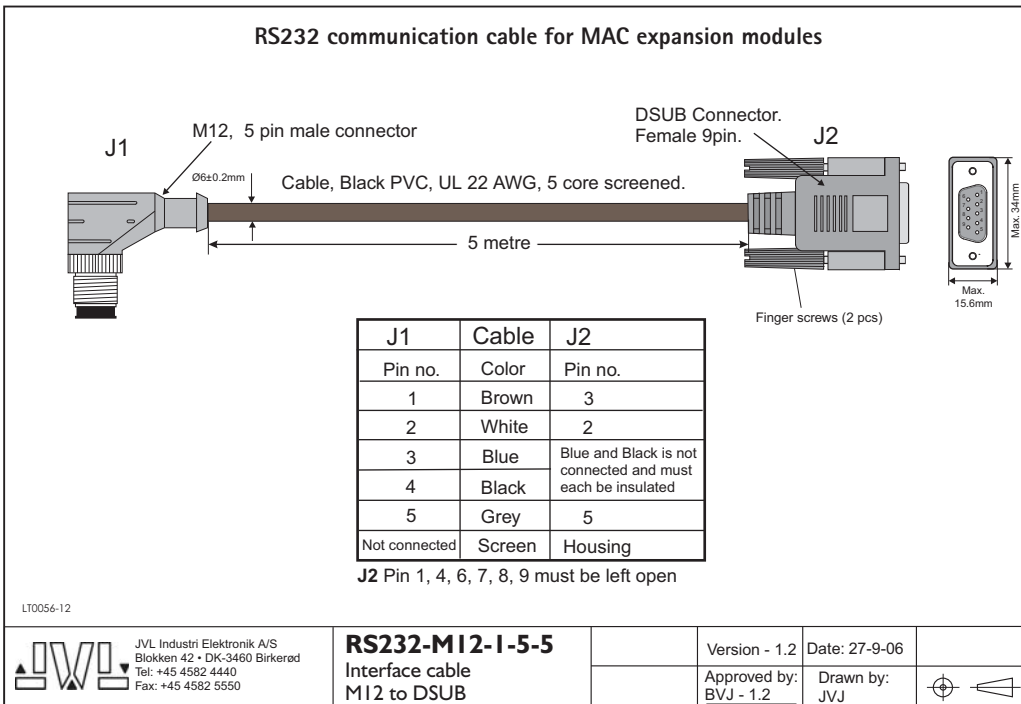



## Mechanical assessment sheet no. 1337

<b>DELTA client</b> JVL Industri Elektronik A/S Blokken 42 3460 Birkerød Denmark	<b>DELTA project no.</b> T207608
<b>Product identification</b> Series MAC400-Dx: MAC400-D2 MAC400-D3	
<b>DELTA report(s)</b> DELTA project no. T207608, DANAK-19/13991 Revision 1	
<b>Other document(s)</b> "The MAC400 integrated servo motor family", 20140214, JVL Industri Elektronik A/S – BVJ 5.4.2 Physical dimensions MAC400, JVL Industri Elektronik A/S – User Manual – Integrated Servo Motors MAC050 - 3000 5.1 Technical Data – Only MAC400, JVL Industri Elektronik A/S – User Manual – Integrated Servo Motors MAC050 - 3000	
<b>Conclusion</b> The MAC400-D2-CAGM has been tested according to the below listed standards. The test results are given in the DELTA report listed above. The tests were carried out as specified and neither malfunctions nor mechanical damages were detected.  IEC 60068-2-6: 2007, Test Fc; 5 – 25 Hz: $\pm 1.6$ mm, 25 - 500 Hz: 4 g, 1.0 oct./min., 3 x 10 sweep cycles IEC 60068-2-27, Test Ea, Shock; 15 g, 30 ms, 6 x 1000 shocks  The MAC400 integrated servo motor family covers a number of family members ie. MAC400-D2, and MAC400-D3. The tested MAC400-D2 is considered representative with respect to the test performed since the mechanical dimensions are identical. The MAC400-D3 is also equipped with shaft seal and extra coating/paint which has no influence on the ability to withstand the vibration and shock tests.  Based on the documentation mentioned above, the test results are considered to be representative for family members, MAC400-D2, and MAC400-D3.	
<b>Date</b>  Hørsholm, 7 October 2014	<b>Assessor</b>   Susanne Otto B.Sc.E.E., B.Com (Org)

# 5.16

# Vibration test certificates



## Mechanical assessment sheet no. 1332

<b>DELTA client</b> JVL Industri Elektronik A/S Blokken 42 3460 Birkerød Denmark	<b>DELTA project no.</b> T208001
<b>Product identification</b> Series MAC800-Dx: MAC800-D2 MAC800-D3 MAC800-D5 MAC800-D6	
<b>DELTA report(s)</b> DELTA project no. T208001, DANAK-19/14544	
<b>Other document(s)</b> “The MAC800 integrated servo motor family”, 20140807, JVL Industri Elektronik A/S – BVJ 5.4.3 Physical dimensions MAC800, JVL Industri Elektronik A/S – User Manual – Integrated Servo Motors MAC050 - 3000 5.1 Technical Data – Only MAC1500, JVL Industri Elektronik A/S – User Manual – Integrated Servo Motors MAC050 - 3000	
<b>Conclusion</b> The MAC800-D5 has been tested according to the below listed standards. The test results are given in the DELTA report listed above. The tests were carried out as specified and neither malfunctions nor mechanical damages were detected.  IEC 60068-2-6: 2007, Test Fc; 5 – 25 Hz: ±1.6 mm, 25 - 500 Hz: 4 g, 1.0 oct./min., 3 x 10 sweep cycles IEC 60068-2-27, Test Ea, Shock; 15 g, 30 ms, 6 x 1000 shocks  The MAC800 integrated servo motor family covers a number of family members ie. MAC800-D2, MAC800-D3, MAC800-D5, and MAC800-D6. The tested MAC800-D5 is considered representative worst case with respect to the test performed since it is equipped with the electromechanical brake option which makes it longer than the MAC800-D2 and MAC800-D3. The MAC800-D6 is also equipped with the electromechanical brake option but equipped with a teflon shaft seal which has no influence on the ability to withstand the vibration and shock tests.  Based on the documentation mentioned above, the test results are considered to be representative for family members, MAC800-D2, MAC800-D3, MAC800-D5, and MAC800-D6.	
<b>Date</b>  Hørsholm, 6 October 2014	<b>Assessor</b>   Susanne Otto B.Sc.E.E., B.Com (Org)

## 5.16

## Vibration test certificates



### Mechanical assessment sheet no. 1333

<b>DELTA client</b> JVL Industri Elektronik A/S Blokken 42 3460 Birkerød Denmark	<b>DELTA project no.</b> T208001
<b>Product identification</b> Series MAC1500-Dx: MAC1500-D2 MAC1500-D3 MAC1500-D5 MAC1500-D6	
<b>DELTA report(s)</b> DELTA project no. T208001, DANAK-19/14544	
<b>Other document(s)</b> "The MAC1500 integrated servo motor family", 20140807, JVL Industri Elektronik A/S – BVJ 5.4.5 Physical dimensions MAC1500-D2 & -D3, JVL Industri Elektronik A/S – User Manual – Integrated Servo Motors MAC050 – 3000 5.4.6 Physical dimensions MAC1500-D5 & -D6, JVL Industri Elektronik A/S – User Manual – Integrated Servo Motors MAC050 – 3000 5.1 Technical Data – Only MAC1500, JVL Industri Elektronik A/S – User Manual – Integrated Servo Motors	
<b>Conclusion</b> The MAC1500-D5-CAAL has been tested according to the below listed standards. The test results are given in the DELTA report listed above. The tests were carried out as specified and neither malfunctions nor mechanical damages were detected.  IEC 60068-2-6: 2007, Test Fc; 5 – 25 Hz: ±1.6 mm, 25 - 500 Hz: 4 g, 1.0 oct./min., 3 x 10 sweep cycles IEC 60068-2-27, Test Ea, Shock; 15 g, 30 ms, 6 x 1000 shocks  The MAC1500 integrated servo motor family covers a number of family members ie. MAC1500-D2, MAC1500-D3, MAC1500-D5, and MAC1500-D6. The tested MAC1500-D5 is considered representative worst case with respect to the test performed since it is equipped with the electromechanical brake option which makes it longer than the MAC800-D2 and MAC800-D3. The MAC800-D6 is also equipped with the electromechanical brake option but equipped with a teflon shaft seal which has no influence on the ability to withstand the vibration and shock tests.  Based on the documentation mentioned above, the test results are considered to be representative for family members, MAC1500-D2, MAC1500-D3, MAC1500-D5, and MAC1500-D6.	
<b>Date</b>  Hørsholm, 6 October 2014	<b>Assessor</b>   Susanne Otto B.Sc.E.E., B.Com (Org)

**EU - Declaration of Conformity****Manufacturer**

Company Name: JVL Industri Elektronik A/S  
 Address: Bregnerødvej 127, DK-3460 Birkerød  
 Denmark  
 Telephone: +45 45 82 44 40  
 E-mail: jvl@jvl.dk  
 Web: www.jvl.dk

**Hereby declares that:****Product**

No.: MAC50, MAC95, MAC140, and MAC141  
 Name: Integrated AC Servo Motor  
 Type: Series -A1, -A2 and -A3  
 alone or combined with one of the  
 following expansion modules:  
 MAC00-B1 / MAC00-B2 / MAC00-B4 /  
 MAC00-B41 / MAC00-B42 / MAC00-CS /  
 MAC00-P5 / MAC00-EC4/41 / MAC00-EI4/41 /  
 MAC00-EL4/41 / MAC00-EM4/41 /  
 MAC00-EP4/41 / MAC00-FS1 / MAC00-FS4 /  
 MAC00-R1 / MAC00-R3 / MAC00-R4 /  
 MAC00-FP2 / MAC00-FP4 / MAC00-FC2 /  
 MAC00-FC4 / MAC00-FC41 / MAC00-FD4

- is in conformity with:

DIRECTIVE 2014/30/EU OF THE EUROPEAN PARLIAMENT AND OF THE COUNCIL of  
 26 February 2014 on the harmonisation of the laws of the Member States relating to electromagnetic  
 compatibility

and

DIRECTIVE 2014/35/EU OF THE EUROPEAN PARLIAMENT AND OF THE COUNCIL  
 of 26 February 2014 on the harmonisation of the laws of the Member States relating to the making  
 available on the market of electrical equipment designed for use within certain voltage limits

- is manufactured in accordance with the following standards:

*EN 61800-3 Adjustable speed electrical power drives systems - part 3:*

*EMC product standard including specific test methods..*

Maj 2016



Bo V. Jessen  
 Technical Director  
 JVL Industri Elektronik A/S

LX0015-05GB

## ***EU - Declaration of Conformity***

### **Manufacturer**

Company Name:	JVL Industri Elektronik A/S
Address:	Bregnerødvej 127, DK-3460 Birkerød Denmark
Telephone:	+45 45 82 44 40
E-mail:	jvl@jvl.dk
Web:	www.jvl.dk

### **Hereby declares that:**

#### **Product**

No.:	MAC400, MAC800, MAC1500 and MAC3000
Name:	Integrated AC Servo MotorSeries
Type:	-D2, -D3, D5 and -D6
alone or combined with one of the following expansion modules:	MAC00-B1 / MAC00-B2 / MAC00-B4 / MAC00-B41 / MAC00-B42 / MAC00-CS / MAC00-P5 / MAC00-EC4/41 / MAC00-EI4/41 / MAC00-EL4/41 / MAC00-EM4/41 / MAC00-EP4/41 / MAC00-FS1 / MAC00-FS4 / MAC00-R1 / MAC00-R3 / MAC00-R4 / MAC00-FP2 / MAC00-FP4 / MAC00-FC2 / MAC00-FC4 / MAC00-FC41 / MAC00-FD4

- is in conformity with:

DIRECTIVE 2014/30/EU OF THE EUROPEAN PARLIAMENT AND OF THE COUNCIL of 26 February 2014 on the harmonisation of the laws of the Member States relating to electromagnetic compatibility

and

DIRECTIVE 2014/35/EU OF THE EUROPEAN PARLIAMENT AND OF THE COUNCIL of 26 February 2014 on the harmonisation of the laws of the Member States relating to the making available on the market of electrical equipment designed for use within certain voltage limits

- is manufactured in accordance with the following standards:

*EN 61800-3 Adjustable speed electrical power drives systems - part 3:  
EMC product standard including specific test methods..*

Maj 2016



\_\_\_\_\_  
Bo V. Jessen  
Technical Director  
JVL Industri Elektronik A/S

LX0021-03GB



## CERTIFICATE OF COMPLIANCE

**Certificate Number** 20120131-E254947  
**Report Reference** E254947-20070109  
**Issue Date** 2012-JANUARY-31  
**Issued to:** JVL INDUSTRI ELEKTRONIK A/S  
 BLOKKEN 42 3460 BIRKERØED DENMARK

**This is to certify that representative samples of**

**POWER CONVERSION EQUIPMENT**  
 Power Conversion Equipment, Cat. Nos. MAC400, MAC800, followed by D, followed by 2, 3, 5 or 6  
 Power Conversion Equipment Accessory, Low Voltage Expansion Modules, Cat. Nos. MAC00-B1, MAC00-B2, MAC00-B4, MAC00-B41, MAC00-CS, MAC00-FB4, MAC00-FC4, MAC00-FD4, MAC00-FP2, MAC00-FP4, MAC00-FR4, MAC00-FS1, MAC00-FS4, MAC00-R1, MAC00-R3, MAC00-R4, , MAC00-P4, MAC00-P5, MAC00-EC4, MAC00-EI4, MAC00-EL4, MAC00-EP4, MAC00-ES4, MAC00-EM4, MAC00-Ex4 and MAC00-EW4

Have been investigated by UL in accordance with the Standard(s) indicated on this Certificate.

**Standard(s) for Safety:** POWER CONVERSION EQUIPMENT, UL 508C

**Additional Information:** See the UL Online Certifications Directory at [www.ul.com/database](http://www.ul.com/database) for additional information

Only those products bearing the UL Recognized Component Mark should be considered as being covered by UL's Recognition and Follow-Up Service.

The UL Recognized Component Mark generally consists of the manufacturer's identification and catalog number, model number or other product designation as specified under "Marking" for the particular Recognition as published in the appropriate UL Directory. As a supplementary means of identifying products that have been produced under UL's Component Recognition Program, UL's Recognized Component Mark:  may be used in conjunction with the required Recognized Marks. The Recognized Component Mark is required when specified in the UL Directory preceding the recognitions or under "Markings" for the individual recognitions.

The final acceptance of the component is dependent upon its installation and use in complete equipment submitted to UL LLC.

Look for the UL Recognized Component Mark on the product.

William R. Carney, Director, North American Certification Programs  
 UL LLC

Any information and documentation involving UL Mark services are provided on behalf of UL LLC (UL) or any authorized licensee of UL. For questions, please contact a local UL Customer Service Representative at [www.ul.com/contactus](http://www.ul.com/contactus)



Note : MAC1500 and MAC3000 are UL Pending.

**A**

- Absolute multiturn encoder 65
- Accessories 415–416
- AIN 24, 35, 118, 120, 123, 130, 132, 136, 139, 150, 153, 156, 200, 215, 218, 222, 244, 260, 264, 276–277, 326, 329
- Air Cylinder mode 8, 119–120, 123, 135–136, 139, 152–153
  - Overall description 27
- Analogue Gear Mode 7
- Analogue Input 110–111
  - AIN 24, 35, 118, 120, 123, 130, 132, 136, 139, 150, 153, 156, 200, 215, 218, 222, 244, 260, 264, 276–277, 326, 329
- Analogue Torque mode 7–8, 27, 110, 115
- Analogue Velocity mode 7, 115
- Analogue Velocity/Gear mode 7, 114

**B**

- Balanced/push-pull signal 127, 144, 281–282
- Baud
  - Rate 165, 225, 227, 229, 249, 332, 378
- Brakes 332, 416

**C**

- Cable Connection 118
- Cable connection tables 416
- Cables 118, 130, 134, 151, 157, 160, 216, 220, 224–225, 248–249, 260–262, 265, 287, 290–291, 326–327, 330, 412, 415
- CAN-Open 4, 188–189, 217–218, 221–222
  - Introduction 160
- CE approval 4, 332, 422
- CE requirements 422
- Coil mode 7
  - Filter setup 25
  - Gear ratio 25
  - Overall description 24–26
  - Register overview 25–26
  - Zero search 25
- Connecting to other equipment 412–414
- Connector overview 86
- Connectors 86, 118–119, 124–125, 128, 130–132, 134–135, 140–141, 149–152, 155–157, 160, 215–218, 220–222, 224–225, 242–244, 248–249, 259–260, 262–

- 265, 270, 275, 279, 285–291, 323, 325–330, 366, 378, 412, 414–416
- Connector Kit MAC00-CONKIT1 86, 416
- DSUB 119, 128, 216, 262, 270, 291, 327, 415
- Interface connection 109
- M12 119, 131–132, 134, 149–151, 155–157, 160, 217–218, 220–222, 224–225, 243–244, 248–249, 263–265, 285–291, 328–330, 412
- Power Supply 86–87, 91, 96, 100, 105, 416
- User I/O 86

**D**

- Damping 56
- Declaration of Conformity 422
- DeviceNet 4, 236, 243–244, 248
  - Introduction 225
- Dimensions 342
  - MAC050-141 342
  - MAC400 and 800 343
- Dip-switch
  - settings 126, 133, 142, 155, 165–167, 217–218, 221–222, 225, 227–229, 243–244, 250, 263–264, 328
- DSP-402 Support 160, 180, 183, 188–189, 193
- DSUB 119, 128, 216, 262, 270, 291, 327, 415
- Dual Supply 119, 135, 262, 275

**E**

- Efficiency curves
  - MAC050-141 341
- Emergency Object 177
- Error acceleration 40
- Error handling 40
  - Error acceleration 40
  - Follow error 40
  - Function error 40
  - Position limit min. and max. 40
- Error output 4
- Ethernet 4
- Expansion modules 117
  - MAC00-B1/B2/B4 119, 122–127, 129, 131–134, 136–142, 144–151, 154, 276–279, 281, 285–286, 289–290
  - MAC00-CS 118

- MAC00-FC2/
  - FC4 159, 161, 183, 186, 193, 200, 220, 224
- MAC00-FD4 225, 228–230, 242–244
- MAC00-FP2/FP4 249, 251–252, 255–261, 263, 265–266, 268
- MAC00-R1/R3/R4 291–293, 295–298, 300, 324, 327–328
- F**
- Features 4
  - Basic operating modes 6
  - Overall description 5–6
- Filter selector basics 54
- Filter set-up
  - Coil mode 25
- FlexMac commands 249, 251, 254, 256–257
- Follow error 40, 54, 332
  - compensation 57
- Function description 19–27, 30–32, 34–35, 38–40, 53–58
- Function error 40
- Fuse 88
  - Prefuse, MAC800 only 101
- G**
- Gear mode 6, 21–26, 30–31, 86, 110, 113–114, 332
- Gear ratio 7, 23, 26, 196, 300
  - Coil Mode 25
- GND 87, 118, 121, 124–125, 130, 132, 137, 140–141, 150, 154–156, 215, 217–218, 221–222, 244, 260, 263–264, 277, 279, 286, 289, 323, 326, 328–329, 414
- Grounding 87, 91, 100, 105, 109, 118, 124–125, 130–132, 140–141, 149–150, 155–156, 215, 217–218, 221–222, 243–244, 260, 263–264, 279, 285–286, 288, 323–324, 326, 328–329
  - MAC800, power supply 100
  - Power supply grounding MAC050-141 87
- GSD file 266
- H**
- Hardware
  - Connector overview 86
  - Power supply 87–88, 90–92, 95–97, 99–103, 105–106
  - Serial interface 109
  - User I/O 110, 113, 115–116
- High frequency damping 56
- Home sensor 35
- Homing mode 200
- I**
- In position output 4
- Inputs
  - See also AIN
  - Analogue input 110–111
  - Multifunction I/O 5–7, 20–21, 23, 28, 31, 113–116, 118, 121, 126–127, 130, 132, 137, 142–144, 150, 154, 281–282
  - Pulse inputs 21, 23, 31, 86, 113–114, 121, 130, 137, 332, 366
  - Quadrature input 6–7, 21, 23, 31, 113–114
- Introduction
  - Features 4, 12
  - Overall description 5–6
- IP42 119, 291, 332
- IP67 118–119, 129, 131, 134, 151, 155, 157, 160, 217, 220–221, 224–225, 243, 248–249, 263, 265, 287, 290–291, 325, 328, 330, 332
- J**
- Jetter JX2-SM2 414
- Jetter JX2-SVI 412–414
- Jetter PLC 412, 414
- JX2-SM2 414
- JX2-SVI 413
- L**
- LOAD parameter 25, 53–54, 58, 367
- Low frequency damping 56
- M**
- M12 119, 131–132, 134, 149–151, 155–157, 160, 217–218, 220–222, 224–225, 243–244, 248–249, 263–265, 285–291, 328–330, 412
- MAC00-B1/B2/B4 Expansion
  - Modules 119, 122–127, 129, 131–134, 136–142, 144–151, 154, 276–279, 281, 285–286, 289–290
  - Overall description 119, 135, 152, 275
  - General analogue input (AIN) 123, 139
  - General hardware
    - aspects 120, 136, 153, 276
  - MAC00-B2 with cables 130
  - MAC00-B4 cables 134, 151, 287, 290
  - Multifunction I/O 126, 142

- Power supply 122, 138, 278
- RS232 124, 140, 279–280
- RS485 125, 141, 323
- MAC00-CONKIT1 416
- MAC00-CS Expansion module 118
- MAC00-FC2/FC4 Expansion
  - Modules 159, 161, 183, 186, 193, 200, 220, 224
  - CAN-Open 160
  - MAC00-FC2 cables 160
  - MAC00-FC2 RS232 interface cables 216
  - MAC00-FC4 cables 220, 224
  - Transmit PDOs 189
- MAC00-FD4 Expansion Module 225, 228–230, 242–244
  - Cables 225, 248
  - DeviceNet 225
  - Hardware, general 242
  - Node-id, Baud Rate, Termination 227
  - Position controller 230
- MAC00-FP2/FP4 Expansion
  - Modules 249, 251–252, 255–261, 263, 265–266, 268
  - Address, Termination 250
  - Assembly instruction for profi cables 261
  - Cables 249
  - Connectors 259
  - Dual-supply operation 262
  - FlexMac commands 257
  - GSD file 266
  - Input data (Slave-Master) 254
  - Input modes 255
  - MAC00-FP2 RS232 cable 262
  - MAC00-FP2 with cables 260
  - MAC00-FP4 cables 265
  - Profibus 249
  - RS232 262
  - Slave parameters 256
- MAC00-R1/R3/R4 Expansion Modules 291–293, 295–298, 300, 324, 327–328
  - General description 291
  - Command toolbox description 300
  - Firmware setup 292
  - MAC00-R3 cables 291
  - MAC00-R3 RS232 cable 327
  - MAC00-R3 with cables 326
  - MAC00-R4 cables 157, 330
  - Programming hints 299
  - Rx (fixed format) 292
  - RxP (Graphic programming) 292–293, 295–298, 300
- MAC050-141
  - Adjusting the current filter 55
  - Efficiency curves 341
  - Physical dimensions 342
  - Power supply 87–88
  - Power supply dimensioning 88
  - Power supply grounding 87
  - Serial communication 378–381
  - Technical data 332
  - Torque curves 338
- MAC800
  - Physical dimensions 343
  - Power dump resistor 102
  - Power supply circuitry 99
  - Power supply connection 100
  - Power supply grounding 100
  - Prefuse 101
  - Technical data 335–337
  - Torque curves 339
  - Using 115V supply 101
- MacTalk 4, 6, 15–16, 20, 25, 32, 39, 53–54, 86, 110, 112, 116, 121, 124, 130, 137, 140, 166, 192, 279, 292, 297, 302, 366, 378
  - Coil mode register overview 25–26
  - Introduction 14
- Main Features 4
- Master-Slave Output Data
  - MAC00-FP2/FP4 Expansion Modules
    - Output data (Master-Slave) 251
- Mechanical zero
  - search 14, 22, 25, 30, 32, 34–35, 38–39, 86, 110, 119–120, 136, 153
  - See also Zero search
- Multifunction I/O 5, 21, 28, 113–116
  - See also Inputs
  - MAC00-B1/B2/B4 126, 142
- N**
- nano-PLC 4, 291
- Node-id 166–167, 227–228
- NPN 112, 119, 126, 128–129, 142–143, 270, 325, 332
- O**
- O1 Output 112
  - See also Outputs
- O2 Output 112
  - See also Outputs
- Operating modes
  - Analogue Gear mode 7

- Analogue Torque mode 7
- Analogue Velocity mode 7
- Analogue Velocity/Gear mode 7
- Changing operation modes 199
- Coil mode 24–26
- Gear mode 6, 21–23, 30–31
- Introduction 6
- Passive mode 6
- Position mode 6, 20
- Velocity mode 6
- Oscillation 56, 367
- Outputs
  - Multifunction I/O 113–116
    - See also Inputs
  - Pulse outputs 115
  - Quadrature output 20–
    - 21, 86, 113, 115
  - Status outputs O1, O2 112, 118–
    - 119, 121, 128–
    - 130, 132, 137, 150, 154, 156, 181–
    - 182, 215, 218, 222, 234, 244, 260,
    - 264, 270, 325–326, 329
- Overall description of the MAC motors 5–6
- P**
- Passive mode 6
- PDOs 160, 183, 188–190, 201
- PLC 86, 109, 116, 266, 332, 412, 414
  - nano-PLC 4
- PNP 112, 119, 121, 126–
  - 130, 132, 137, 142–
  - 143, 154, 156, 215, 260, 264, 270, 32
  - 5–326, 329
- Position controller 7, 225, 230, 236
- Position limit min. and max. 40
- Position mode 6, 20
  - Using Position mode 20
- Position/Velocity filter 55
- Power dump 90–91, 95, 99–
  - 100, 103, 332, 416
  - MAC800 102
- Power Supplies 88, 416
- Power Supply 86–88, 90–92, 95–97, 99–
  - 103, 105–106, 118
  - Circuitry, MAC800 99
  - Dimensioning, MAC050-141 88
  - Grounding MAC050-141 87
  - MAC00-B1/B2/B4 120, 136, 153, 276
  - MAC800 connection 100
  - MAC800 grounding 100
  - Power dump resistor, MAC800 102
  - Using 115V, MAC800 only 101
- Prefuse 101
- Profibus 4, 214, 250, 256, 259, 263–
  - 266, 415
  - Introduction 249
- Profile position mode 199
- Pulse inputs 114
  - See Inputs
- Pulse outputs 115
  - See also Outputs
- Push-pull signal 127, 144, 281–282
- Q**
- Quadrature input
  - See Inputs
- Quadrature Output
  - See Outputs
- R**
- Register overview
  - Coil mode 25–26
- RS232 4, 86, 109, 119, 130–
  - 131, 135, 152, 215, 275, 325–
  - 327, 332, 366, 378, 415–416
  - Interface signal levels 109
  - MAC00-B1/B2/B4 124, 140, 279–280
  - MAC00-FP2/FP4 Expansion Modules 262
- RS485 109, 119, 135, 152, 155, 275, 32
  - 5–326, 328, 332, 415
  - MAC00-B1/B2/B4 125, 141, 323
- Rx (fixed formats) 292
- RxP (Graphic programming) 292, 294
- S**
- Saving, retrieving disk files 16
- Serial communication 116, 118, 332
  - MAC050-141 378–381
- Serial Interface 109, 129, 325, 378
  - Multifunction I/O 116
  - Signal levels 109
- Servo filter adjustment 53–58
  - Additional adjustment 58
  - Adjusting the LOAD parameter 53
  - Current filter adjustment (MAC050-141
    - only) 55
  - Damping 56
  - Filter selector basics 54
  - Follow error compensation 57
  - Position/Velocity filter 55
  - Transferring, saving filter 58
- Setting up the MAC Motor 14–15
  - Disk files 16
  - MacTalk 14
  - Toolbar description 15
- Shaft reinforcements 416

- Signal levels, serial interface 109
- Slave-Master 254
- SSI interface 59
- Status outputs
  - See Outputs
- T**
- Technical data
  - MAC050-141 332
  - MAC800 335–337
- Termination 220, 224, 227, 248, 250, 264–265
- Torque curves
  - MAC050-141 338
  - MAC400, MAC800 339
- Torque zero search 32, 34
- Trouble-shooting 366–367
- U**
- UL approval 4
- USB 132, 150, 366
- User I/O 86, 110, 113, 115–116
  - Analogue input 110–111
  - Multifunction I/O 113–116
  - Status outputs 112
- V**
- Velocity mode 6, 200
- Z**
- Zero search 14, 22, 25, 30, 32, 34–35, 38–39, 86, 110, 119–120, 123, 128–129, 132, 136, 139, 150, 153, 156, 192, 215, 236, 257, 260, 270, 286, 289, 325–326, 329, 332
  - Coil mode 25
  - Index position after zero search 39
  - Modes 32
  - Sensor type 33
  - Sensor type 1 35–37
  - Sensor type 2 35
  - Starting a zero search 33
  - Torque 32, 34
  - Zero point offset 38

