

GTX SERIES actuators

**CURTISS -
WRIGHT**

Installation & Service Instructions

Rev. F | PN75557 | 12/18/2019

EXLAR®

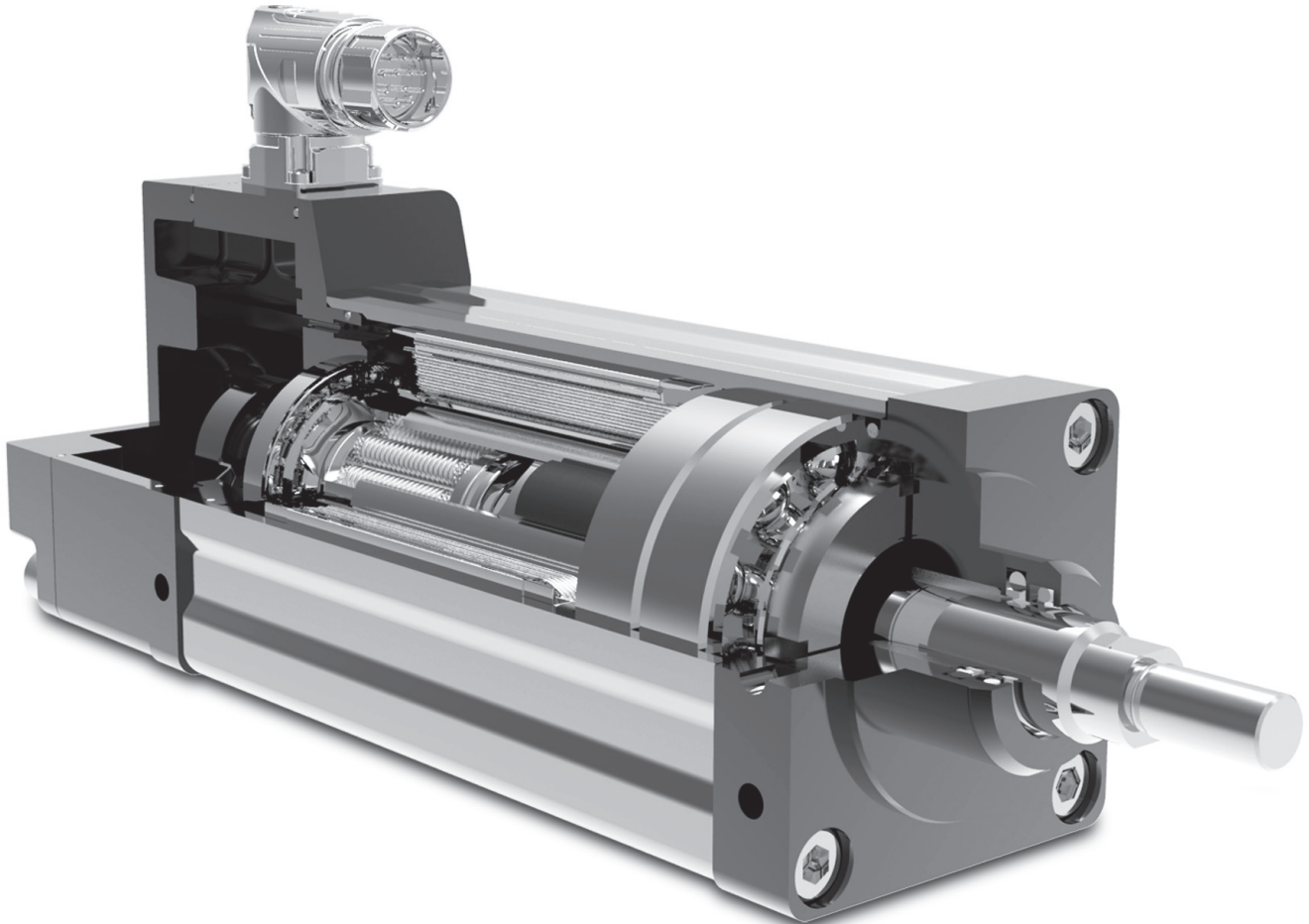

This document does not contain any export-controlled technical data.

Information furnished by Exlar Corporation is believed to be accurate and reliable. However, no responsibility is assumed by Exlar Corporation for its use. Exlar reserves the right to change the design and operation of the equipment described herein and any associated motion products that may appear in this document. Information in this document pertaining to equipment not furnished by Exlar should be confirmed by that equipment manufacturer. Exlar assumes no responsibility for changes to information by other manufacturers or errors in that information or the description of that information. Information in this document is subject to change without notice.

CONTENTS

1.0 INTRODUCTION	3	6.0 MAINTENANCE PROCEDURES	13
1.1 General Product Description	3	6.1 Lubrication.....	13
1.2 Product Features.....	3	Grease Renewal Procedure	14
1.3 Safety Considerations	4	6.2 Seal Maintenance	14
2.0 SYSTEM CONFIGURATION	5	6.3 Replacement Faceplate Assembly Kit.....	14
2.1 GTX Series Actuator	5	7.0 TROUBLESHOOTING.....	15
2.2 Options.....	5	8.0 PRODUCT RETURNS.....	16
2.2.1 Servomotor Amplifiers	5	9.0 CERTIFICATIONS	16
2.2.2 Feedback Devices.....	5	9.1 Importer Requirements	17
2.2.3 Resolvers	5	9.2 Distributor Requirements	17
2.2.4 Encoders	5	10.0 WARRANTY INFORMATION	18
2.2.5 Internal Holding Brake.....	5		
2.2.6 Anti-Rotation Assembly	5		
2.2.7 External Limit Switch.....	5		
3.0 MECHANICAL INSTALLATION	6		
3.1 Mounting Configurations	6		
3.2 Mounting Considerations	7		
3.2.1 Actuator Alignment	7		
3.2.2 Feedback Device Alignment.....	7		
3.2.3 Anti-Rotation Assembly	8		
3.3 Lubrication.....	10		
4.0 ELECTRICAL INSTALLATION.....	10		
4.1 Safety Considerations	10		
4.2 Cable Routing	10		
4.3 Amplifier Pinouts And Connections	11		
4.4 Connecting Optional Equipment	11		
4.4.1 Feedback Devices – Encoders	11		
4.4.2 Internal Holding Brake.....	11		
4.4.3 External Limit Switch	11		
5.0 STARTUP	12		
5.1 Considerations For Startup	12		
5.1.1 Safety Considerations.....	12		
5.1.2 Amplifier Software	12		
5.1.3 Rotary-To-Linear Motion Relationship.....	12		
5.1.4 Amplifier Wiring	12		
5.2 General Startup Procedure	12		

1.0 INTRODUCTION

1.1 GENERAL PRODUCT DESCRIPTION

GTX Series actuators feature a robust planetary roller screw mechanism integrated into the rotor of a brushless servomotor. This unique design combines the high speed and high load capacity of the roller screw with the high torque-to-volume ratio of the brushless servomotor.

Completing the actuator design is the choice of feedback devices. The most common types of feedback devices are resolvers, incremental encoders, and absolute encoders. Selecting the proper feedback configuration allows GTX Series actuators to be powered by brushless motor amplifiers readily available from most leading motor manufacturers.

GTX Series actuators offer a true all-electric replacement solution for cumbersome, high-maintenance hydraulic systems. Electronic servo control also provides simpler setup and more precise control than hydraulic systems. This flexibility makes GTX Series actuators an excellent motion control solution for today's highest performance single- and multi-axis applications. From food and beverage packaging to multi-axis turning centers to aircraft assembly, GTX Series actuators deliver outstanding performance and durability.

GTX Series actuators feature an Ingress Protection Rating of IP65S.

1.2 PRODUCT FEATURES

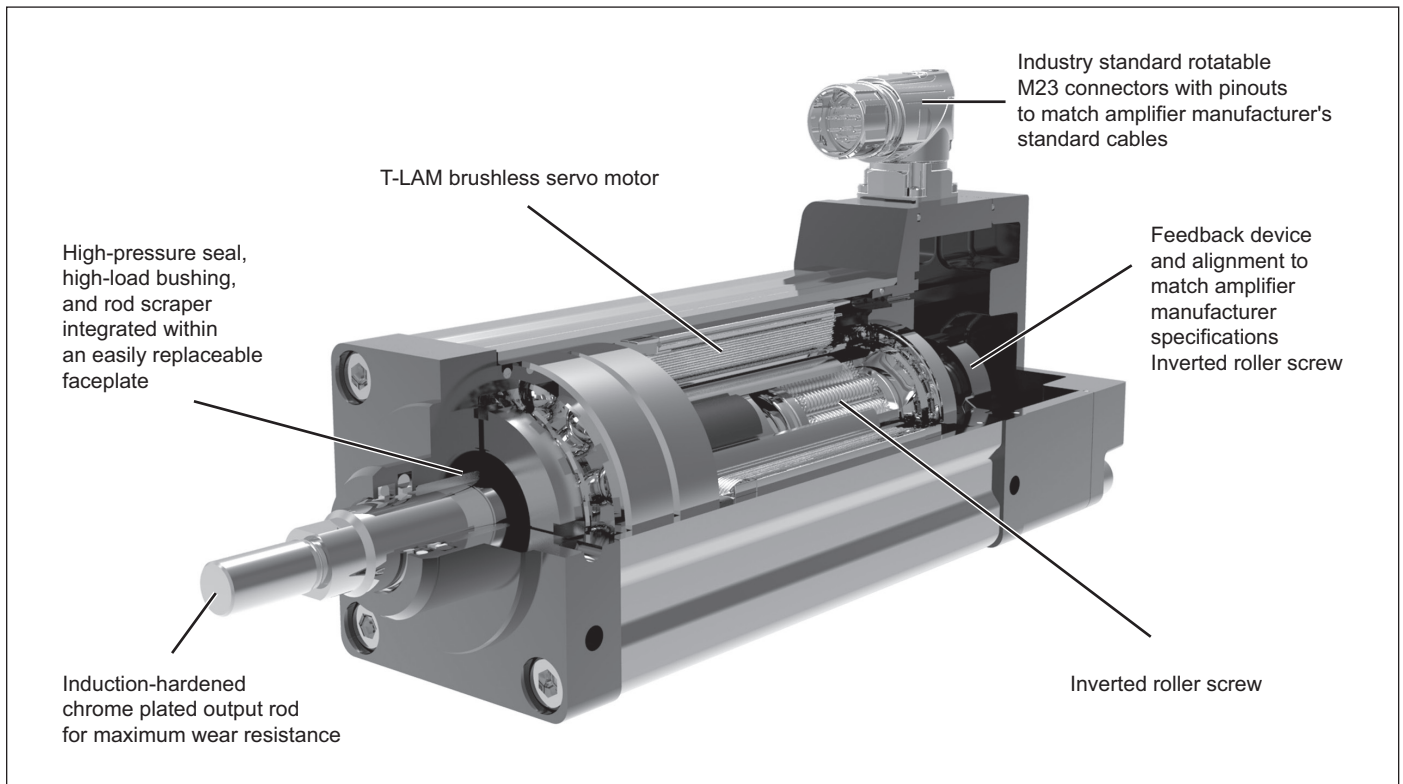

Figure 1 – GTX Series Actuator features

1.3 SAFETY CONSIDERATIONS

Safety is of paramount importance during the installation and operation of your GTX Series actuator. Throughout this manual, content flagged with the cautionary symbols shown below should be read carefully by installers and operators to help avoid property damage, personal injury or death.



DANGER! Indicates an extremely hazardous situation which will result in serious injury or death if precautions are not followed. Extreme care should be taken in these situations.



WARNING! Indicates a potentially hazardous situation which could result in serious injury or death if precautions are not followed. Extra care should be taken in these situations.



CAUTION! Indicates a potentially hazardous situation which could result in property damage or minor to moderate injury.

IMPORTANT! Identifies statements that provide important information to help ensure safe and trouble-free installation and operation.

2.0 SYSTEM CONFIGURATION

2.1 GTX SERIES ACTUATOR

GTX Series actuators provide a robust solution for long-life, continuous-duty applications even when environmental contaminants are an issue. In most rotary-to-linear devices, critical mechanisms are exposed to the environment and must be frequently inspected, cleaned and lubricated. In contrast, GTX Series actuators are designed with all converting components mounted within sealed motor housings. With a simple bushing and seal on the smooth extending rod, abrasive particles or other contaminants are prevented from reaching the actuator's critical mechanisms. As a result, actuator life can exceed that of a ball screw actuator by 15 times, even in high-speed, high-force applications.

2.2 OPTIONS

2.2.1 Servomotor Amplifiers

GTX Series actuators function in the same manner as a brushless servomotor. A brushless servo motor amplifier is used to rotate the motor for a controlled number of revolutions and move times at controlled speed and torque. This rotary motion is translated into linear motion by the GTX Series actuator's internal planetary roller screw mechanism.

2.2.2 Feedback Devices

Feedback device selection is dictated by the amplifier used to operate the actuator. Each amplifier has specific requirements for motor feedback. Standard GTX Series actuators use either a 2-pole resolver or quadrature incremental encoder as their primary feedback device.

2.2.3 Resolvers

A resolver is a non-electronic device that functions similarly to a small transformer. When rotated, the resolver generates two sine waves that are out of phase with one another. By decoding these two sine waves, the amplifier can monitor the motor direction, revolutions traveled, and speed of rotation. Each sine wave typically represents one revolution of the motor. The amplifier uses these signals to identify where the motor is within that revolution and properly time the supply of current and voltage to the motor for it to rotate. This process is known as "commutation". For the amplifier to properly commutate the motor, it must have a reference (or "zero") point from which to track the motor's rotation.

IMPORTANT! The zero point is critical and is provided to the amplifier through the proper alignment of the resolver to the phases of the motor during the actuator assembly. **NOTE:** Not all resolver-based amplifiers can use the same resolver, resolver alignment, or relative direction of resolver rotation.

2.2.4 Encoders

An incremental encoder is an electronic rotary device that transmits a string of electrical pulses when rotated to measure position. A quadrature encoder (or "incremental rotary encoder") measures the speed and direction of a rotating shaft. Most brushless motor or servo systems with incremental encoders use a quadrature encoder. **NOTE:** Not all encoder-based amplifiers can use the same encoder, encoder alignment or relative direction of encoder rotation.

2.2.5 Internal Holding Brake

Many applications require the addition of a holding brake. The Exlar internal holding brake is engaged by a permanent-magnet. The mechanical advantage of the roller screw allows the holding brake to prevent the output rod from back-driving the load. The holding capacity of the brake is sufficient to hold the rated force of the actuator.

2.2.6 Anti-Rotation Assembly

The unique design of GTX Series actuators helps simplify actuator setup by allowing the user to rotate the extending rod and thread it in and out of the actuator for mechanical attachment or system testing. In most applications, the load is coupled to linear bearings or some other support device, preventing rotation during operation. To ensure proper linear motion in applications in which the rod is free to rotate, an Anti-Rotate Assembly is required to prevent the rod from rotating.

2.2.7 External Limit Switch

A GTX Series actuator equipped with the anti-rotate and limit switch options can accommodate multiple limit switches for use as end-of-travel limit switches or home position sensors positioned outside the low-profile extruded channel housing.

3.0 MECHANICAL INSTALLATION

3.1 MOUNTING CONFIGURATIONS

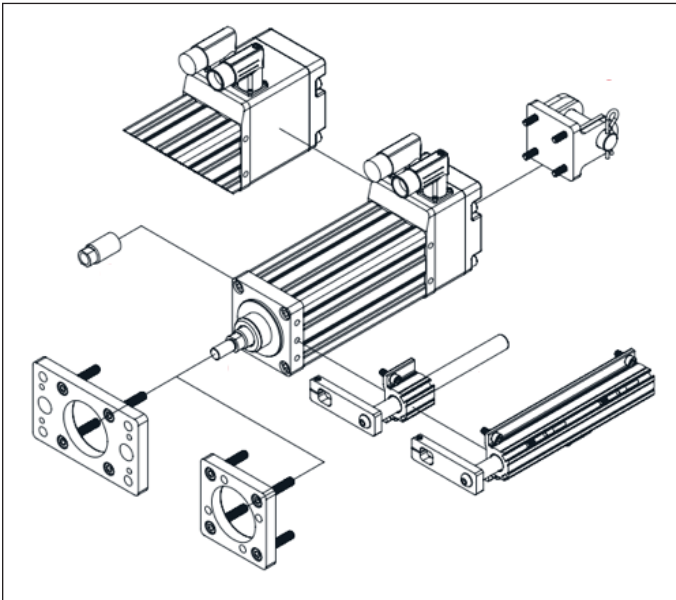

Figure 2 – Mounting configurations

GTX Series actuators mounting configurations:

- Rear clevis
- Front flange
- Tapped face
- Side mount.

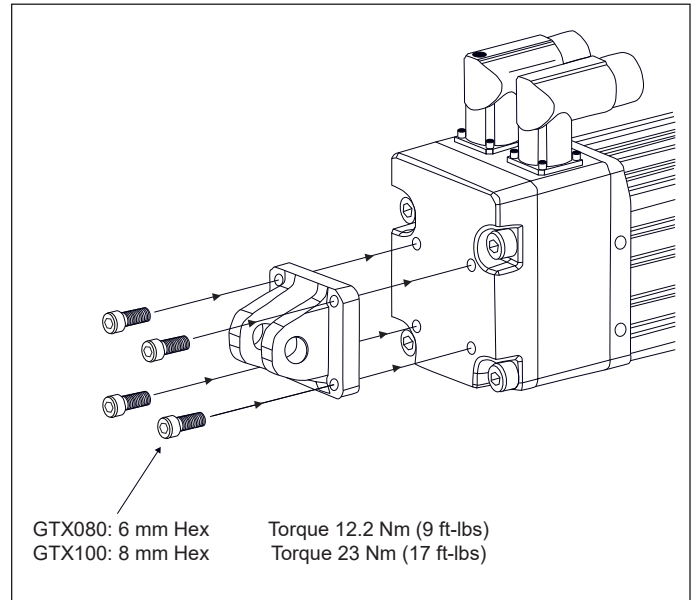

Figure 3 – Rear clevis mount (**NOTE:** Dimension drawings can be found in the GTX Series Actuator catalog or on the Exlar website.)

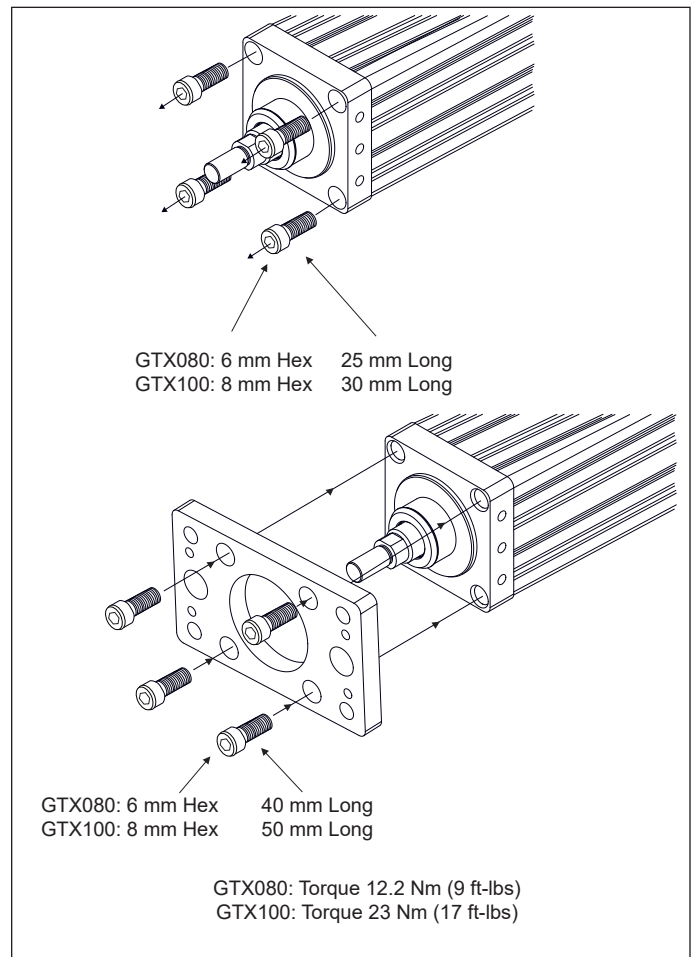

Figure 4 – Flange mount

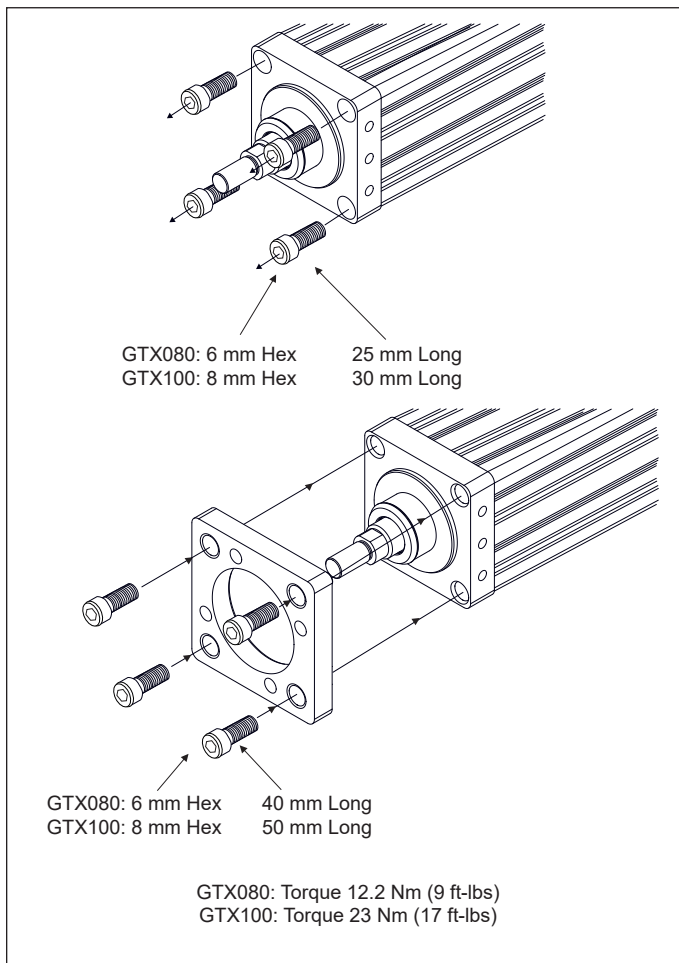

Figure 5 – Tapped face mount

3.2 MOUNTING CONSIDERATIONS

3.2.1 Actuator Alignment

IMPORTANT! Aligning the GTX Series actuator with respect to the load it is moving is critical. Any misalignment will decrease the life of the actuator's components and may adversely affect application performance.

! CAUTION! Excessive side load on the actuator output rod will dramatically reduce the life of the actuator and should be avoided. Side load can result from misalignment or loading that is not in line with the actuator output rod.

Side-mounting notes:

GTX Series actuators include threaded holes in the faceplate and endplate. Exlar recommends using hardened fasteners to mount an actuator to your machine frame with an engagement depth of two times the screw diameter for tapped holes.

IMPORTANT! Tighten four cap screws to 12.24 Nm (9.0 ft-lb) max. Failure to properly tighten the screws can affect normal operation, damage the actuator and/or cause possible premature actuator failure.

3.2.2 Feedback Device Alignment

Every GTX Series actuator is mounted, aligned and tested using the customer-specified feedback device and amplifier (or an equivalent amplifier) to ensure proper feedback alignment and operation. Should an installed feedback device become misaligned or there is a change in amplifier status, contact the Exlar factory to make arrangements to have the alignment readjusted.

3.2.3 Anti-rotation Assembly

To keep the extending rod from rotating, Exlar offers the Anti-rotation Assembly shown in Figure 6.

Figure 6 – Anti-rotation Assembly (shown in standard location)

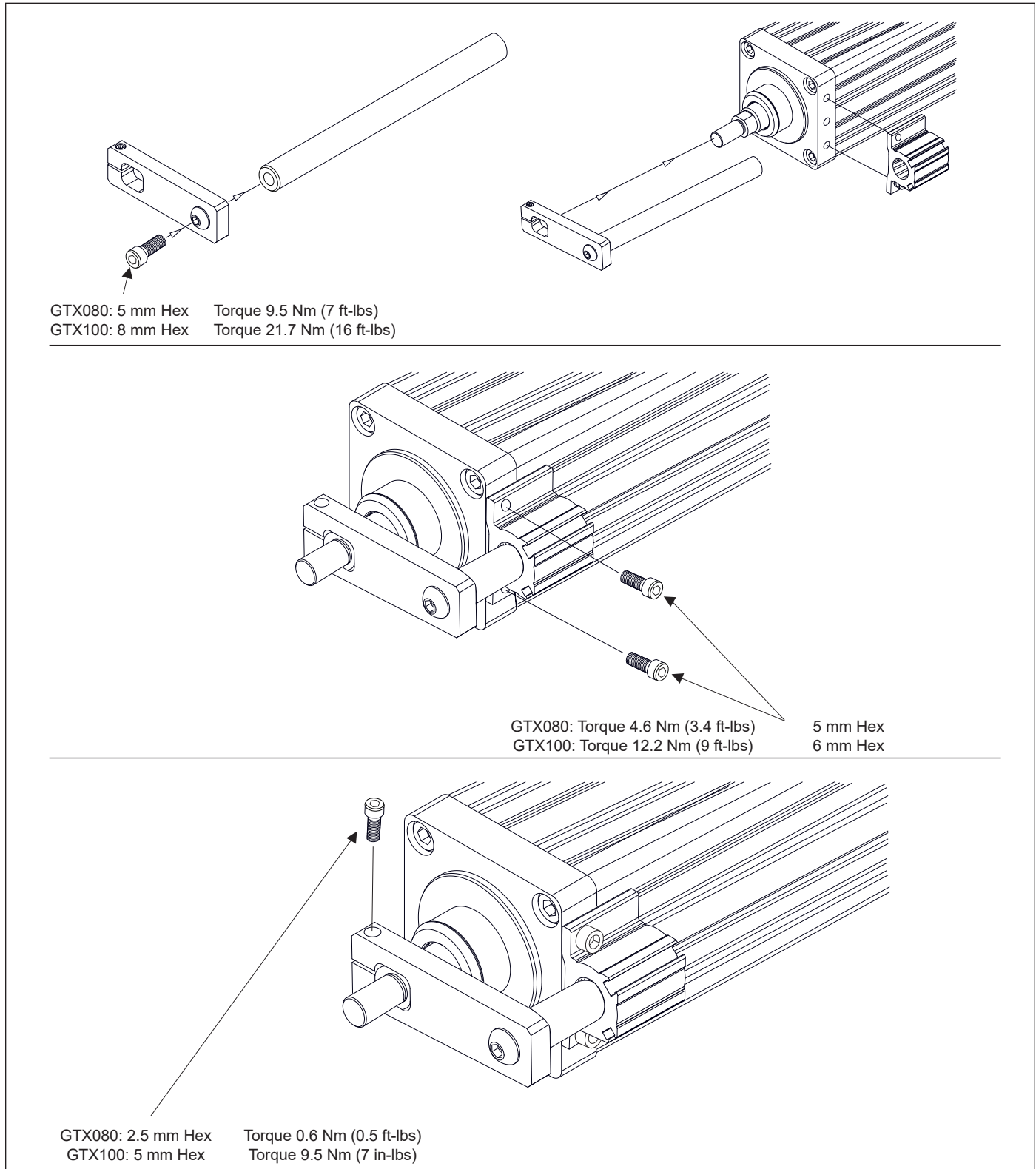

3.2.4 External Limit Switches

This option allows multiple external switches (sold separately) to be externally mounted to the actuator. These adjustable switches provide travel indication to the controller. A bracket

with inductive proximity switches mounts to the outside low-profile extrusion and senses a traveling magnet located inside the anti-rotate tube.

Figure 7 – Limit switch mounting

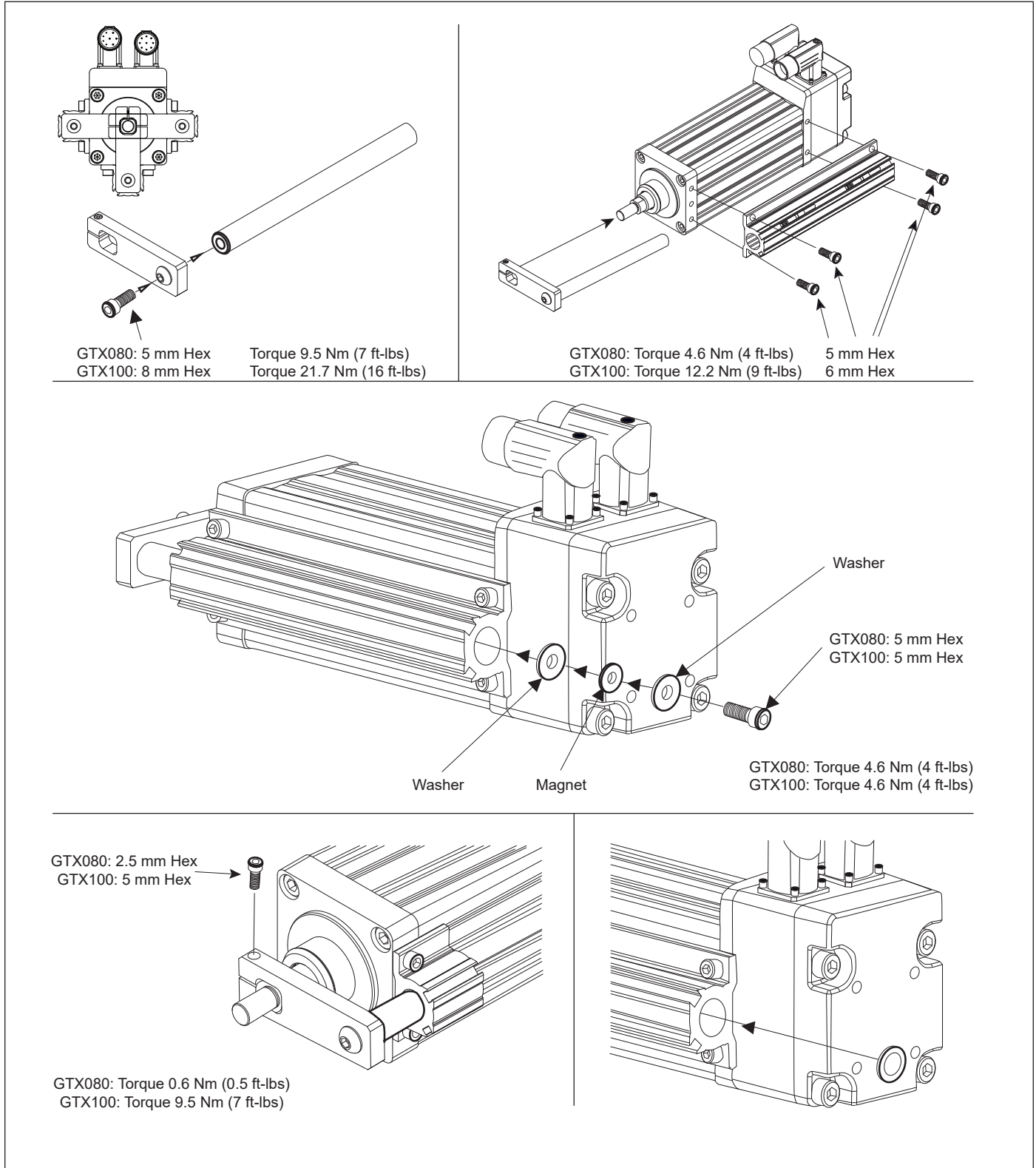

4.0 ELECTRICAL INSTALLATION

3.3 LUBRICATION

GTX Series actuators are shipped from the factory fully greased and ready for installation. Exlar uses Mobil SHC 220, a high-performance grease that performs well under extreme pressure. The unique physical properties of the synthetic-based oil provide outstanding protection against wear, rust, corrosion and high- or low-temperature degradation. Mobil SHC allows for very low starting and running torque values. The Mobil SHC220 operating range is -40° C to 177° C (-40° F to 350° F).

4.1 SAFETY CONSIDERATIONS

⚠ DANGER! ***NEVER** attempt to connect or disconnect an actuator with power applied. Dangerous voltages are present with the potential to cause equipment damage and/or personal injury or death. Many amplifiers have voltage present for a considerable time period after incoming power is removed. Use extreme caution to ensure all amplifiers have discharged all power before proceeding.*

⚠ WARNING! Do NOT attempt to connect the power cable to the motor feedback connector as this may cause damage to the connector. Verify that pin patterns match before attempting to connect cables to the actuator.

⚠ CAUTION! GTX Series actuators can be operated under a variety of conditions. General safety practices such as lock-out and tag-out procedures should be followed during the electrical installation of GTX Series actuators.

⚠ CAUTION! Motor RMS current must be maintained at a level below the continuous current rating of the GTX Series actuator or damage to the motor stator will result. The peak current setting must be maintained at a level below the peak current rating of the GTX Series actuator or damage to the stator will result.

4.2 CABLE ROUTING

To minimize the introduction of contaminants to the connector, route the cables so there is a loop in the cable just prior to its attachment to the connector (see Figure 8). Units mounted with the connectors on the bottom surface of the actuator require no looping.

IMPORTANT! Follow cable manufacturers' recommended cabling bend radius.

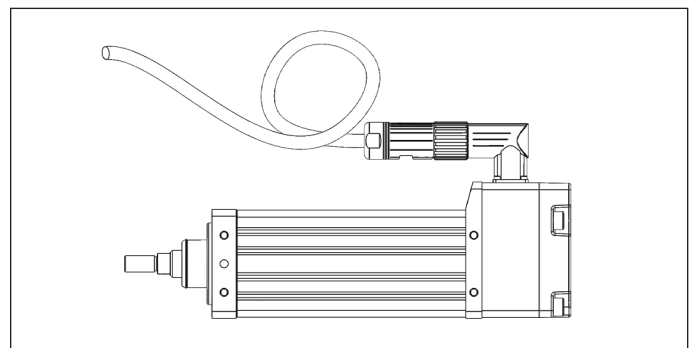

Figure 8 – Cable routing

4.3 AMPLIFIER PINOUTS AND CONNECTIONS

GTX Series actuators are designed to seamlessly integrate with leading amplifier manufacturers' products, allowing the use of amplifier manufacturers' supplied cables. Actuator connections will vary depending on the amplifier used to operate the actuator. (Consult the GTX Series Actuator catalog or the Exlar website for compatible amplifiers.)

4.4 CONNECTING OPTIONAL EQUIPMENT

4.4.1 Feedback Devices – Encoders

Proper feedback device wiring is critical to the operation of the actuator with the selected amplifier. Based on the customer's drive selection, Exlar installs, aligns, and wires feedback devices to match the drive manufacturer's specifications and cabling.

IMPORTANT! Modifying or improperly wiring the feedback device can cause unstable operation, incorrect operation or no operation at all.

Typical brushless motor encoders use two data channels labeled "A&B" to provide direction, velocity and position information. The channel labeled "I" or "Z" has one pulse per revolution and is called the "Index". The channels identified as "Hall Signals" or "Commutation Signals" are typically labeled "S1, S2 & S3", "Hall 1, 2 & 3", or "Hall A, B & C", depending on the manufacturer's conventions. These signals provide the amplifier with the commutation information it needs to properly rotate the motor.

CAUTION! In some cases, improper current limits set in the amplifier and incorrect wiring of the feedback device can lead to motor damage.

4.4.2 Internal Holding Brake

The brake is held open by the supply of 24 Vdc power to a magnetic/mechanical clutch. When there is no power to the brake, the armature is held in place preventing the inverted roller screw from turning.

4.4.3 External Limit Switch

Depending on the specified switch configuration, the switches are 10 to 30 Vdc powered, PNP or NPN output, with normally open or normally closed logic operation. Figure 9 provides additional information about available Exlar switches.

Switch Type	Exlar Part No.	Turck Part No.	3-Wire, 10-30 Vdc
Normally Closed, PNP Output	43404	BIM-UNT-RP6X	
Normally Open, PNP Output	43403	BIM-UNT-AP6X	
Normally Closed, NPN Output	67635	BIM-UNT-RN6X	
Normally Open, NPN Output	67634	BIM-UNT-AN6X	

Figure 9 – Logic switch part numbers

5.0 STARTUP

5.1 CONSIDERATIONS FOR STARTUP

5.1.1 Safety Considerations

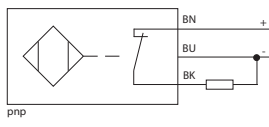
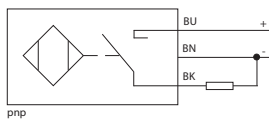
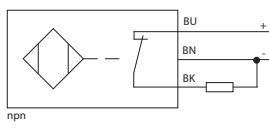
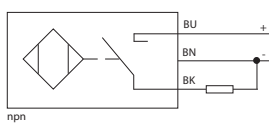
⚠ WARNING! NEVER attempt to connect or disconnect the actuator with power applied. Many amplifiers have voltage present after incoming power is removed. Ensure that the amplifier has discharged all power.

⚠ CAUTION! Do NOT exceed the maximum input voltage for GTX Series actuators (460 Vac).

5.1.2 Amplifier Software

Many amplifiers offer software that allows the user to enter the above parameters or download “motor data files” that dictate how the feedback must be set up on the motor. These parameters are available in the GTX Series Actuator catalog or on the Exlar website. **NOTE:** Entering motor parameter data to some amplifiers may require assistance from the amplifier manufacturer.

5.1.3 Rotary-to-Linear Motion Relationship

The relationship between the rotary motion of the motor and the linear motion of the actuator is based on the following parameters:

$$L_D = \text{Rev} \times R$$
$$L_S = [\text{RPM}/60] \times R$$
$$L_F = [T \times (2\pi \times E/R)]$$

where:

E = Efficiency

L_D = Linear distance traveled

L_S = Linear speed

L_F = Linear force

R = Roller screw lead

REV = Motor revolutions

RPM = Motor revolutions per minute

T = Motor torque

NOTE: Each of the above relationships requires proper anti-rotation of the actuator rod.

5.1.4 Amplifier Wiring

Each brand of brushless motor amplifiers may have unique wiring requirements, parameter settings, and operational principles that affect how the actuator operates. For more information on sizing and selecting GTX Series actuators and the brushless servo motor amplifiers used to power them, consult the sizing and selection section of the GTX Series actuator catalog.

5.2 GENERAL STARTUP PROCEDURE

IMPORTANT! Exlar recommends testing new systems prior to live operation (see example startup procedure below).

1. Connect wiring or cables from the amplifier to the actuator using cables supplied by the drive manufacturer.

⚠ CAUTION! Verify that pin patterns match before attempting to connect cables to the actuator.

2. Apply input power to the amplifier.

⚠ CAUTION! Motor RMS current must be maintained at a level below the continuous current rating of the GTX Series actuator or damage to the motor stator will result. The peak current setting must be maintained at a level below the peak current rating of the GTX Series actuator or damage to the motor stator will result.

3. Input key motor parameters into the amplifier settings.

NOTES:

- Some drives require motor files to be input. For additional guidance regarding amplifier-specific settings or operation, consult the amplifier manufacturer.
- Motor parameters and motor files can be found on the Exlar website.
- Set peak current less than two times the current rating on the actuator label.

4. Enable the amplifier.
5. Download parameters to the amplifier.
6. Run “auto-tune” or “auto-commutate” to double-check alignment.
7. If necessary, re-download parameters to the amplifier.
8. In Jog mode, index the actuator rod at 10% of the rated actuator speed.
9. Check to ensure the linear distance traveled matches the theoretical distance based upon motor revolutions and roller screw lead.
10. Review end-of-travel limits internal to the actuator and set maximum revolutions per extend/retract direction to ensure end-of-travel limits are not reached.

⚠ CAUTION! Do NOT exceed the actuator’s physical travel limits. End-of-stroke impacts can cause permanent damage to the actuator.

6.0 MAINTENANCE PROCEDURES

11. Create an index program to cycle the actuator in both the extend and retract directions at rated speed.
12. Set acceleration to 10 times the rated actuator speed.
13. If the actuator cycles without any amplifier error messages or abnormal behavior, couple the actuator to the load and begin commissioning the overall system.

NOTES:

- GTX Series actuators can be operated at current levels two times the current rating for short amounts of time.
- When operating the actuator in the peak current range, follow the duty cycle limits shown in Figure 10.

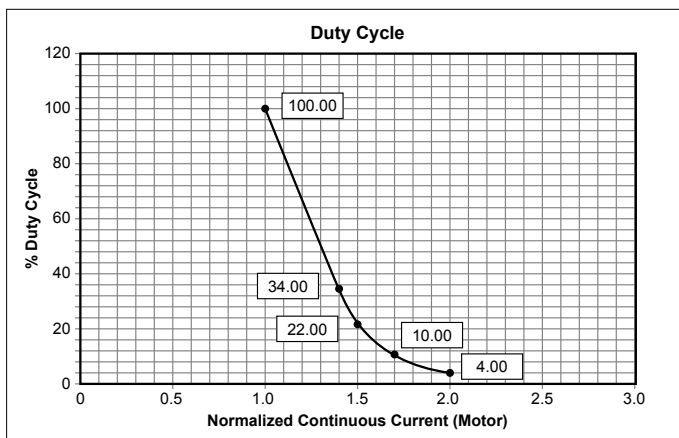

Figure 10 – Duty cycle for peak current operation

6.1 LUBRICATION

GTX Series actuators lubricated with grease require periodic inspection and renewal of the bearing and roller screw grease to maximize actuator life. Maintenance indicators during a physical inspection include:

- Contamination of grease with foreign matter
- Leaking seals
- “Burnt” smell of the grease
- Grease is gritty in appearance
- Grease is dehydrated (dried out)

Although application-specific performance makes it difficult to provide an exact number of hours of operation before maintenance is required, the following factors will help determine lubrication maintenance cycles.

Temperature – Temperature is the most significant factor affecting grease life. Exlar’s testing of Mobil SHC 220 synthetic grease indicates ideal performance operation in ambient temperature ranging from 32° C to 55° C (90° F to 130° F). Within this temperature range, the grease has a long service life. Operation in temperatures above this range decreases the effective grease life. For every temperature rise of 15° C (60° F), grease life is reduced by approximately 50%.

Speed – The rotational speed of the actuator will generate heat (thus raising the grease temperature) and potentially resulting in lubricant being thrown off the roller screw.

Load – Load contributes to the stress applied to the roller screw mechanism and the pressure applied to the grease thus impacting the overall lubricant life and relubrication interval. Load directly impacts the amount of power put into the actuator adding to the heat generated by roller screw speed. This heat is transmitted to the lubricant eventually separating the oils from the thickener and reducing grease life.

Orientation – Gravity can cause grease migration over time, especially in vertical applications at elevated temperatures. Figure 11 provides a general guideline for recommended lubrication renewal cycles.

RMS Rotational Speed (RPM)	Recommended Grease Renewal Period (hours)		
	Case Temp. 65° C (149° F)	Case Temp. 80° C (176° F)	Case Temp. 95° C (203° F)
250	10,000	5,000	2,500
500	8,500	4,250	2,125
1000	6,000	3,000	1,500
1500+	3,500	1,750	875

Figure 11 – Recommended lubrication renewal cycles

Grease renewal procedure (refer to Figure 12)

1. Remove the four bolts connecting the faceplate and any mounting accessories from the front of the actuator.
2. Remove the roller screw by turning it counter clockwise and threading it out of the cylinder. To remove the screw, it may be necessary to hold the roller screw cylinder to keep it from turning. Turning the shaft will help force the faceplate assembly to break free of its housing.
3. Use a brush to work approximately 10 cm³ (0.6 in³) of grease into the roller screw assembly for every 100 mm (3.9 in) of stroke length. Be sure all the threaded surfaces of the screw assembly are covered. This can be accomplished by applying grease to a few places on the roller screw assembly and rotating the components repeatedly in both directions to work the grease into the assembly. **IMPORTANT!** Excess grease does not improve lubrication and requires greater torque when the motor is returned to operation.
4. With the actuator in the vertical position and the open end of the roller screw cylinder facing up, position the roller screw above the cylinder so that it is aligned axially with the roller screw cylinder.
5. Slowly turn the roller screw clockwise in ¼- to ½-turn increments while maintaining contact with the interior threaded cylinder (ITC). This helps align the threads on the roller screw with the threads in the ITC. Do NOT force the roller screw into the cylinder.

If the roller screw does not turn freely, remove it and begin again. When the screw is properly threaded into the cylinder, it will roll freely into the actuator. **NOTE:** When the roller screw reaches the portion of the cylinder that contains the motor magnets, it will be more difficult to turn because of the magnetic field of the magnets. THIS IS NORMAL. Continue to thread the roller screw into the cylinder until it reaches the bottom (it will become difficult to turn and the motor and bearings will begin to rotate with it).

6. Place a small amount of seal lubricant on the inside surface of the seal/bushing assembly.
7. Carefully slide the faceplate over the actuator rod end while guiding the four cap screws through their respective holes in the rear end cap of the actuator. Ensure the faceplate seats completely and squarely on the front of the actuator.

NOTE: The seal is a tight fit on the rod end. Use caution to avoid damaging the seal on the threads of the extending rod. The inner surface of the faceplate provides the pre-loading for the bearings, so it is important that it be properly seated. Torque the four cap screws of the faceplate assembly to 12.2 Nm (9 ft-lb).

8. For actuators equipped with an external anti-rotate mechanism and/or limit switch assembly, slide the rod of the anti-rotate mechanism rod into the guide bushing. Tighten the two screws used to hold the anti-rotate assembly or the four screws used by the limit switch assembly to clamp that assembly to the actuator rod.

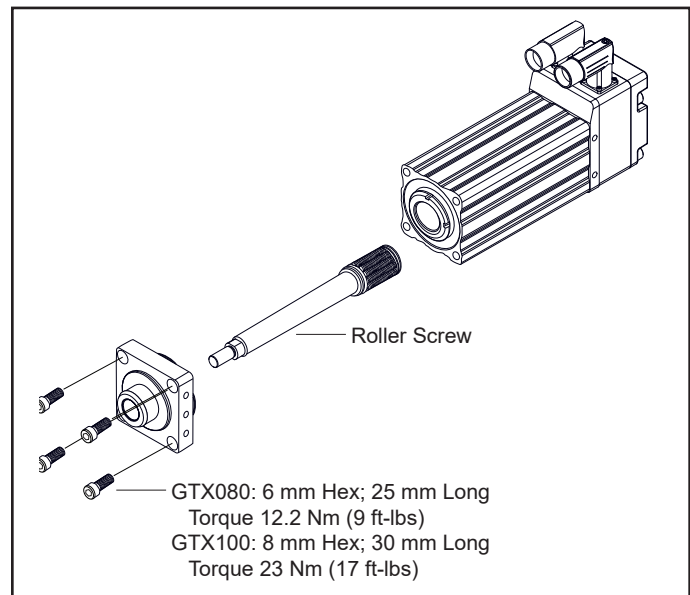

Figure 12 – Grease renewal reference

6.2 SEAL MAINTENANCE

Exlar recommends that the faceplate assembly containing the main rod seal and bushing assembly be replaced during the re-lubricating procedure. To have this service performed for you, contact the Exlar Returns Department to send your unit in for service (see Section 8.0, “Product Returns”). If any additional maintenance or repair is needed, consult Exlar. It may be necessary to return the actuator to the factory for refurbishment.

6.3 REPLACEMENT FACEPLATE ASSEMBLY KIT

Faceplate	Model	Part Number	Parts Included
	GTX080	PN 71457	Faceplate, O-ring, bushing, seal, wiper, and fasteners
	GTX100	PN 75536	

Figure 13 – Faceplate Assembly Kit

7.0 TROUBLESHOOTING

GTX Series actuators are engineered for years of trouble-free operation. If problems are encountered while installing or using the actuator, the information in Figure 14 may help solve the problem.

Symptom / Trouble	Possible Cause / Troubleshooting Procedure
No response from actuator.	<ul style="list-style-type: none"> • Ensure the amplifier is enabled. • Check amplifier for faults that may indicate problem. • Check for proper wiring.
Actuator seems to be enabled (receiving current) but is not operating or is operating erratically.	<ul style="list-style-type: none"> • Amplifier may be improperly tuned. Check all gain settings. If a motor file or parameters specific to your amplifier/actuator combination have been supplied by Exlar, be sure that they are entered or downloaded properly. • Amplifier may be set up improperly for the particular motor being used. Check amplifier settings for number of poles, voltage, current, resistance, inductance, inertia, etc. • Feedback wiring may be incorrect. • Feedback conductors are touching, or feedback cable may be damaged. • Motor phases are wired incorrectly or in incorrect order (R,S,T). • Feedback (resolver or encoder) is improperly aligned. Contact Exlar.
Actuator cannot move load.	<ul style="list-style-type: none"> • Load is too large for the capacity of the actuator or too much friction is present. • Excessive side load. • Misalignment of output rod to load. • Amplifier has too low of current capacity or is limited to too low of current capacity.
Actuator housing moves or vibrates when shaft is in motion.	<ul style="list-style-type: none"> • Check actuator mounting. Ensure that the actuator is securely mounted. • Amplifier is improperly tuned (wrong gain settings). Re-tune amplifier.
Output rod rotates during motion and thus does not provide proper linear motion.	<ul style="list-style-type: none"> • Install Exlar anti-rotation assembly or incorporate anti-rotation into the application.
Limit switches not functioning.	<ul style="list-style-type: none"> • Limit switches are wired improperly. Refer to manual. • The device being driven by the limit switches is not compatible with the electrical output of the limit switch. Check device requirements. • Switches have been damaged by improper wiring or improper voltage applied. Replace switches.
Brake does not hold load in place.	<ul style="list-style-type: none"> • Load is larger than the capacity of the brake-check load level against actuator rating. • Brake is not engaged. (Power is not removed, or only partially removed from brake). • Brake is being used as other than a power-loss holding brake.
Actuator is overheating.	<ul style="list-style-type: none"> • Insufficient cooling for application requirements. • Actuator is being operated outside of continuous ratings. • Amplifier is poorly tuned causing excessive unnecessary current to be applied to motor. Check gain settings.

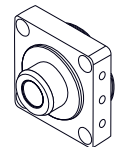
Figure 14 – Troubleshooting guidelines

8.0 PRODUCT RETURNS

Procedure to return products for repair or replacement:

1. Before requesting an RGA number, please contact Exlar Technical Support to see if it is possible to resolve the issue prior to return.
2. If it is determined that an RGA number is required, please do so by completing an online RGA request form found on the Exlar website. For international repairs, closely follow instructions provided by the Exlar Returned Goods Administrator. Failure to comply with issued instructions may result in delays for repair and return.

9.0 CERTIFICATIONS

CERTIFICATE OF COMPLIANCE

Certificate Number 20190906-E225288
Report Reference E225288-20171030
Issue Date 2019-SEPTEMBER-06

Issued to: EXLAR CORP
18400 W 77TH ST
CHANHASSEN MN 55317

This certificate confirms that representative samples of

COMPONENT - SERVO AND STEPPER MOTORS
See next page for models

Have been investigated by UL in accordance with the component requirements in the Standard(s) indicated on this Certificate. UL Recognized components are incomplete in certain constructional features or restricted in performance capabilities and are intended for installation in complete equipment submitted for investigation to UL LLC.

Standard(s) for Safety: UL 1004-1, Rotating Electrical Machines – General Requirements
UL 1004-6, Servo and Stepper Motors
CSA C22.2 No. 100, Motors and Generators

Additional Information: See the UL Online Certifications Directory at <https://iq.ulprospector.com> for additional information.

This Certificate of Compliance does not provide authorization to apply the UL Recognized Component Mark. Only the UL Follow-Up Services Procedure provides authorization to apply the UL Mark.
Only those products bearing the UL Recognized Component Mark should be considered as being UL Certified and covered under UL's Follow-Up Services.
Look for the UL Recognized Component Mark on the product.

Exlar
UL LLC
UL

Page 1 of 2

CERTIFICATE OF COMPLIANCE

Certificate Number 20190906-E225288
Report Reference E225288-20171030
Issue Date 2019-SEPTEMBER-06

This is to certify that representative samples of the product as specified on this certificate were tested according to the current UL requirements.

Class H Insulated Servo motors, models
GTXX080-###-#X-#-##-###-##-##-##
GTXX080-###-#C-#-##-###-##-##-##
GTXX100-###-#X-#-##-###-##-##-##

*X – indicated stator winding code, maybe any alphanumeric character except D.
*# – Represents a single alphanumeric character, indicating exterior mechanical, shaft/thread, and cosmetic configurations.

Exlar
UL LLC
UL

Page 2 of 2

EU Declaration of Conformity

This declaration is issued under the sole responsibility of the manufacturer.

The undersigned, representing the
Manufacturer
Exlar Corporation
18400 West 77th Street
Chanhasseen, MN 55317 USA

and the authorized representative
established within the community
Exlar GmbH
Frankfurter Str: 107
65479 Raunheim, Germany

Declares, that the Exlar Brand Products:
GTX Linear Actuators

(Complete Model Listing Below)
Model identification:
GTX080

The objects of the declaration described above is in conformity with the relevant Union harmonization legislation.

Per directives listed below:
*EU EMC Directive 2014/30/EU
EU Low Voltage Directive 2014/35/EU
EU RoHS 2011/65/EU and amended with Directive 2015/863*

Using the relevant section of the following EU standards and other normative documents:

EMC: EN 55014-1:2017
EN 55014-2:2015
Safety: IEC/EN 60034-1:2010
Year of CE Marking: 2018

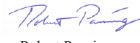
Signature: 
Name: Robert Panning
Position: Manager Product Development, Engineering
Date of Issue: June 11th, 2018

EU Declaration of Conformity

This declaration is issued under the sole responsibility of the manufacturer.

*The undersigned, representing the
Manufacturer
Exlar Corporation
18400 West 77th Street
Chanhassen, MN 55317 USA*

*and the authorized representative
established within the community
Exlar GmbH
Frankfurter Str.: 107
65479 Raunheim, Germany*

*Declares, that the Exlar Brand Products:
GTX Linear Actuators*

*(Complete Model Listing Below)
Model identification:
GTX100*

*The objects of the declaration described above is in conformity with the relevant
Union harmonization legislation.*

Per directives listed below:

*EU EMC Directive 2014/30/EU
EU Low Voltage Directive 2014/35/EU
EU RoHS Directive 2011/65/EU and Directive 2015/863*

Using the relevant section of the following EU standards and other normative documents:

*EMC: EN 55014-1:2017
EN 55014-2:2015*

Safety: IEC/EN 60034-1:2010

Year of CE Marking: 2019

Signature:

Name: Robert Panning
Position: Manager Product Development, Engineering
Date of Issue: Dec 2nd, 2019



NOTE: GTX Series actuators that are intended as components in a third-party machine in which the enclosure and assembly will affect the EMC emissions, are covered by the EMC standard that relates to the final product.

Per EU directives implemented on April 20th, 2016, the following procedures must be followed by importers and distributors.

9.1 IMPORTER REQUIREMENTS

- Importers shall indicate their name, registered trade name or registered trade mark, and the postal address at which they can be contacted on the apparatus (unless that is not possible, in which case it should be included on the packaging or in an accompanying document).
- Importers shall ensure that the product is accompanied by instructions and safety information in a language which can be easily understood by end-users, as determined by the Member State concerned.

- Importer is to translate the EU declaration of conformity into the languages required by the member state(s), where the product is sold. Importers shall keep a copy of the EU declaration of conformity for 10 years.
- Importers shall provide a reasoned request from a competent national authority and provide it with all the information and documentation in paper or electronic form necessary to demonstrate the conformity of a product in a language which can be easily understood by that authority.
- Importers shall ensure that, while apparatus is under their responsibility, its storage or transport conditions do not jeopardize its compliance with the safety objectives.
- Importer shall take corrective action necessary when they consider or have reason to believe that the product is not in conformity with its directive(s).

9.2 DISTRIBUTOR REQUIREMENTS

- Distributors shall indicate their name, registered trade name or registered trade mark and the postal address at which they can be contacted on the apparatus (unless that is not possible, in which case it should be included on the packaging or in an accompanying document).
- Distributor shall ensure that apparatus is accompanied by instructions and safety information in an appropriate language. Distributor shall translate the EU declaration of conformity into the languages required by the member state(s), where the product is sold. Distributors shall keep a copy of the EU declaration of conformity for 10 years.
- Distributor shall ensure that, while apparatus is under their responsibility, its storage or transport conditions do not jeopardize its compliance with the safety objectives.
- Distributor shall take corrective action necessary when they consider or have reason to believe that the product is not in conformity with its directive(s).

10.0 WARRANTY AND LIMITATION OF LIABILITY

Products are warranted for two years from date of manufacture as determined by the serial number on the product label. Labels are generated and applied to the product at the time of shipment. The first and second digits are the year and the third and fourth digits represent the manufacturing week. Product repairs are warranted for 90 days from the date of the repair. The date of repair is recorded and tracked by individual product serial number.

Exlar Corporation (“Exlar”) warrants its product(s) to the original purchaser and, in the case of original equipment manufacturers, to their original customer, to be free from defects in material and workmanship and to be made only in accordance with Exlar’s standard published catalog specifications for the product(s) as published at the time of purchase. Warranty or performance to any other specifications is not covered by this warranty unless otherwise agreed to in writing by Exlar and documented as part of any and all contracts, including but not limited to purchase orders, sales orders, order confirmations, purchase contracts and purchase agreements. In no event shall Exlar be liable or have any responsibility under such warranty if the product(s) has been improperly stored, installed, used or maintained, or if Buyer has permitted any unauthorized modifications, adjustments and/or repairs to such product(s). Seller’s obligation hereunder is limited solely to repairing or replacing (at its opinion), at the factory any product(s), or parts thereof, which prove to Seller’s satisfaction to be defective as a result of defective materials, or workmanship and within the period of time, in accordance with the Seller’s stated product warranty (see Terms and Conditions, above), provided, however, that written notice of claimed defects shall have been given to Exlar within thirty (30) days from the date of any such defect is first discovered. The product(s) claimed to be defective must be returned to Exlar, transportation prepaid by Buyer, with written specification of the claimed defect. Evidence acceptable to Exlar must be furnished that the claimed defects were not caused by misuse, abuse, or neglect by anyone other than Exlar.

Components such as seals, wipers, bearings, brakes, bushings, gears, splines, and roller screw parts are considered wear parts and must be inspected and serviced on a regular basis. Any damage caused by failure to properly lubricate Exlar products and/or to replace wear parts at appropriate times, is not covered by this warranty. Any damage due to excessive loading is not covered by this warranty.

The use of products or components under load such that they reach the end of their expected life is a normal characteristic of the application of mechanical products. Reaching the end of a product’s expected life does not indicate any defect in material or workmanship and is not covered by this warranty.

Costs for shipment of units returned to the factory for warranty repairs are the responsibility of the owner of the product. Exlar will return ship all warranty repairs or replacements via UPS Ground at no cost to the customer.

For international customers, Exlar will return ship warranty repairs or replacements via UPS Expedited Service and cover the associated shipping costs. Any VAT or local country taxes are the responsibility of the owner of the product.

The foregoing warranty is in lieu of all other warranties (except as Title), whether expressed or implied, including without limitation, any warranty of merchantability, or of fitness for any particular purpose, other than as expressly set forth and to the extent specified herein, and is in lieu of all other obligations or liabilities on the part of Exlar.

Seller’s maximum liability with respect to these terms and conditions and any resulting sale, arising from any cause whatsoever, including without limitation, breach of contract or negligence, shall not exceed the price specified herein of the product(s) giving rise to the claim, and in no event shall Exlar be liable under this warranty otherwise for special, incidental or consequential damages, whether similar or dissimilar, of any nature arising or resulting from the purchase, installation, removal, repair, operation, use or breakdown of the product(s) or any other cause whatsoever, including negligence.

The foregoing warranty shall also apply to products or parts which have been repaired or replaced pursuant to such warranty, and within the period of time, in accordance with Seller’s stated warranty.

NO PERSON, INCLUDING ANY AGENT OR REPRESENTATIVE OF EXLAR, IS AUTHORIZED TO MAKE ANY REPRESENTATION OR WARRANTY ON BEHALF OF EXLAR CONCERNING ANY PRODUCTS MANUFACTURED BY EXLAR, EXCEPT TO REFER PURCHASERS TO THIS WARRANTY.

About Curtiss-Wright Commercial / Industrial Segment

Curtiss-Wright provides highly engineered products and services with a focus on advanced technologies for high performance platforms and critical applications. Our technological expertise spans decades of innovation and we have compiled an extensive portfolio of critical technologies serving commercial, defense, energy and industrial markets. Our technologies, some that are sole source or first-of-a-kind, achieve the demanding performance levels required for optimal safety, performance and reliability in difficult “must not fail” applications.

USA – EXLAR AUTOMATION
Curtiss-Wright

18400 West 77th Street
Chanhassen, MN 55317
Phone: 855-620-6200 (US & Canada)
Phone: 952-500-6200
Email: CHA_info@curtisswright.com
Website: www.exlar.com

EUROPE – EXLAR EUROPE GmbH
Curtiss-Wright

Schleißheimer Str., 91a
Garching bei München D-85748
Germany
Phone: +49 6184 994730
Email: info@exlar.de
Website: www.exlar.com/de/

ASIA – EXLAR ASIA PACIFIC
Curtiss-Wright

1007 Pine City Hotel
8 Dong An Road, Xuhui District
Shanghai 200032 China
Phone: +86 021-6495-7868
Email: mfan@curtisswright.cn
Website: www.exlar.com/zh-hans/