

MLE 3 linear motor stages

Technical Description

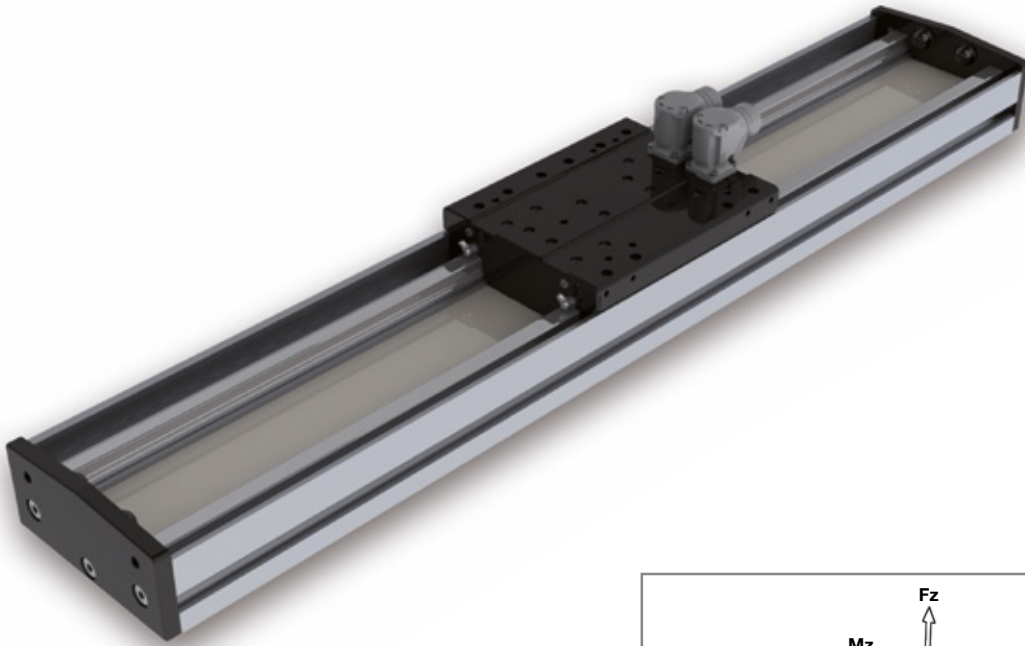

Repeatability of measuring system: $\pm 1 \mu\text{m}$
 Repeatability linear unit: $\pm 5 \mu\text{m}$
 Maximum speed: 9 m/s
 Maximum acceleration: 110 m/s²
 Maximum Length without joints: up to 3.600 mm
 Operating voltage: 600Vdc
 Max. Operating voltage: 900Vdc

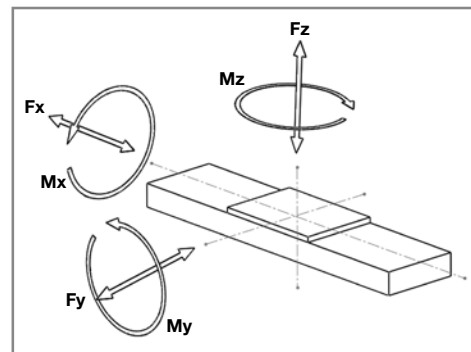

Mechanical specifications

Linear motor stage		MLE 30105	MLE 30210		MLE 30420		
Carriage typ		R	S	R	S	R	
Linear motor features							
Maximum speed ¹⁾	m/s		3				
Continuous force aircooled ²⁾	N	55	105		210		
Peak force	N	105	210		420		
Nominal current	A	1,5	3,0		6,0		
Peak current	A	3,1	6,2		12,4		
Guidance features							
F _y	N	1500	1500	1500	1500	1500	
F _z	N	1000	1000	1000	1000	1000	
M _x	Nm	180	180	180	180	180	
M _y	Nm	280	280	320	320	400	
M _z	Nm	280	280	320	320	400	
For the sum of all forces and moments:			$\frac{F_{ye}}{F_y} + \frac{F_{ze}}{F_z} + \frac{M_{xe}}{M_x} + \frac{M_{ye}}{M_y} + \frac{M_{ze}}{M_z} < 1$			(X _e = calculated value) (X _x = max. catalogue value)	
Structure profile features							
Geometrical moments of inertia L _x	mm ⁴		3,72x10 ⁵				
Geometrical moments of inertia L _y	mm ⁴		55,58x10 ⁵				
Elastic module	N/mm ²		70000				
Weight							
Weight of carriage	kg	2,2	2,9	3,1	3,8	4,1	
Weight of 100 mm	kg		1,2				

¹⁾ for a lifetime > 30.000 Km

²⁾ depending on the application and ambient temperature

Dimensions MLE 3

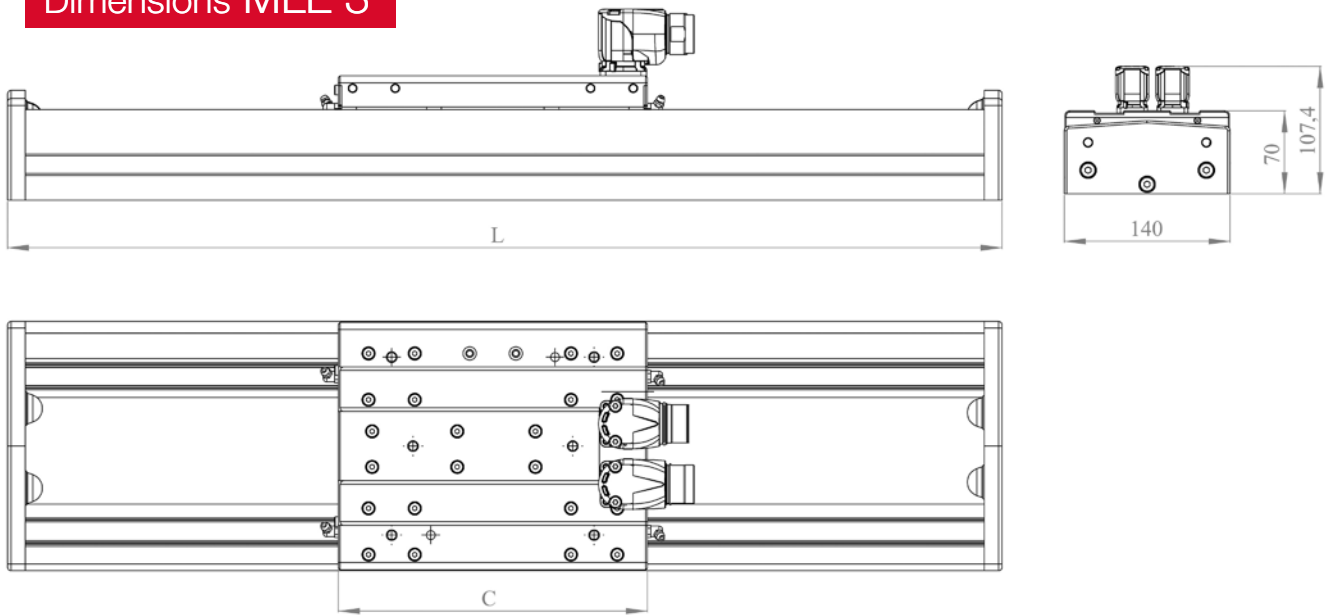

Drawing for reference only. Please ask for ready 3D files.

Choice of stroke

Linear motor stage	MLE 30105		MLE 30210		MLE 30420	
Carriage typ	R		S	R	S	R
Carriage length C, mm	182		182	272	272	350
Length, mm	Code	Stroke ⁽¹⁾				
368	00368	146	146	56	56	-
416	00416	194	194	104	104	26
512	00512	290	290	200	200	122
560	00560	338	338	248	248	170
608	00608	386	386	296	296	218
656	00656	434	434	344	344	266
704	00704	482	482	392	392	314
752	00752	530	530	440	440	362
800	00800	578	578	488	488	410
896	00896	674	674	584	584	506
944	00944	722	722	632	632	554
1088	01088	866	866	776	776	698
1184	01184	962	962	872	872	794
1328	01328	1106	1106	1016	1016	938
1472	01472	1250	1250	1160	1160	1082
1568	01568	1346	1346	1256	1256	1178
1712	01712	1490	1490	1400	1400	1322
1856	01856	1634	1634	1544	1544	1466
1952	01952	1730	1730	1640	1640	1562
2096	02096	1874	1874	1784	1784	1706
2240	02240	2018	2018	1928	1928	1850
2336	02336	2114	2114	2024	2024	1946
2480	02480	2258	2258	2168	2168	2090
2624	02624	2402	2402	2312	2312	2234
2720	02720	2498	2498	2408	2408	2330
2864	02864	2642	2642	2552	2552	2474
3008	03008	2786	2786	2696	2696	2618
3104	03104	2882	2882	2792	2792	2714
3248	03248	3026	3026	2936	2936	2858
3392	03392	3170	3170	3080	3080	3002
3488	03488	3266	3266	3176	3176	3098

¹⁾ Other stroke lengths are available under request

MLE 3 Options

Connector Options

■ straight connectors M23, up (0)



■ angled connectors 90° M23 (1)



■ side connectors M23 (30)



■ side connectors M23, down (31)



■ side connectors M23, up (32)



■ side connectors, hybrid (33)



■ cable output with connectors M23 (4)



■ cable output without connectors (5)



■ cable output with connectors YTEC (6)



Cover Options

■ open version (0)

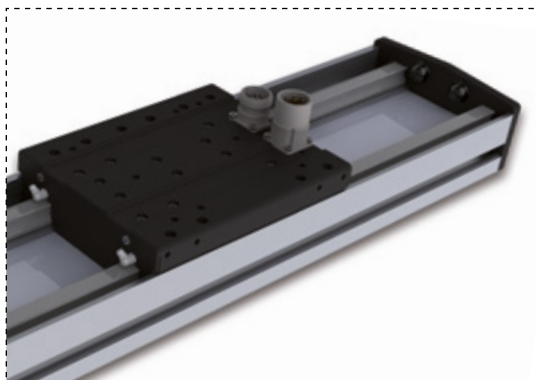

■ cover version (1)



Order Code MLE 3

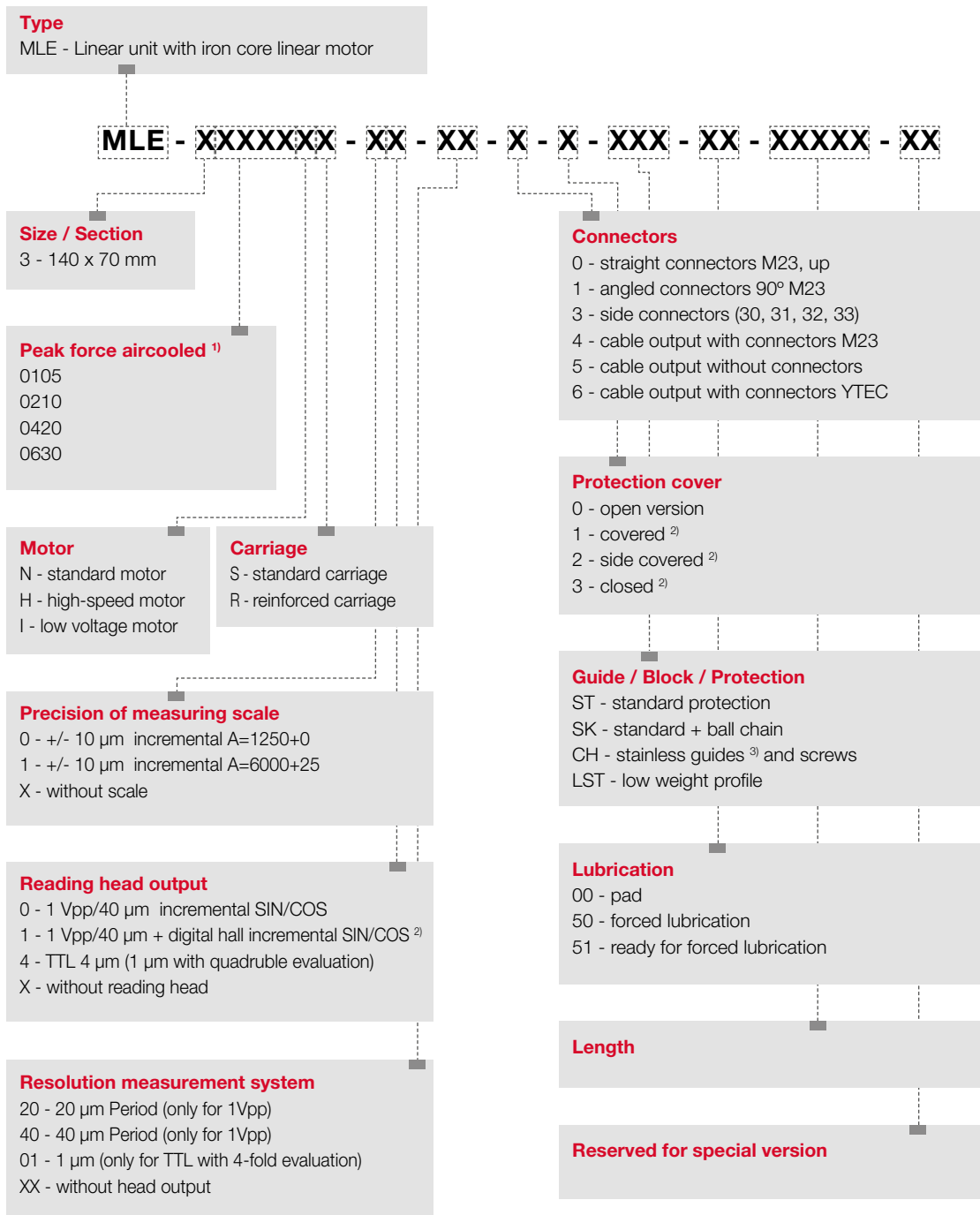

⁽¹⁾ Depends on application and temperature

⁽²⁾ On request