

# TECNOTION<sup>®</sup>

direct drive in motion



Frameless torque motor series



# WE DIRECT DRIVE YOUR MOTION TECHNOLOGY

**Tecnotion is the global authority on direct drive motor technology. We are the world's only unbundled manufacturer of linear and torque motors. As a former part of Philips, we specialize solely in the development and production of linear and torque motors. Because of this, our expertise, customer service and product quality are unmatched.**

We have a global presence, with production plants in the Netherlands and China and local representation around the world. This ensures short delivery times and high quality support, wherever you are located.

When you do business with Tecnotion, you have a team of highly skilled sales and application engineers at your disposal. They help you from your initial prototype all the way to the application of our products and beyond.

## Sales support

At Tecnotion we understand that each application of our motors is a unique case with specific requirements and demands.

Our sales and application engineers have extensive experience with a wide range of application types and collaborate on a high level with our customers to make sure you get the solution that best fits your requirements.

Additionally our specialized simulation tool is available to help you find your way through our wide range of motors and analyze/test out different motor types within your application specifications.



## Innovation

We have an in-house R&D department, which is continuously pushing the boundaries of technology and taking our products to the next level. This translates directly to our high level of understanding of manufacturing processes.

Apart from our "off-the-shelf" range of standard motors, we can also design and manufacture custom made motors for high profile projects or OEM applications that require a tailor-made solution.

All our custom motors are built to the same high standards that characterize our standard range of products.



## Manufacturing

Manufacturing of our standard range of motors takes place at our modern plant in China, where we are able to produce in high volume at very competitive rates.

At our competence centre and headquarters in the Netherlands we specialize in advanced technology. This is where we do our research and development and where custom motors are built with extreme accuracy in our special state of the art clean room environment.

Tecnotion is committed to excellence. Both of our plants are ISO 9001 certified and comply to the highest quality standards possible.



## Global logistics

We always have our most popular products in stock in our warehouses in both the Netherlands and China.

Our logistics department can ship to you from both locations, making short delivery times possible across the globe, even when markets are ramping.



# Frameless torque motor series



See P.12

## QTR 65 and 78 series

The QTR 65 and 78 are the smallest motors from our torque range. The largest QTR 78-60 motor offers an ultimate torque of 10.85 Nm. Compact sizing and low voltage support makes the QTR 65 motor ideal for robotics applications. Small build-space and a large 29 mm inner diameter make the QTR 78 motor a favorite in semiconductor machinery. To provide maximum flexibility and integration the motor is equipped with flying leads instead of a power cable.

These motor series comes in two diameters: 65 and 78 mm and four heights: 17, 25, 34 and 60 mm.



See P.16

## QTR 105-133-160 series

Our medium range motors are available with a range of options. Different winding types are available, optimizing back EMF. A digital Hall sensor can be used as a 'wake and shake' replacement, simplifying the startup of the QTR motor. The largest QTR 160-60 motor, excels with 91.6 Nm ultimate torque. Various applications such as in medical, testing equipment, and factory automation benefit from the large inner diameter and the high peak torque of the series.

These motor series comes in three diameters: 105, 133 and 160 mm and four heights: 17, 25, 34 and 60 mm.



See P.22

## QTL 210-230-290-310-385-485 series

The QTL motor series are our largest torque motors up to date, yet very compact for the generated torque. The QTL is frameless as all our QTR motors and therefore it can be integrated directly into the machine structure, while the spacious open inner diameter enables wire and cable feed through. The series are suitable for a variety of markets including rotary indexing tables, printing machinery and materials handling. Available with (QTL 230, 310, 385 and 485) or without cooling ring (QTL 210 and 290). The QTL motor series comes in six diameters (210, 230, 290, 310, 385 and 485 mm) and three heights (65, 85 and 105 mm) for 210 - 310 and two heights (85 and 105 mm) for 385-485.

QTR-A	105	17	N
-------	-----	----	---

QTR/QTL-A = Torque (A = rotor options)  
 105 = Series type/outer diameter  
 17 = Motor height  
 N = Winding type

# Motor torque range

Ultimate torque Continuous torque

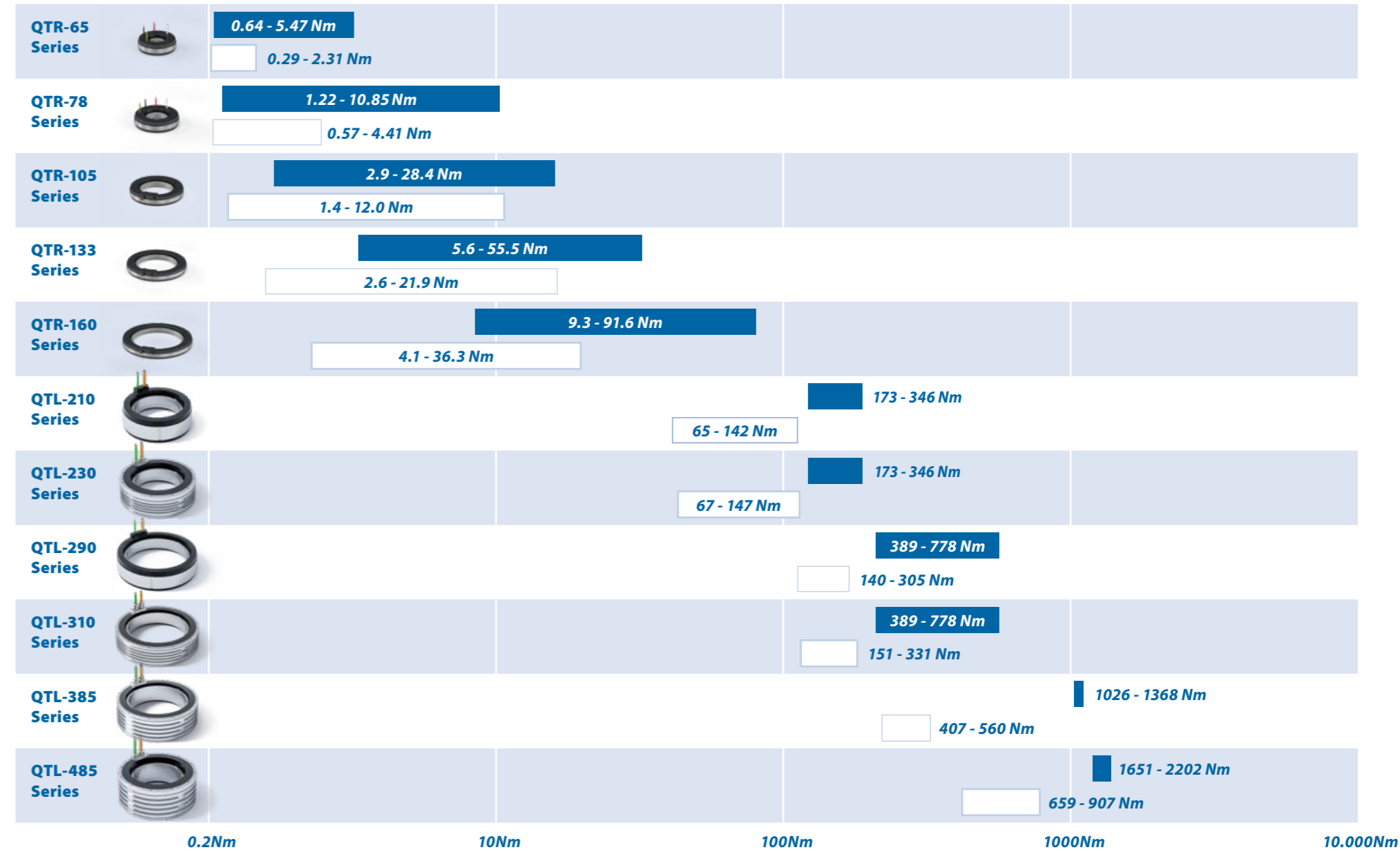

Torque QTR motor series  
**Properties QTR 65 and 78**

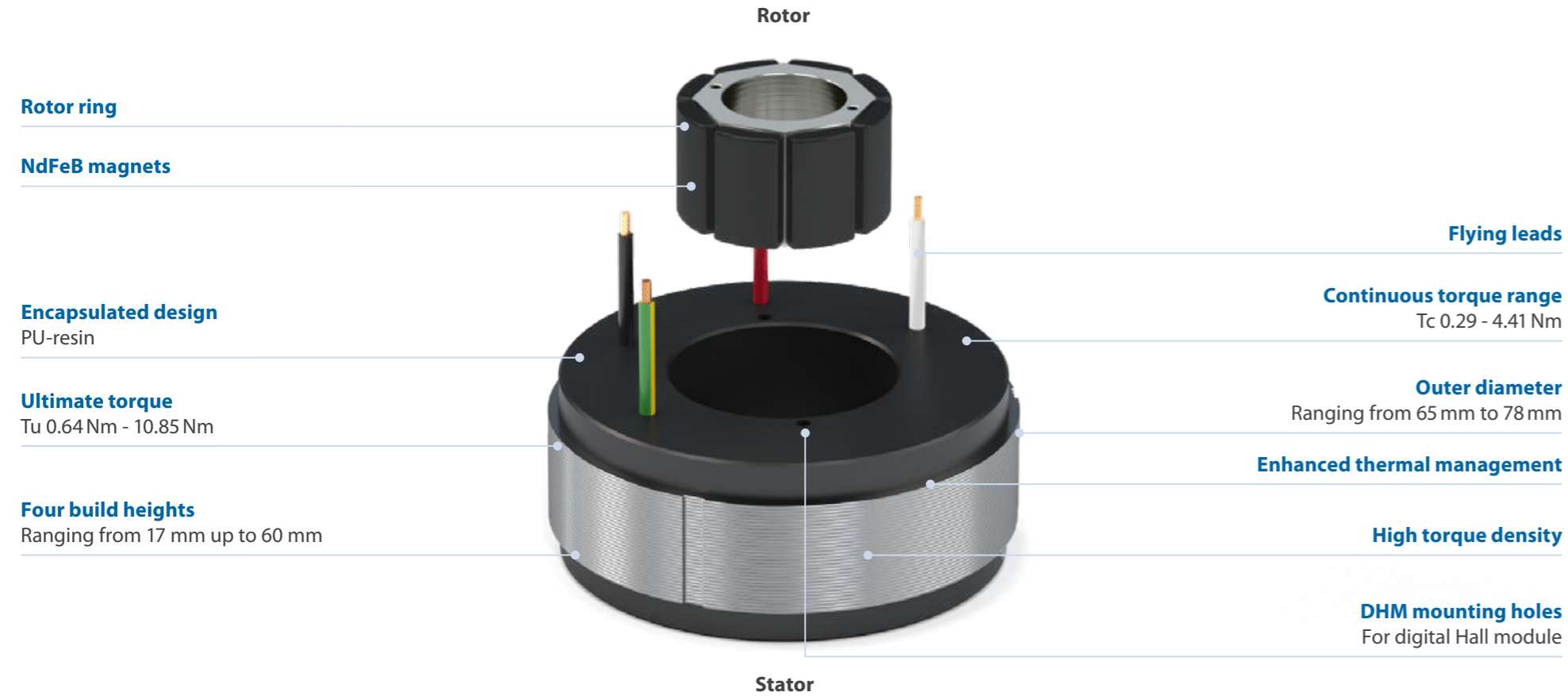

Torque QTR motor series  
**Properties QTR 105, 133 and 160**

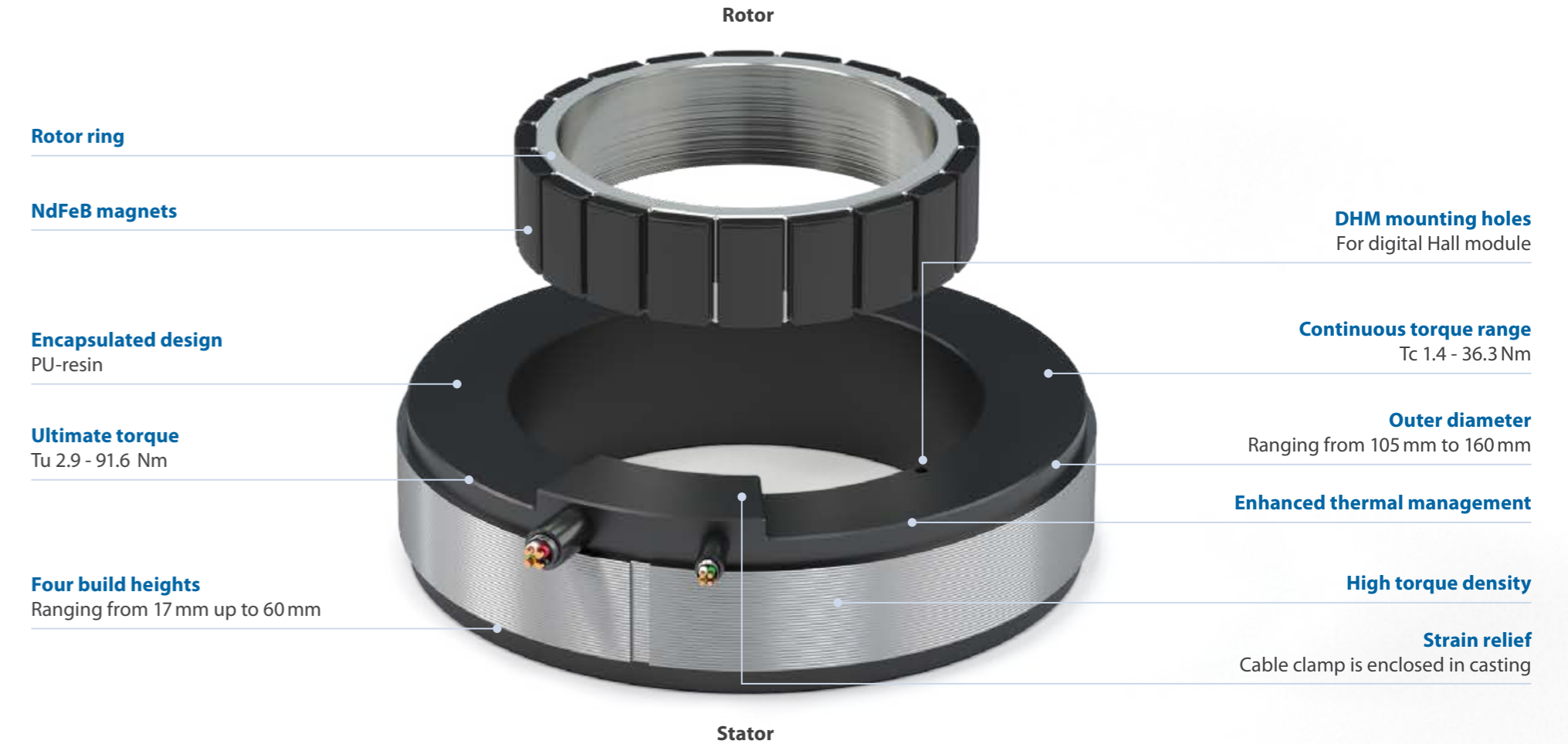

Torque QTL motor series  
**Properties QTL 210 and 290**

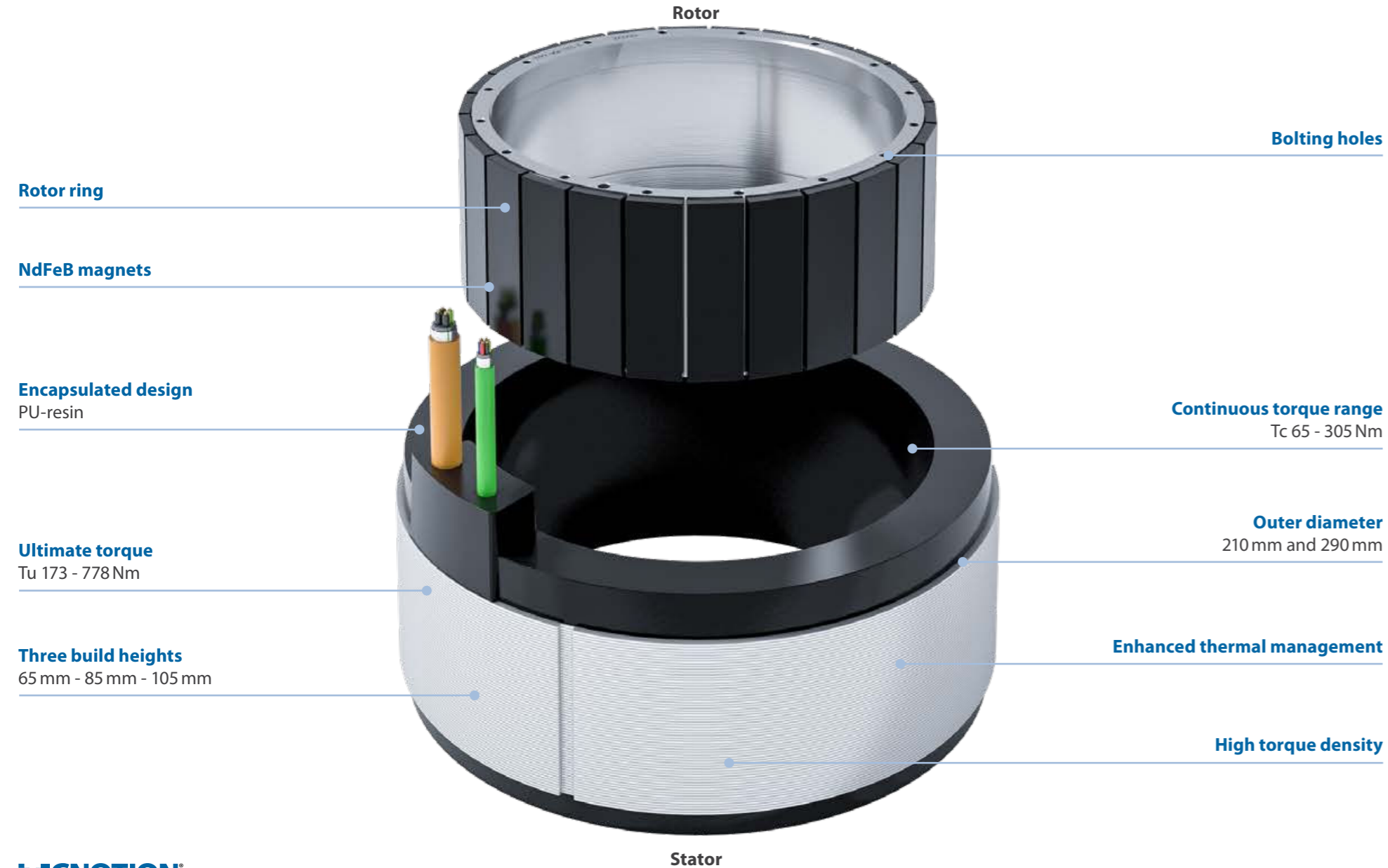

Torque QTL motor series with cooling ring  
**Properties QTL 230, 310, 385 and 485**

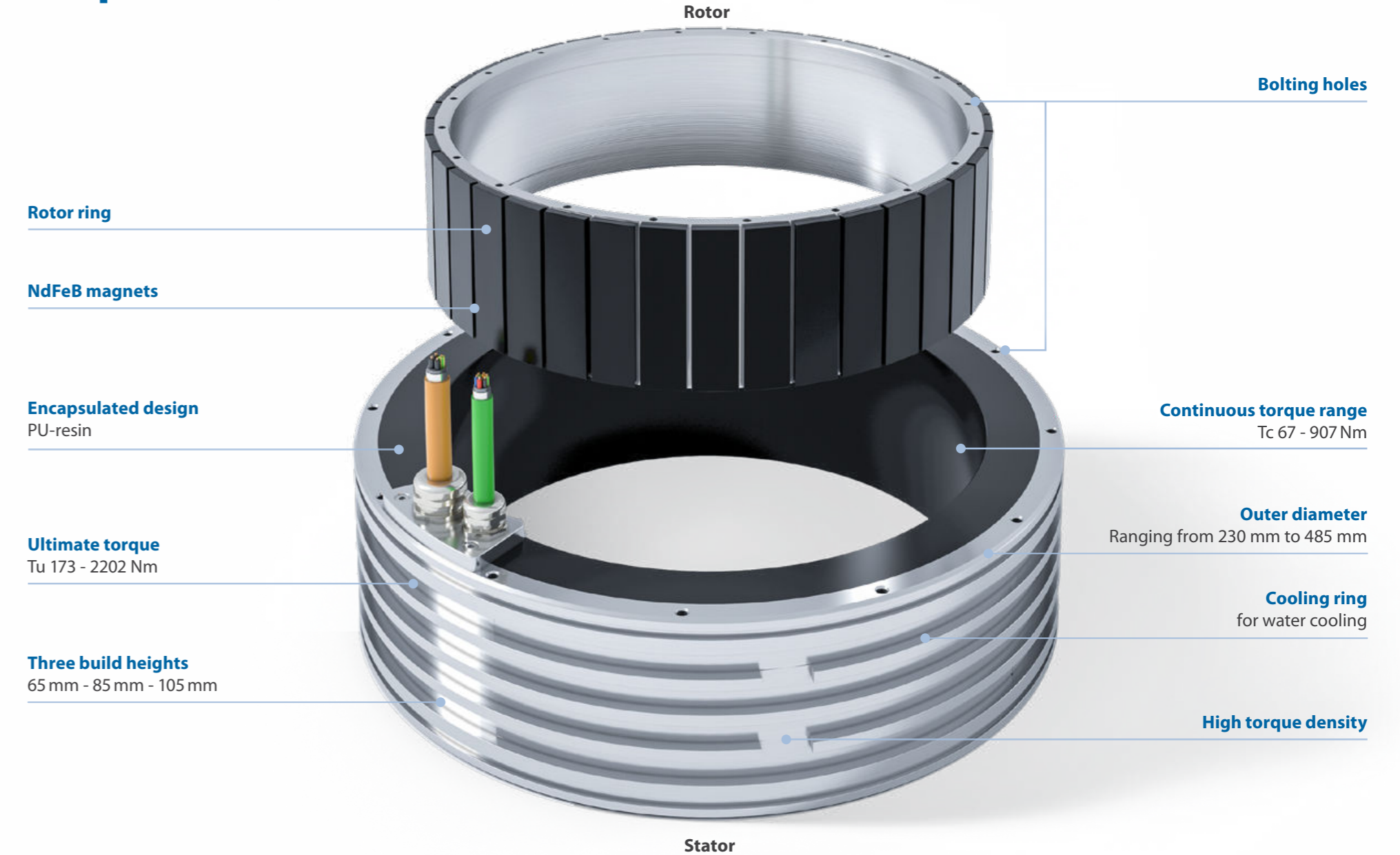

## Features

# Tecnotion's torque motor performance advantages

The direct drive technology of brushless torque motors is a perfect way to enhance productivity, accuracy, and dynamic performance of applications. The technology lowers costs, makes designs slimmer, and reduce wear and tear. Torque motors eliminate the need for mechanical transmissions like gearboxes, belts and speed reducers. Between rotor and stator there is no contact, this means no mechanical wear.



### Direct drive

Higher stiffness no backlash.

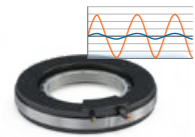

### Low cogging value, low total harmonic distortion (THD)

For smooth motion and position accuracy in your application.



### Large inner diameter

Allows easy integration of a large number of cables and hoses or allows large shaft fittings.



### Ultra thin design

The lower build height allows to build a flatter axis, resulting in less tipping and settling time. Extraordinary flexibility in designing the motor into small spaces.



### Encapsulated design

No open coil wires which can be damaged or that need to be covered up for safety reasons.



### High voltage insulated, up to 300 VDC/600 VDC bus voltage

Enabling the use of a wide range of servo drives, and power supplies.



### Tecnotion QTR has the highest torque density in the market

More torque in a smaller packing means lowering footprint.



### Shielded cable with strain relief

No shielding EMC issues with loose wires. No risk to damage the motor by accidentally pulling the cable.



### Good product repeatability

All motors have specifications with extremely little variation between them.



### Low thermal resistance

Allowing good heat transfer, achieving an extremely high continuous torque when using a decent size heatsink or active cooling.



### Low stator and rotor mass

Lower masses increase the dynamics and response of the system by lowering the inertia. It hands the opportunity to improve entire stage designs. And as a result, lowering an applications cost of ownership.



### 100% QC

All products are 100% mechanically and electrically tested.

## Torque QTR digital Hall module

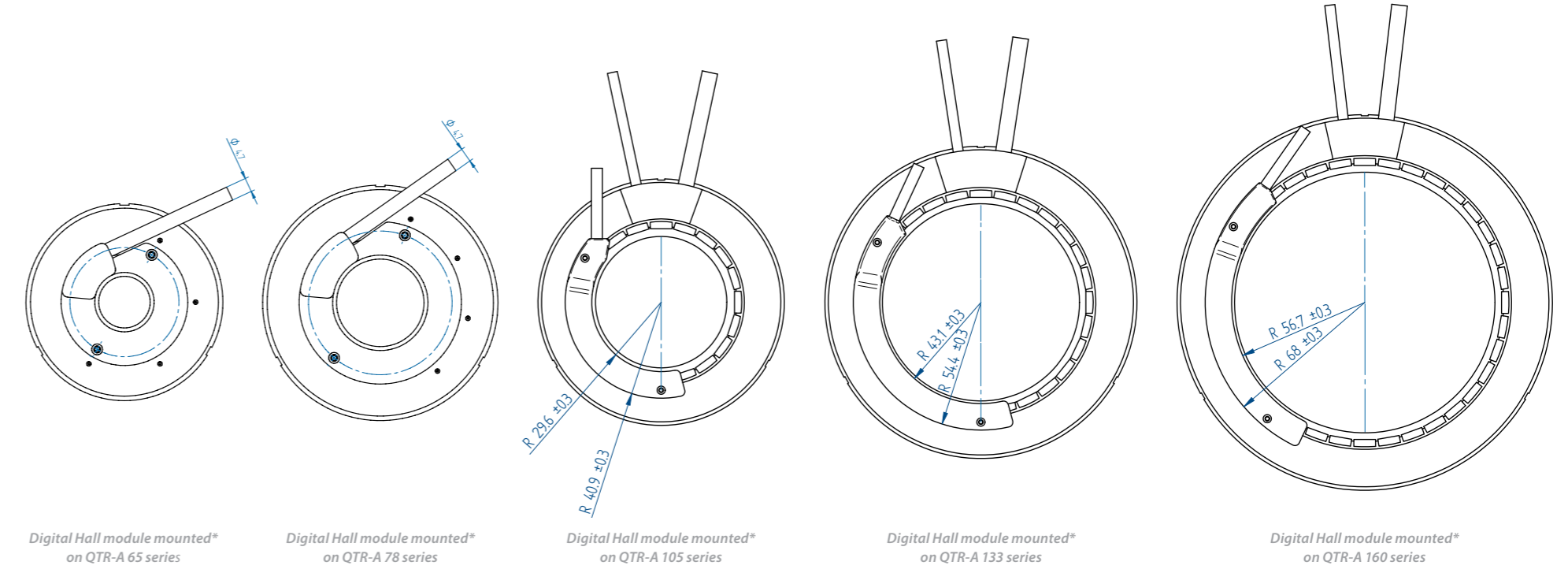

Digital Hall module mounted\* on QTR-A 65 series

Digital Hall module mounted\* on QTR-A 78 series

Digital Hall module mounted\* on QTR-A 105 series

Digital Hall module mounted\* on QTR-A 133 series

Digital Hall module mounted\* on QTR-A 160 series

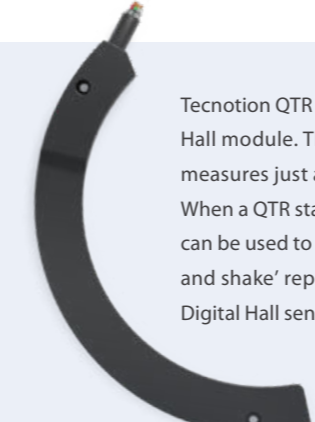

Tecnotion QTR motors can be equipped with a Tecnotion QTR digital Hall module. The module covers a small portion of the motor and measures just a little over 3 mm in thickness for the largest part. When a QTR stator is not powered the Tecnotion QTR digital Hall module can be used to determine the electrical position of the rotor. It is a 'wake and shake' replacement, simplifying the startup of the QTR motor. Digital Hall sensors are available for the QTR-A 65, 78, 105, 133 and 160 series.

### Specifications

**Input voltage:** 5V...15Vdc  
**Output voltage:** 3 phase TTL, max 2.5mA, 5Vdc  
 AquadB TTL, max 2.5mA, 5Vdc

\*Mounting instructions and tolerances can be found in the torque installation manual. Manuals and 3D CAD files can be downloaded from our website.

# Torque QTR 65 series



QTR-A 65 Stator and rotor shown with a height of 17 mm

Parameter	Remarks	Symbol	Unit	QTR-A 65-17	QTR-A 65-25	QTR-A 65-34	QTR-A 65-60
Winding type				N	N	Y	Y
Motor type max. voltage ph-ph	3-phase synchronous		$V_{ac rms} (V_{dc})$	420 (600)			
Ultimate torque @ 20°C/s increase	magnet @ 25°C	$T_u$	Nm	0.64	1.31	2.25	5.47
Peak torque @ 6°C/s increase	magnet @ 25°C	$T_p$	Nm	0.42	0.85	1.43	3.82
Continuous torque	coil @ 100°C	$T_c$	Nm	0.29	0.66	1.08	2.31
Maximum speed <sup>(3)</sup> @ 48 Volt	@ $T_c$	$n_{max}$	rpm	5735	2673	3456	910
Maximum speed <sup>(3)</sup> @ max. voltage	@ $T_c$	$n_{max}$	rpm	28000	28000	28000	16960
Motor torque constant	up to $I_c$	$K_t$	Nm/A <sub>rms</sub>	0.060	0.118	0.098	0.267
Motor constant	coils @ 25°C	$K_m$	(Nm) <sup>2</sup> /W	0.0021	0.0059	0.0111	0.0321
Ultimate current	magnet @ 25°C	$I_u$	A <sub>rms</sub>	13.84	13.84	27.98	24.99
Peak current	magnet @ 25°C	$I_p$	A <sub>rms</sub>	7.58	7.58	15.32	15.05
Maximum continuous current <sup>(1)</sup>	coils @ 100°C	$I_c$	A <sub>rms</sub>	4.86	5.61	11.07	8.65
Back EMF phase-phase <sub>peak</sub>		$K_e$	V/krpm	5.1	10.1	8.4	22.8
Back EMF phase-phase <sub>RMS</sub>		$K_e$	V/krpm	3.6	7.2	5.9	16.1
Coil resistance per phase	coils @ 25°C ex. cable	R	Ω	0.575	0.799	0.287	0.741
Coil induction per phase	$I < 0.6 I_p$	L	mH	0.86	1.62	0.69	2.10
Electrical time constant	coils @ 25°C	$\tau_e$	ms	1.5	2.0	2.4	2.8
Poles		$N_{mgn}$	nr	8	8	8	8
Continuous power loss	coils @ 100°C	$P_c$	W	53	99	138	217
Thermal resistance <sup>(2)</sup>	coils to mount. sfc.	$R_{th}$	°C/W	1.50	0.81	0.58	0.37
Thermal time constant	up to 63% max. coiltemp.	$\tau_{th}$	s	21	16	16	38
Temperature cut-off / sensor				No temperature sensor			
Stator OD		OD <sub>s</sub>	mm	65			
Rotor ID		ID <sub>R</sub>	mm	17			
Motor height		H <sub>motor</sub>	mm	18	26	35	62
Lamination stack height		H <sub>arm</sub>	mm	8	16	24	48
Rotor inertia		J <sub>R</sub>	kg*m <sup>2</sup>	3.8E-06	7.5E-06	1.1E-05	2.3E-05
Stator mass	excluding cables	M <sub>s</sub>	g	149	248	361	717
Rotor mass		M <sub>R</sub>	g	27	54	80	160
Total mass	excluding cables	M <sub>T</sub>	g	176	302	441	877
Cable mass	all cables	m	g	36			
Cable type (power)	length 0.5 m	d	mm (AWG)	2.06 (16)			

- These values are only applicable when the mounting surface is at 20°C and the motor is driven at maximum continuous current. If these values differ in your application, please check our simulation tool or manual.
- R<sub>th</sub> based on radial mounting of stator lamination stack.
- MAXIMUM allowable speed for QTR-A 65 series motors is 28.000 rpm. If you plan a high speed application, please contact Tecnotion.

All specifications ±10%

Stator

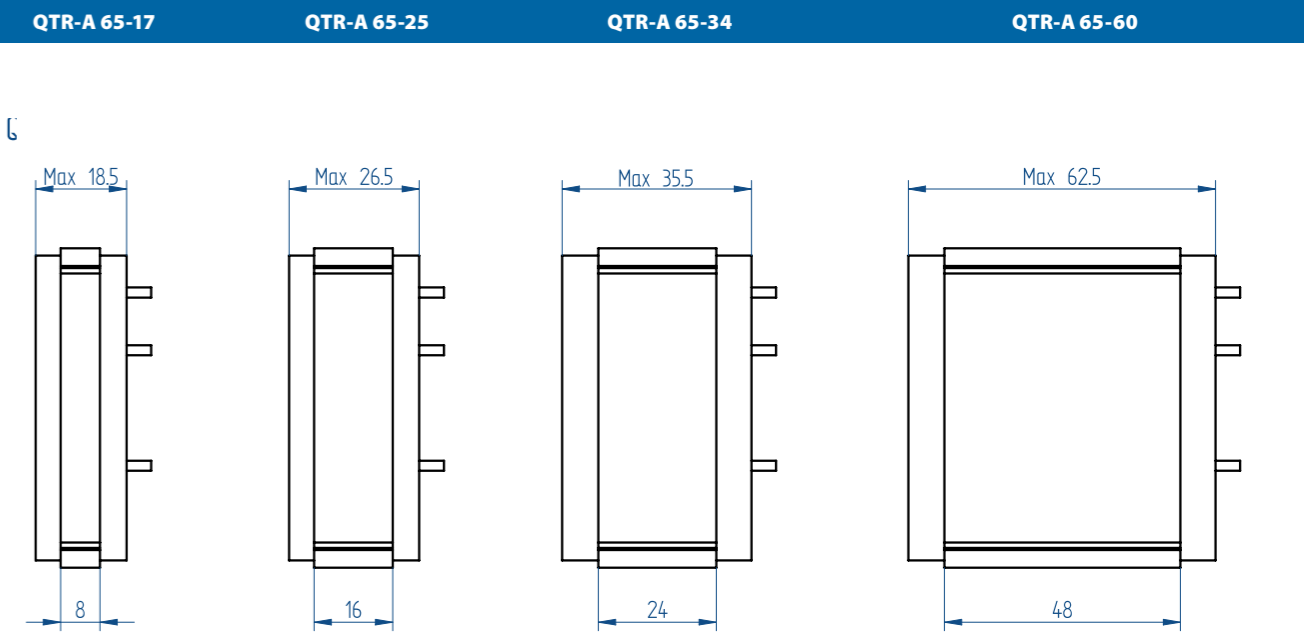
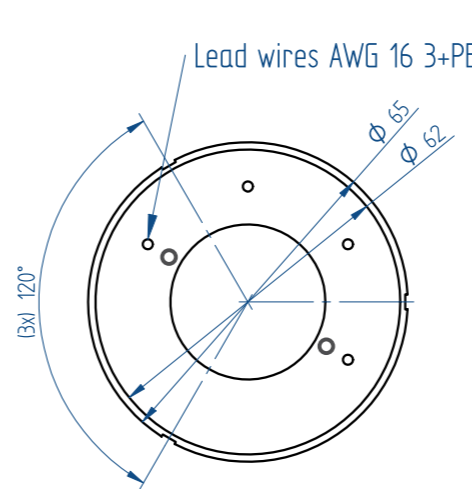

Rotor

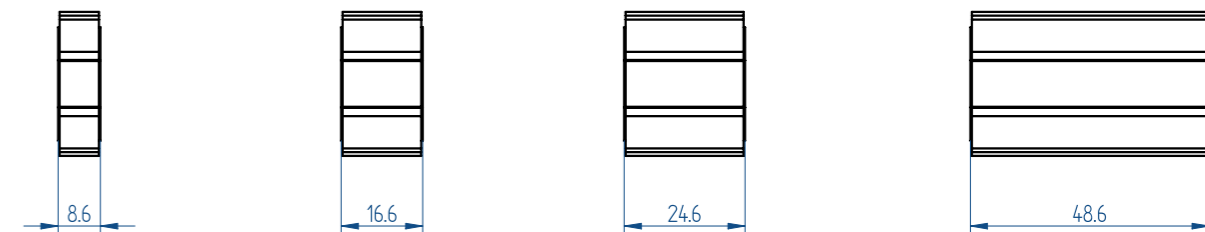
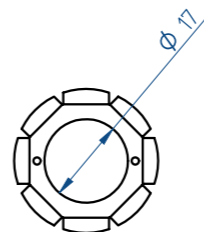

Mounting instructions and tolerances can be found in the torque installation manual. Manuals and 3D CAD files can be downloaded from our website.

\*All sizes are in mm

# Torque QTR 78 series



QTR-A 78 Stator and rotor shown with a height of 17 mm

Parameter	Remarks	Symbol	Unit	QTR-A 78-17	QTR-A 78-25	QTR-A 78-34	QTR-A 78-60
Winding type				N	Y	Y	Y
Motor type max. voltage ph-ph	3-phase synchronous		$V_{ac,rms} (V_{dc})$	420 (600)			
Ultimate torque @ 20°C/s increase	magnet @ 25°C	$T_u$	Nm	1.22	2.93	4.54	10.85
Peak torque @ 6°C/s increase	magnet @ 25°C	$T_p$	Nm	0.84	1.90	2.88	7.57
Continuous torque	coil @ 100°C	$T_c$	Nm	0.57	1.38	2.19	4.41
Maximum speed <sup>(3)</sup> @ 48 Volt	@ $T_c$ @ 48 V <sub>dc</sub>	$n_{max}$	rpm	2657	2360	1463	324
Maximum speed @ max. voltage	@ $T_c$	$n_{max}$	rpm	23000	23000	23000	8147
Motor torque constant	up to $I_c$	$K_t$	Nm/A <sub>rms</sub>	0.117	0.131	0.198	0.530
Motor constant	coils @ 25°C	$K_m$	(Nm) <sup>2</sup> /W	0.0053	0.0166	0.0304	0.0842
Ultimate current	magnet @ 25°C	$I_u$	A <sub>rms</sub>	13.84	27.98	27.98	24.99
Peak current	magnet @ 25°C	$I_p$	A <sub>rms</sub>	7.58	15.32	15.32	15.05
Maximum continuous current <sup>(1)</sup>	coils @ 100°C	$I_c$	A <sub>rms</sub>	4.89	10.56	11.08	8.33
Back EMF phase-phase <sub>peak</sub>		$K_e$	V/krpm	10.0	11.2	16.9	45.3
Back EMF phase-phase <sub>RMS</sub>		$K_e$	V/krpm	7.1	7.9	12.0	32.0
Coil resistance per phase	coils @ 25°C ex. cable	R	Ω	0.857	0.342	0.430	1.111
Coil induction per phase	$I < 0.6 I_p$	L	mH	1.35	0.76	1.04	3.4
Electrical time constant	coils @ 25°C	$\tau_e$	ms	1.6	2.2	2.4	3.1
Poles		$N_{mgn}$	nr	12	12	12	12
Continuous power loss	coils @ 100°C	$P_c$	W	80	150	207	302
Thermal resistance <sup>(2)</sup>	coils to mount. sfc.	$R_{th}$	°C/W	0.99	0.53	0.39	0.26
Thermal time constant	up to 63% max. coiltemp.	$\tau_{th}$	s	20	16	16	41
Temperature cut-off / sensor				No temperature sensor			
Stator OD		OD <sub>s</sub>	mm	78			
Rotor ID		ID <sub>R</sub>	mm	29			
Motor height		H <sub>motor</sub>	mm	18	26	35	62
Lamination stack height		H <sub>arm</sub>	mm	8	16	24	48
Rotor inertia		J <sub>R</sub>	kg*m <sup>2</sup>	1.3E-05	2.5E-05	3.8E-05	7.6E-05
Stator mass	excluding cables	M <sub>s</sub>	g	208	353	501	1003
Rotor mass		M <sub>R</sub>	g	42	84	126	243
Total mass	excluding cables	M <sub>T</sub>	g	250	437	627	1246
Cable mass	all cables	m	g	36			
Cable type (power)	length 0.5 m	d	mm (AWG)	2.06 (16)			

1. These values are only applicable when the mounting surface is at 20°C and the motor is driven at maximum continuous current. If these values differ in your application, please check our simulation tool or manual.
2. R<sub>th</sub> based on radial mounting of stator lamination stack.
3. MAXIMUM allowable speed for QTR-A 78 series motors is 23.000 rpm. If you plan a high speed application, please contact Tecnotion.

All specifications ±10%

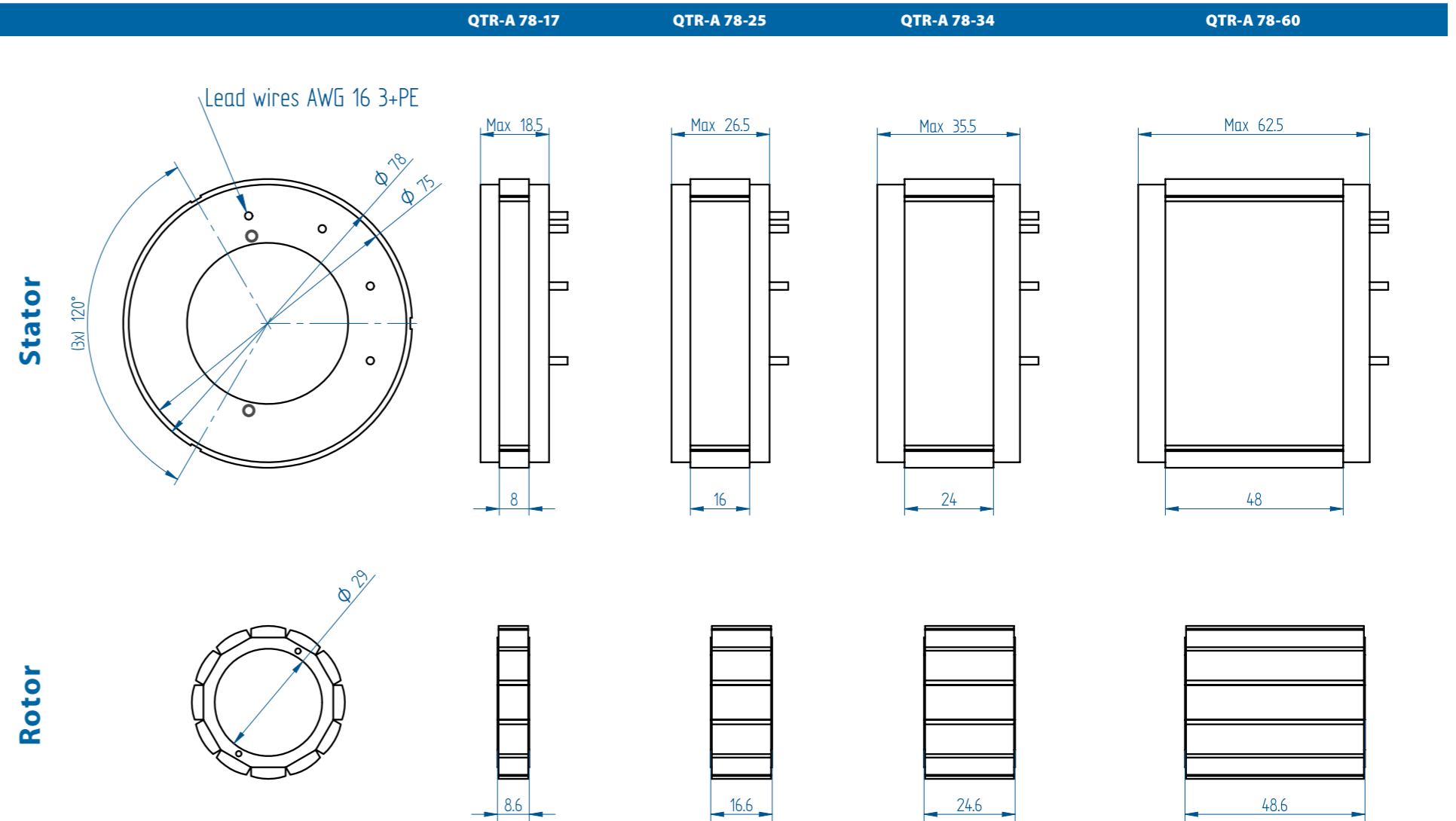

Mounting instructions and tolerances can be found in the torque installation manual. Manuals and 3D CAD files can be downloaded from our website.

\*All sizes are in mm



# Torque QTR 105 series



QTR-A-105 Stator and rotor shown with a height of 17 mm

1. These values are only applicable when the mounting surface is at 20°C and the motor is driven at maximum continuous current. If these values differ in your application, please check our simulation tool or manual.
2. R<sub>th</sub> based on radial mounting of stator lamination stack.
3. MAXIMUM allowable speed for QTR-A 105 series motors is 16.500 rpm. If you plan a high speed application, please contact Tecnotion.

Parameter	Remarks	Symbol	Unit	QTR-A-105-17			QTR-A-105-25			QTR-A-105-34			QTR-A-105-60		
				N	Y	Z	N	Y	Z	N	Y	Z	N		
<b>Performance</b>	Winding type			N Y Z N Y Z N Y Z N											
	Motor type max. voltage ph-ph	3-phase synchronous	V <sub>ac rms</sub> (V <sub>dc</sub> )	230 (325)											420 (600)
	Ultimate torque @ 20°C/s increase	magnet @ 25°C	T <sub>u</sub>	Nm	2.9	3.3	3.3	6.1	7.5	6.9	10.6	11.3	10.4	28.4	
	Peak torque @ 6°C/s increase	magnet @ 25°C	T <sub>p</sub>	Nm	1.9	2.2	2.2	3.9	4.4	4.4	6.7	6.6	6.6	18.1	
	Continuous torque	coil @ 100°C	T <sub>c</sub>	Nm	1.4	1.4	1.4	3.2	3.3	3.3	5.4	5.2	5.2	12.0	
	Maximum speed <sup>(1)</sup> @ 48 Volt	@ T <sub>c</sub>	n <sub>max</sub>	rpm	784	1761	3300	240	783	1623	0	444	1028	0	
	Maximum speed @ max. voltage	@ T <sub>c</sub>	n <sub>max</sub>	rpm	6890	12286	16500	3625	6534	11399	1928	4439	7833	1455	
	Motor torque constant	up to I <sub>c</sub>	K <sub>t</sub>	Nm/A <sub>rms</sub>	0.30	0.17	0.10	0.60	0.33	0.19	1.07	0.50	0.29	2.86	
	Motor constant	coils @ 25°C	K <sub>m</sub>	(Nm) <sup>2</sup> /W	0.021	0.022	0.022	0.061	0.065	0.065	0.127	0.115	0.120	0.40	
<b>Electrical</b>	Ultimate current	magnet @ 25°C	I <sub>u</sub>	A <sub>rms</sub>	13.8	28.2	48.8	13.8	28.2	48.8	13.3	28.2	48.8	13.5	
	Peak current	magnet @ 25°C	I <sub>p</sub>	A <sub>rms</sub>	7.6	15.4	26.7	7.6	15.4	26.7	7.3	15.4	26.7	7.37	
	Maximum continuous current <sup>(1)</sup>	coils @ 100°C	I <sub>c</sub>	A <sub>rms</sub>	4.6	8.5	14.7	5.3	9.8	17.0	5.1	10.3	17.9	4.2	
	Back EMF phase-phase <sub>peak</sub>		K <sub>e</sub>	V/krpm	25	14	8	51	28	16	92	43	25	244	
	Back EMF phase-phase <sub>RMS</sub>		K <sub>e</sub>	V/krpm	18	10	6	36	20	12	65	30	17	173	
	Coil resistance per phase	coils @ 25°C ex. cable	R	Ω	1.38	0.43	0.14	1.93	0.57	0.19	3.02	0.74	0.24	6.84	
	Coil induction per phase	I < 0.6 I <sub>p</sub>	L	mH	2.58	0.83	0.28	4.05	1.29	0.43	7.93	1.75	0.59	25.3	
	Electrical time constant	coils @ 25°C	τ <sub>e</sub>	ms	1.9	2.0	1.9	2.1	2.3	2.2	2.6	2.4	2.4	3.7	
	Poles		N <sub>mgn</sub>	nr	20	20	20	20	20	20	20	20	20	20	
	Continuous power loss	coils @ 100°C	P <sub>c</sub>	W	115	115	115	214	214	214	300	300	300	469	
<b>Thermal</b>	Thermal resistance <sup>(2)</sup>	coils to mount. sfc.	R <sub>th</sub>	°C/W	0.65	0.65	0.65	0.35	0.35	0.35	0.25	0.25	0.25	0.16	
	Thermal time constant	up to 63% max. coiltemp.	τ <sub>th</sub>	s	21	25	25	16	18	18	17	17	17	25	
Temperature cut-off / sensor				PTC 1kΩ / KTY83-122											
<b>Mechanical</b>	Stator OD	OD <sub>s</sub>	mm	105											
	Rotor ID	ID <sub>R</sub>	mm	56											
	Motor height	H <sub>motor</sub>	mm	17			25			34			60		
	Lamination stack height	H <sub>arm</sub>	mm	8			16			24			48		
	Rotor inertia	J <sub>R</sub>	kg*m <sup>2</sup>	8.0E-05			1.5E-04			2.2E-04			4.3E-04		
	Stator mass	excluding cables	M <sub>s</sub>	g	299			472			746			1476	
	Rotor mass		M <sub>R</sub>	g	79			146			218			433	
	Total mass	excluding cables	M <sub>T</sub>	g	378			618			964			1909	
	Cable mass	all cables	m	g	63	90	90	63	90	90	63	90	90	95	
	Cable type (power)	length 0.5 m	d	mm (AWG)	6.5 (20)	6.7 (14)	6.7 (14)	6.5 (20)	6.7 (14)	6.7 (14)	6.5 (20)	6.7 (14)	6.7 (14)	9.6 (18)	
Cable type (sensor)	length 0.5 m	d	mm (AWG)	4.3 (26)											

All specifications ±10%

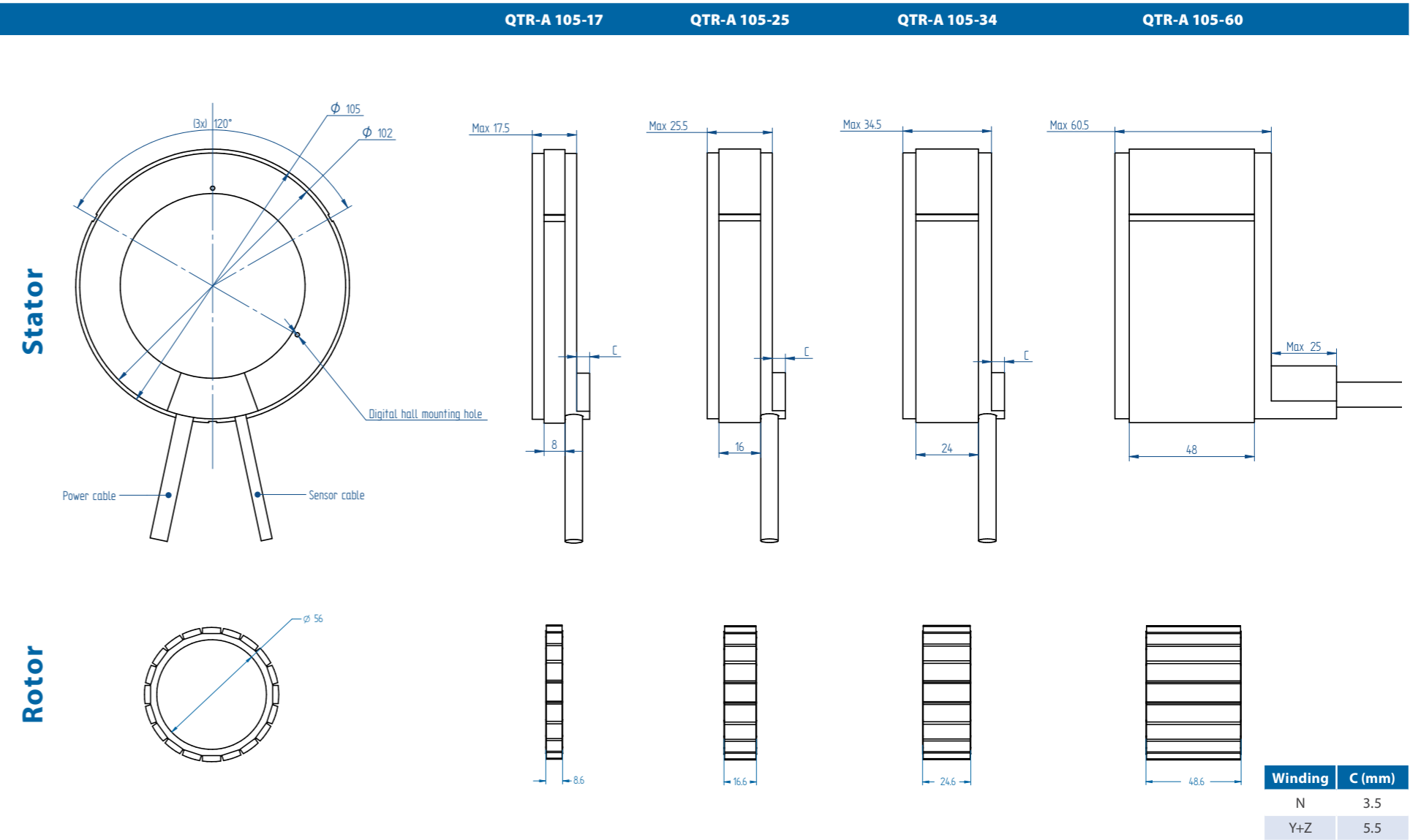

Mounting instructions and tolerances can be found in the torque installation manual. Manuals and 3D CAD files can be downloaded from our website.

\*All sizes are in mm

# Torque QTR 133 series



QTR-A-133 Stator and rotor shown with a height of 17 mm

Parameter	Remarks	Symbol	Unit	QTR-A-133-17			QTR-A-133-25			QTR-A-133-34		QTR-A-133-60
				N	Y	Z	N	Y	Z	N	Z	N
<b>Performance</b>												
Winding type				N Y Z N Y Z N Z N								
Motor type max. voltage ph-ph	3-phase synchronous		$V_{acrms} (V_{dc})$	230 (325)								
Ultimate torque @ 20°C/s increase	magnet @ 25°C	$T_u$	Nm	5.6	6.4	6.4	11.9	13.5	13.5	20.6	20.3	55.5
Peak torque @ 6°C/s increase	magnet @ 25°C	$T_p$	Nm	3.8	4.3	4.3	7.5	8.6	8.6	13.1	12.9	35.3
Continuous torque	coil @ 100°C	$T_c$	Nm	2.6	2.6	2.6	5.9	6.0	6.0	10.0	9.5	21.9
Maximum speed <sup>(3)</sup> @ 48 Volt	@ $T_c$	$n_{max}$	rpm	317	839	1641	33	345	788	0	478	0
Maximum speed @ max. voltage	@ $T_c$	$n_{max}$	rpm	3514	6340	10807	1825	3389	5930	946	4040	724
Motor torque constant	up to $I_c$	$K_t$	Nm/A <sub>rms</sub>	0.58	0.33	0.19	1.16	0.65	0.38	2.09	0.56	5.57
Motor constant	coils @ 25°C	$K_m$	(Nm) <sup>2</sup> /W	0.058	0.061	0.061	0.167	0.177	0.180	0.344	0.310	1.08
<b>Electrical</b>												
Ultimate current	magnet @ 25°C	$I_u$	A <sub>rms</sub>	13.8	28.2	48.8	13.8	28.2	48.8	13.3	48.8	13.5
Peak current	magnet @ 25°C	$I_p$	A <sub>rms</sub>	7.56	15.40	26.70	7.56	15.40	26.70	7.31	26.70	7.37
Maximum continuous current <sup>(1)</sup>	coils @ 100°C	$I_c$	A <sub>rms</sub>	4.43	8.10	14.00	5.05	9.30	16.10	4.77	16.90	3.93
Back EMF phase-phase <sub>peak</sub>		$K_e$	V/krpm	50	28	16	99	56	32	179	48	476
Back EMF phase-phase <sub>RMS</sub>		$K_e$	V/krpm	35	20	11	70	39	23	126	34	337
Coil resistance per phase	coils @ 25°C ex. cable	R	Ω	1.93	0.58	0.20	2.70	0.80	0.27	4.23	0.34	9.58
Coil induction per phase	$L < 0.6 I_p$	L	mH	3.74	1.20	0.40	5.87	1.87	0.62	11.50	0.85	36.6
Electrical time constant	coils @ 25°C	$\tau_e$	ms	1.9	2.1	2.0	2.2	2.4	2.3	2.7	2.5	3.8
Poles		$N_{mgn}$	nr	28	28	28	28	28	28	28	28	28
<b>Thermal</b>												
Continuous power loss	coils @ 100°C	$P_c$	W	147	147	147	268	268	268	375	375	577
Thermal resistance <sup>(2)</sup>	coils to mount. sfc.	$R_{th}$	°C/W	0.51	0.51	0.51	0.28	0.28	0.28	0.20	0.20	0.13
Thermal time constant	up to 63% max. coiltemp.	$\tau_{th}$	s	23	27	27	18	21	21	19	19	29
Temperature cut-off / sensor				PTC 1kΩ / KTY83-122								
<b>Mechanical</b>												
Stator OD		OD <sub>s</sub>	mm	133								
Rotor ID		ID <sub>R</sub>	mm	84								
Motor height		H <sub>motor</sub>	mm	17			25			34		60
Lamination stack height		H <sub>arm</sub>	mm	8			16			24		48
Rotor inertia		$J_R$	kg*m <sup>2</sup>	2.1E-04			4.2E-04			6.2E-04		1.2E-03
Stator mass	excluding cables	$M_s$	g	414			717			1037		2090
Rotor mass		$M_R$	g	106			208			309		613
Total mass	excluding cables	$M_T$	g	520			925			1346		2703
Cable mass	all cables	m	g	63	90	90	63	90	90	63	90	95
Cable type (power)	length 0.5 m	d	mm (AWG)	6.5 (20)	6.7 (14)	6.7 (14)	6.5 (20)	6.7 (14)	6.7 (14)	6.5 (20)	6.7 (14)	9.6 (18)
Cable type (sensor)	length 0.5 m	d	mm (AWG)	4.3 (26)								

- These values are only applicable when the mounting surface is at 20°C and the motor is driven at maximum continuous current. If these values differ in your application, please check our simulation tool or manual.
- R<sub>th</sub> based on radial mounting of stator lamination stack.
- MAXIMUM allowable speed for QTR-A 133 series motors is 14,000 rpm. If you plan a high speed application, please contact Tecnotion.

All specifications ±10%

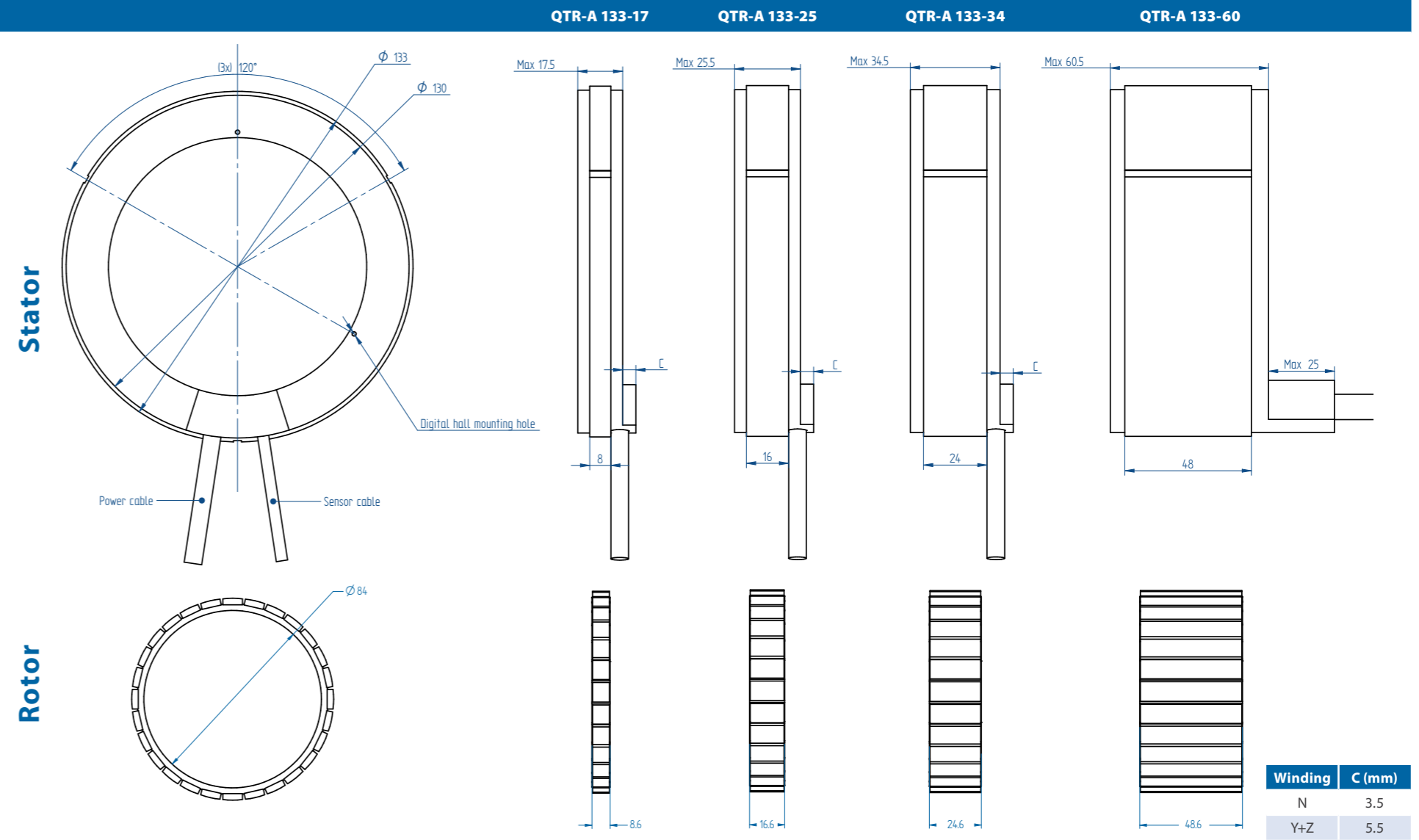

Mounting instructions and tolerances can be found in the torque installation manual. Manuals and 3D CAD files can be downloaded from our website.

\*All sizes are in mm

# Torque QTR 160 series



QTR-A-160 Stator and rotor shown with a height of 17 mm

Parameter	Remarks	Symbol	Unit	QTR-A-160-17			QTR-A-160-25			QTR-A-160-34		QTR-A-160-60	
				N	Y	Z	N	Y	Z	N	Z	N	
<b>Performance</b>													
Winding type				N								N	
Motor type max. voltage ph-ph	3-phase synchronous		$V_{ac rms} (V_{dc})$	230 (325)								420 (600)	
Ultimate torque @ 20°C/s increase	magnet @ 25°C	$T_u$	Nm	9.3	10.6	10.6	19.6	22.4	22.4	34.1	33.6	91.6	
Peak torque @ 6°C/s increase	magnet @ 25°C	$T_p$	Nm	6.2	7.1	7.1	12.5	14.2	14.2	21.7	21.4	58.3	
Continuous torque	coil @ 100°C	$T_c$	Nm	4.1	4.2	4.2	9.4	9.7	9.7	15.7	15.0	36.3	
Maximum speed <sup>(3)</sup> @ 48 Volt	@ $T_c$	$n_{max}$	rpm	142	467	965	0	165	441	0	259	0	
Maximum speed @ max. voltage	@ $T_c$	$n_{max}$	rpm	2145	3871	6663	1084	2039	3604	555	2464	411	
Motor torque constant	up to $I_c$	$K_t$	Nm/A <sub>rms</sub>	0.96	0.54	0.31	1.92	1.07	0.62	3.45	0.93	9.20	
Motor constant	coils @ 25°C	$K_m$	(Nm) <sup>2</sup> /W	0.12	0.13	0.13	0.35	0.38	0.38	0.73	0.67	2.29	
<b>Electrical</b>													
Ultimate current	magnet @ 25°C	$I_u$	A <sub>rms</sub>	13.8	28.2	48.8	13.8	28.2	48.8	13.3	48.8	13.5	
Peak current	magnet @ 25°C	$I_p$	A <sub>rms</sub>	7.6	15.4	26.7	7.6	15.4	26.7	7.3	26.7	7.4	
Maximum continuous current <sup>(1)</sup>	coils @ 100°C	$I_c$	A <sub>rms</sub>	4.3	7.8	13.4	4.9	9.0	15.7	4.6	16.2	3.9	
Back EMF phase-phase <sub>peak</sub>		$K_e$	V/krpm	82	46	26	164	92	53	295	79	787	
Back EMF phase-phase <sub>RMS</sub>		$K_e$	V/krpm	58	32	19	116	65	37	209	56	556	
Coil resistance per phase	coils @ 25°C ex. cable	R	Ω	2.47	0.75	0.25	3.47	1.03	0.35	5.45	0.44	12.30	
Coil induction per phase	$L < 0.6 I_p$	L	mH	4.89	1.57	0.52	7.68	2.45	0.82	15.0	1.11	47.9	
Electrical time constant	coils @ 25°C	$\tau_e$	ms	2.0	2.1	2.1	2.2	2.4	2.4	2.8	2.5	3.9	
Poles		$N_{mgn}$	nr	36	36	36	36	36	36	36	36	36	
<b>Thermal</b>													
Continuous power loss	coils @ 100°C	$P_c$	W	174	174	174	326	326	326	441	441	750	
Thermal resistance <sup>(2)</sup>	coils to mount. sfc.	$R_{th}$	°C/W	0.43	0.43	0.43	0.23	0.23	0.23	0.17	0.17	0.10	
Thermal time constant	up to 63% max. coiltemp	$\tau_{th}$	s	25	29	29	19	22	22	21	21	29	
Temperature cut-off / sensor				PTC 1kΩ / KTY83-122									
<b>Mechanical</b>													
Stator OD		$OD_s$	mm	160									
Rotor ID		$ID_R$	mm	111									
Motor height		$H_{motor}$	mm	17			25			34		60	
Lamination stack height		$H_{arm}$	mm	8			16			24		48	
Rotor inertia		$J_R$	kg*m <sup>2</sup>	4.7E-04			9.2E-04			1.4E-03		2.6E-03	
Stator mass	excluding cables	$M_s$	g	527			875			1212		2555	
Rotor mass		$M_R$	g	138			269			401		754	
Total mass	excluding cables	$M_T$	g	665			1144			1613		3309	
Cable mass	all cables	m	g	63	90	90	63	90	90	63	90	95	
Cable type (power)	length 0.5 m	d	mm (AWG)	6.5 (20)	6.7 (14)	6.7 (14)	6.5 (20)	6.7 (14)	6.7 (14)	6.5 (20)	6.7 (14)	9.6 (18)	
Cable type (sensor)	length 0.5 m	d	mm (AWG)	4.3 (26)									

- These values are only applicable when the mounting surface is at 20°C and the motor is driven at maximum continuous current. If these values differ in your application, please check our simulation tool or manual.
- $R_{th}$  based on radial mounting of stator lamination stack.
- MAXIMUM allowable speed for QTR-A 160 series motors is 12,000 rpm. If you plan a high speed application, please contact Tecnotion.

All specifications ±10%

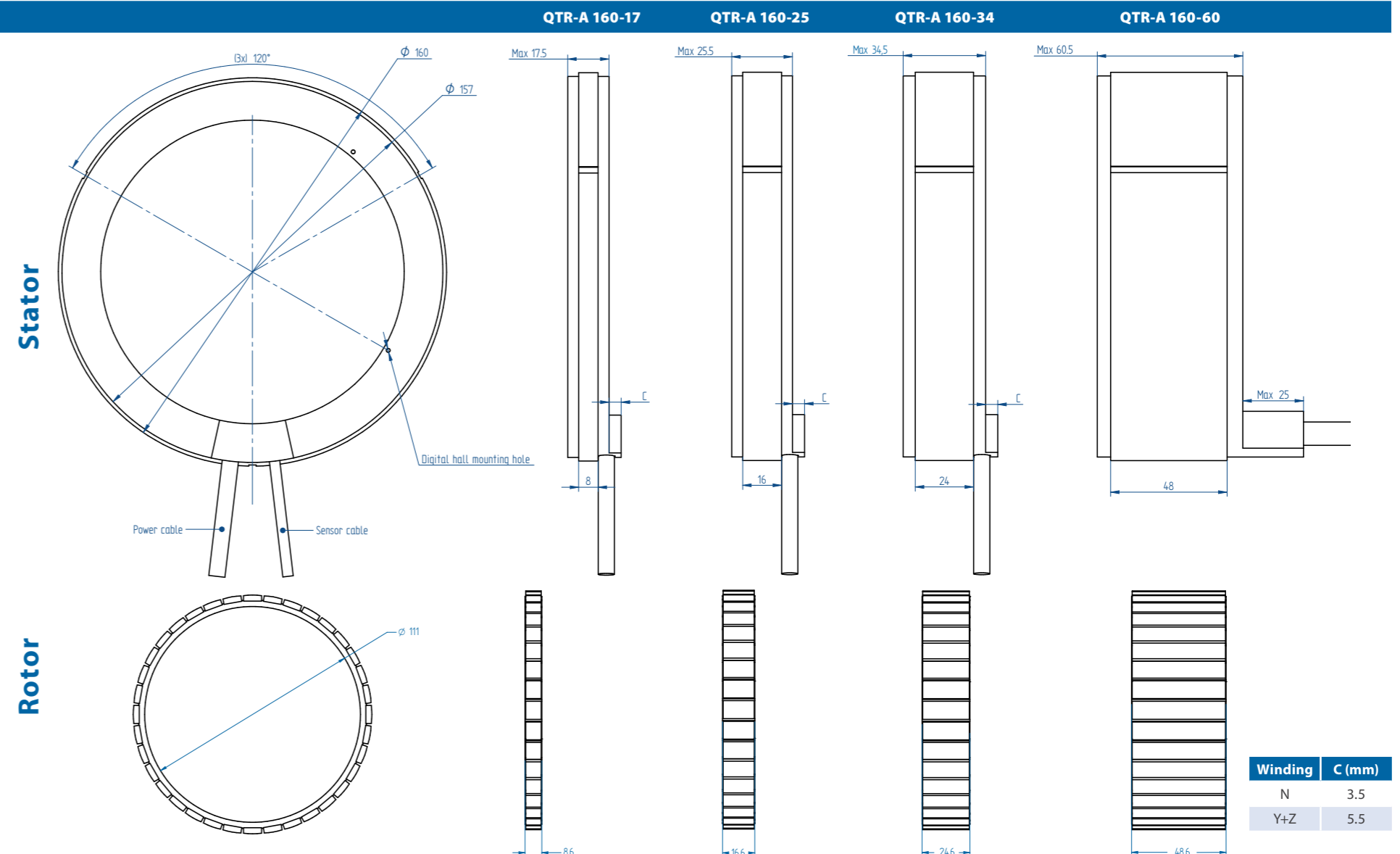

Mounting instructions and tolerances can be found in the torque installation manual. Manuals and 3D CAD files can be downloaded from our website.

\*All sizes are in mm



QTL 210 series,  
with a height of 65 mm

# Torque QTL 210 series

Parameter	Remarks	Symbol	Unit	QTL-A 210-65	QTL-A 210-85	QTL-A 210-105
<b>Performance</b>				N	N	N
Winding type						
Motor type max. voltage ph-ph	3-phase synchronous		$V_{acrms} (V_{dc})$		480 (680)	
Ultimate torque @ 20°C/s increase	magnet @ 25°C	$T_u$	Nm	173	259	346
Peak torque @ 6°C/s increase	magnet @ 25°C	$T_p$	Nm	140	211	281
Continuous torque	coil @ 100°C	$T_c$	Nm	65	103	142
Stall torque	coil @ 100°C	$T_s$	Nm	46	73	100
Maximum speed <sup>(1)</sup>	@ $T_c$ @ 680 V <sub>dc</sub>	$n_{max}$	rpm	716	457	326
Motor torque constant	up to $I_c$	$K_t$	Nm/A <sub>rms</sub>	8.7	13.1	17.5
Motor constant	coils @ 25°C	$K_m$	(Nm) <sup>2</sup> /W	8.0	13.5	19.2
<b>Electrical</b>						
Ultimate current	magnet @ 25°C	$I_u$	A <sub>rms</sub>	22.0	22.0	22.0
Peak current	magnet @ 25 °C	$I_p$	A <sub>rms</sub>	16.9	16.9	16.9
Maximum continuous current <sup>(2)</sup>	coils @ 100°C	$I_c$	A <sub>rms</sub>	7.45	7.88	8.11
Stall current <sup>(2)</sup>	coils @ 100°C	$I_s$	A <sub>rms</sub>	5.27	5.57	5.74
Back EMF phase-phase <sub>peak</sub>		$K_e$	V/krpm	747	1121	1494
Back EMF phase-phase <sub>RMS</sub>		$K_e$	V/krpm	528	793	1057
Coil resistance per phase	coils @ 25°C ex. cable	R	Ω	3.18	4.25	5.31
Coil induction per phase	$I < 0.6 I_p$	L	mH	16.0	22.3	28.7
Electrical time constant		$\tau_e$	ms	5.0	5.3	5.4
Poles		$N_{mgn}$	nr	26	26	26
<b>Thermal</b>						
Continuous power loss	coils @ 100°C	$P_c$	W	690	1028	1363
Thermal resistance <sup>(3)</sup>	coils to mount. sfc.	$R_{th}$	°C/W	0.116	0.078	0.059
Thermal time constant		$\tau_{th}$	s	53	47	45
Temperature cut-off / sensor				PTC 1kΩ (3x) / PT1000 (3x)		
<b>Mechanical</b>						
Stator OD		OD <sub>S</sub>	mm	210		
Rotor ID		ID <sub>R</sub>	mm	140		
Motor height		H <sub>motor</sub>	mm	65	85	105
Lamination stack height		H <sub>arm</sub>	mm	40	60	80
Rotor inertia		J <sub>R</sub>	kg*m <sup>2</sup>	0.009	0.014	0.019
Stator mass	excluding cables	M <sub>S</sub>	kg	4.2	5.9	7.5
Rotor mass		M <sub>R</sub>	kg	1.6	2.4	3.2
Total mass	excluding cables	M <sub>T</sub>	kg	5.8	8.3	10.7
Cable mass	all cables	m	g	500		
Cable type (power)	length 2 m	d	mm (AWG)	10.6 (13)		
Cable type (sensor)	length 2 m	d	mm (AWG)	6.4 (25)		

- Actual values depend on bus voltage. Please check the T/n diagram in our manual or online simulation tool.
- These values are only applicable when the mounting surface is at 20°C and the motor is driven at maximum continuous current. If these values differ in your application, please check our simulation tool or manual.
- R<sub>th</sub> based on radial mounting of stator lamination stack.

All specifications ±10%

Stator

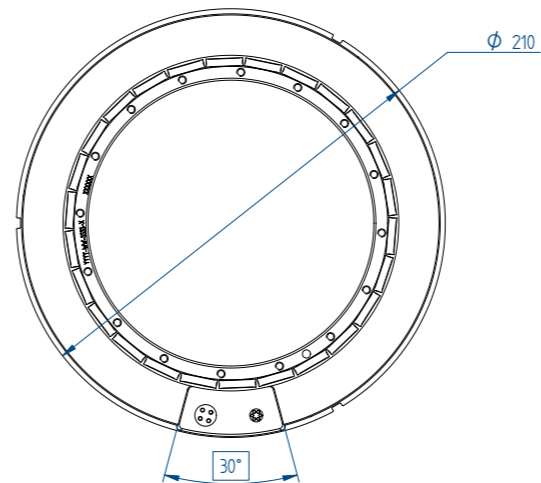

Rotor

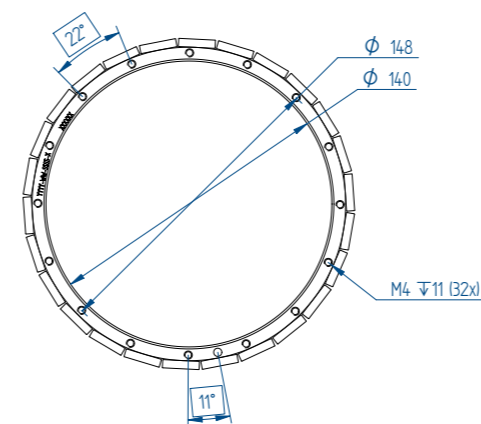

QTL-A 210-65

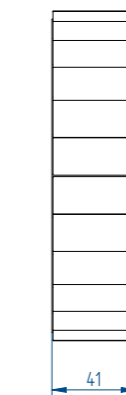
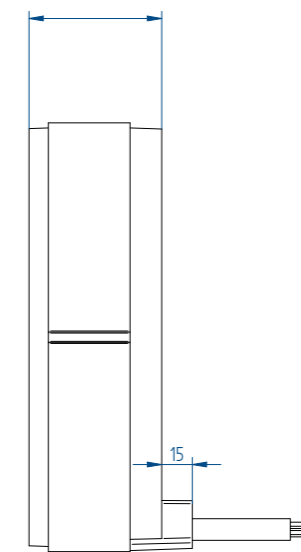

QTL-A 210-85

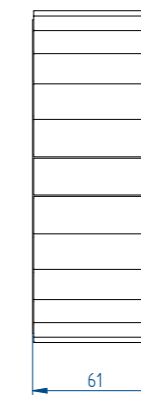
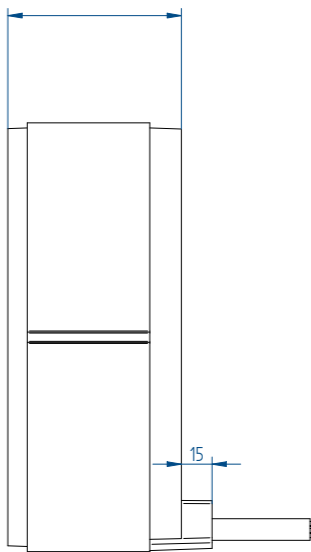

QTL-A 210-105

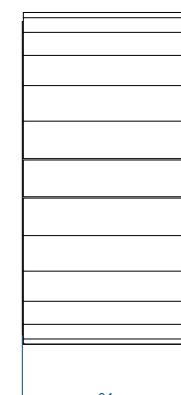
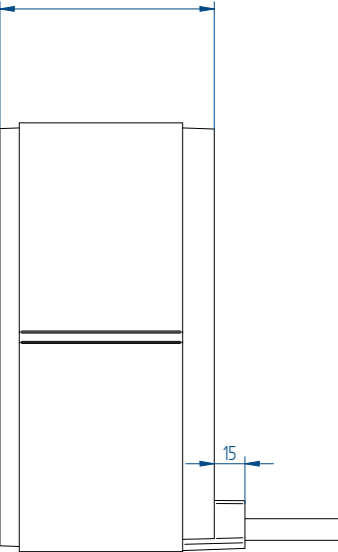

Mounting instructions and tolerances can be found in the torque installation manual. Manuals and 3D CAD files can be downloaded from our website.

\*All sizes are in mm



QTL 230 series,  
with a height of 85 mm

## Torque QTL 230 series with cooling ring

Parameter	Remarks	Symbol	Unit	QTL-A 230-65	QTL-A 230-85	QTL-A 230-105
<b>Winding type</b>				N	N	N
<b>Motor type max. voltage ph-ph</b>	3-phase synchronous		$V_{ac,rms} (V_{dc})$		480 (680)	
<b>Ultimate torque @ 20°C/s increase</b>	magnet @ 25°C	$T_u$	Nm	173	259	346
<b>Peak torque @ 6°C/s increase</b>	magnet @ 25°C	$T_p$	Nm	140	211	281
<b>Continuous torque</b>	coil @ 100°C	$T_c$	Nm	67	107	147
<b>Stall torque</b>	coil @ 100°C	$T_s$	Nm	48	76	104
<b>Maximum speed<sup>(1)</sup></b>	@ $T_c$ @ 680 V <sub>dc</sub>	$n_{max}$	rpm	709	451	321
<b>Motor torque constant</b>	up to $I_c$	$K_t$	Nm/A <sub>rms</sub>	8.7	13.1	17.5
<b>Motor constant</b>	coils @ 25°C	$K_m$	(Nm) <sup>2</sup> /W	8.0	13.5	19.2
<b>Ultimate current</b>	magnet @ 25°C	$I_u$	A <sub>rms</sub>	22.0	22.0	22.0
<b>Peak current</b>	magnet @ 25 °C	$I_p$	A <sub>rms</sub>	16.9	16.9	16.9
<b>Maximum continuous current<sup>(2)</sup></b>	coils @ 100°C	$I_c$	A <sub>rms</sub>	7.69	8.16	8.42
<b>Stall current<sup>(2)</sup></b>	coils @ 100°C	$I_s$	A <sub>rms</sub>	5.44	5.77	5.95
<b>Back EMF phase-phase<sub>peak</sub></b>		$K_e$	V/krpm	747	1121	1494
<b>Back EMF phase-phase<sub>RMS</sub></b>		$K_e$	V/krpm	528	793	1057
<b>Coil resistance per phase</b>	coils @ 25°C ex. cable	$R$	Ω	3.18	4.25	5.31
<b>Coil induction per phase</b>	$l < 0.6 I_p$	$L$	mH	16.0	22.3	28.7
<b>Electrical time constant</b>		$\tau_e$	ms	5.0	5.3	5.4
<b>Poles</b>		$N_{mgn}$	nr	26	26	26
<b>Continuous power loss</b>	coils @ 100°C	$P_c$	W	735	1102	1469
<b>Thermal resistance<sup>(3)</sup></b>	coils to mount. sfc.	$R_{th}$	°C/W	0.109	0.073	0.054
<b>Thermal time constant</b>	up to 63% max. coiltemp	$\tau_{th}$	s	49	44	41
<b>Water cooling flow</b>	for $\Delta T=3K$	$\Phi_w$	l/min	3.5	5.3	7.0
<b>Water cooling pressure drop</b>	order of magnitude	$\Delta P_w$	bar	0.7	1.0	1.5
<b>Temperature cut-off / sensor</b>				PTC 1kΩ (3x) / PT1000 (3x)		
<b>Stator OD</b>		$OD_s$	mm	230		
<b>Rotor ID</b>		$ID_R$	mm	140		
<b>Motor height</b>		$H_{motor}$	mm	65	85	105
<b>Lamination stack height</b>		$H_{arm}$	mm	40	60	80
<b>Rotor inertia</b>		$J_R$	kg*m <sup>2</sup>	0.009	0.014	0.019
<b>Stator mass</b>	excluding cables	$M_s$	kg	5.2	7.2	9.0
<b>Rotor mass</b>		$M_R$	kg	1.6	2.4	3.2
<b>Total mass</b>	excluding cables	$M_T$	kg	6.8	9.6	12.2
<b>Cable mass</b>	all cables	$m$	g	500		
<b>Cable type (power)</b>	length 2 m	$d$	mm (AWG)	10.6 (13)		
<b>Cable type (sensor)</b>	length 2 m	$d$	mm (AWG)	6.4 (25)		

- Actual values depend on bus voltage. Please check the T/n diagram in our manual or online simulation tool.
- These values are only applicable when the mounting surface is at 20°C and the motor is driven at maximum continuous current. If these values differ in your application, please check our simulation tool or manual.
- R<sub>th</sub> based on given water flow and pressure.

All specifications ±10%

Stator

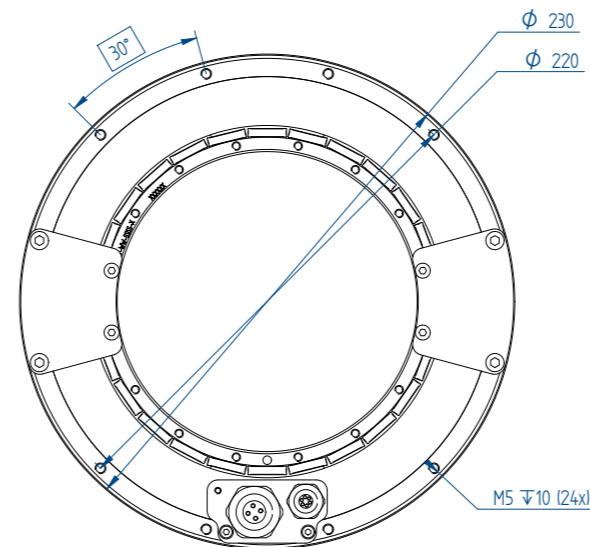

Rotor

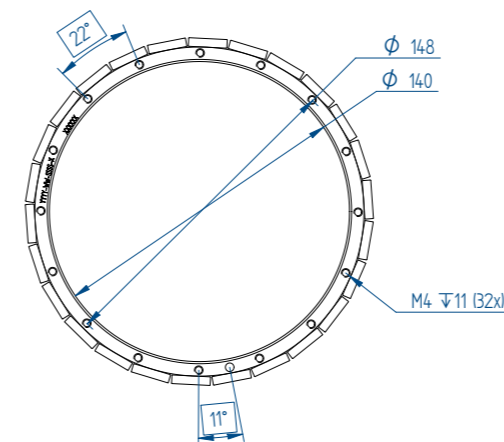

QTL-A 230-65

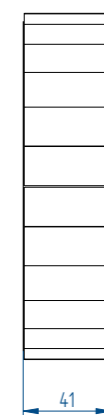
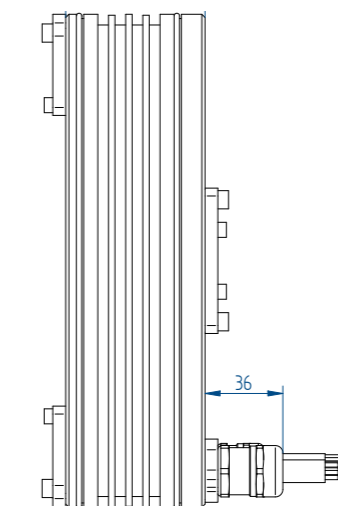

QTL-A 230-85

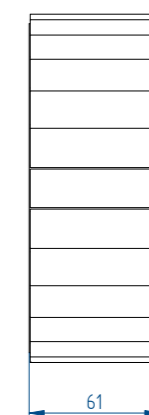
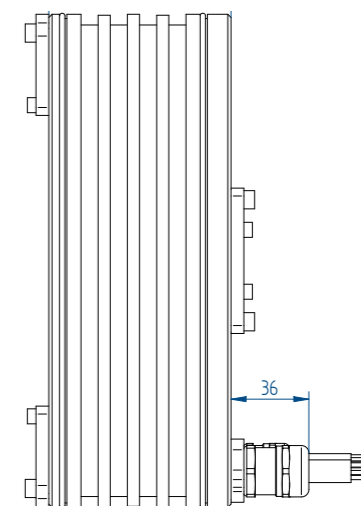

QTL-A 230-105

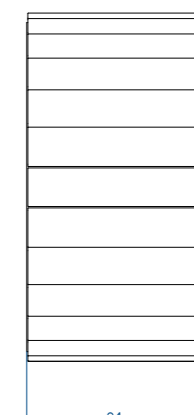
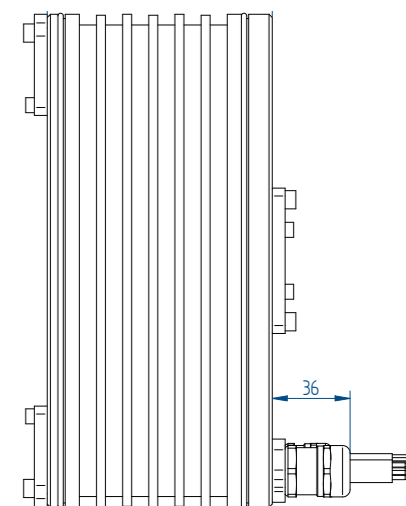

Mounting instructions and tolerances can be found in the torque installation manual. Manuals and 3D CAD files can be downloaded from our website.

\*All sizes are in mm

# Torque QTL 290 series



QTL 290 series,  
with a height of 65 mm

Parameter	Remarks	Symbol	Unit	QTL-A 290-65	QTL-A 290-85	QTL-A 290-105
<b>Performance</b>				N	N	N
Winding type						
Motor type max. voltage ph-ph	3-phase synchronous		$V_{ac,rms} (V_{dc})$		480 (680)	
Ultimate torque @ 20°C/s increase	magnet @ 25°C	$T_u$	Nm	389	583	778
Peak torque @ 6°C/s increase	magnet @ 25°C	$T_p$	Nm	316	474	632
Continuous torque	coil @ 100°C	$T_c$	Nm	140	222	305
Stall torque	coil @ 100°C	$T_s$	Nm	99	157	215
Maximum speed <sup>(1)</sup>	@ $T_c$ @ 680 V <sub>dc</sub>	$n_{max}$	rpm	306	189	130
Motor torque constant	up to $I_c$	$K_t$	Nm/A <sub>rms</sub>	19.7	29.5	39.3
Motor constant	coils @ 25°C	$K_m$	(Nm) <sup>2</sup> /W	27.0	45.5	64.7
<b>Electrical</b>						
Ultimate current	magnet @ 25°C	$I_u$	A <sub>rms</sub>	22.0	22.0	22.0
Peak current	magnet @ 25°C	$I_p$	A <sub>rms</sub>	16.9	16.9	16.9
Maximum continuous current <sup>(2)</sup>	coils @ 100°C	$I_c$	A <sub>rms</sub>	7.14	7.54	7.75
Stall current <sup>(2)</sup>	coils @ 100°C	$I_s$	A <sub>rms</sub>	5.05	5.33	5.48
Back EMF phase-phase <sub>peak</sub>		$K_e$	V/krpm	1681	2521	3362
Back EMF phase-phase <sub>RMS</sub>		$K_e$	V/krpm	1189	1783	2377
Coil resistance per phase	coils @ 25°C ex. cable	R	Ω	4.77	6.37	7.96
Coil induction per phase	$I < 0.6 I_p$	L	mH	23.9	34.7	45.5
Electrical time constant		$\tau_e$	ms	5.0	5.5	5.7
Poles		$N_{mgn}$	nr	38	38	38
<b>Thermal</b>						
Continuous power loss	coils @ 100°C	$P_c$	W	948	1410	1864
Thermal resistance <sup>(3)</sup>	coils to mount. sfc.	$R_{th}$	°C/W	0.084	0.057	0.043
Thermal time constant	up to 63% max. coiltemp	$\tau_{th}$	s	57	52	49
Temperature cut-off / sensor				PTC 1kΩ (3x) / PT1000 (3x)		
<b>Mechanical</b>						
Stator OD		OD <sub>s</sub>	mm	290		
Rotor ID		ID <sub>r</sub>	mm	220		
Motor height		H <sub>motor</sub>	mm	65	85	105
Lamination stack height		H <sub>arm</sub>	mm	40	60	80
Rotor inertia		J <sub>R</sub>	kg*m <sup>2</sup>	0.031	0.046	0.061
Stator mass	excluding cables	M <sub>S</sub>	kg	6.0	8.3	10.8
Rotor mass		M <sub>R</sub>	kg	2.3	3.5	4.7
Total mass	excluding cables	M <sub>T</sub>	kg	8.3	11.8	15.5
Cable mass	all cables	m	g	500		
Cable type (power)	length 2 m	d	mm (AWG)	10.6 (13)		
Cable type (sensor)	length 2 m	d	mm (AWG)	6.4 (25)		

1. Actual values depend on bus voltage.

Please check the T/n diagram in our manual or online simulation tool.

2. These values are only applicable when the mounting surface is at 20°C and the motor is driven at maximum continuous current.

If these values differ in your application, please check our simulation tool or manual.

3. R<sub>th</sub> based on radial mounting of stator lamination stack.

All specifications ±10%

Stator

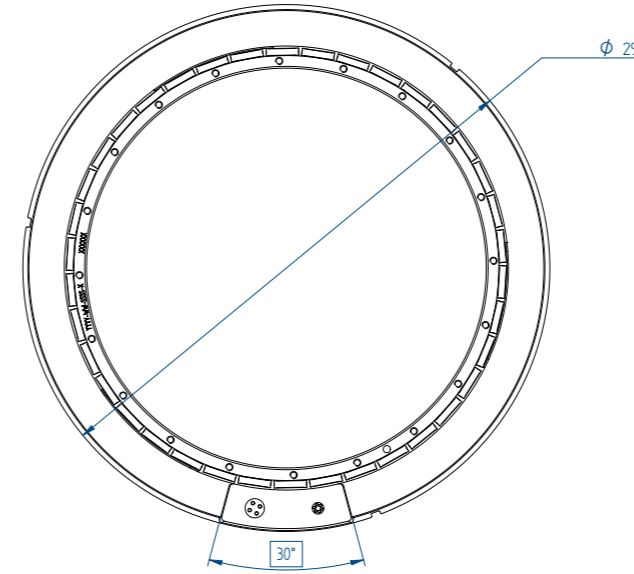

Rotor

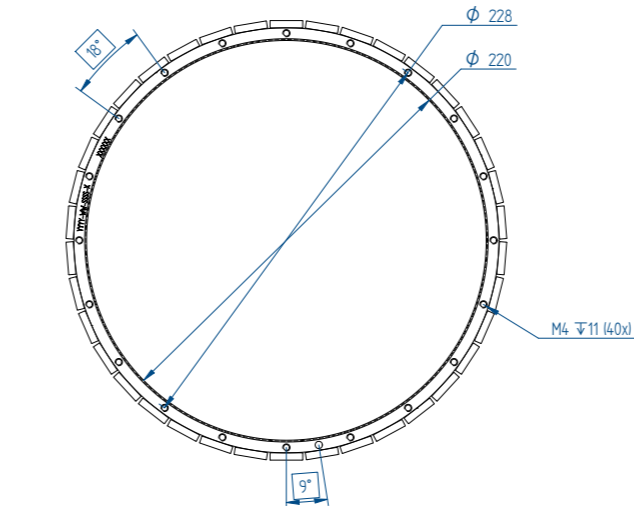

QTL-A 290-65

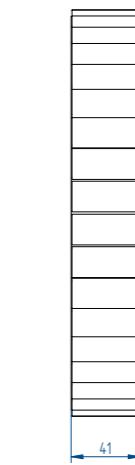
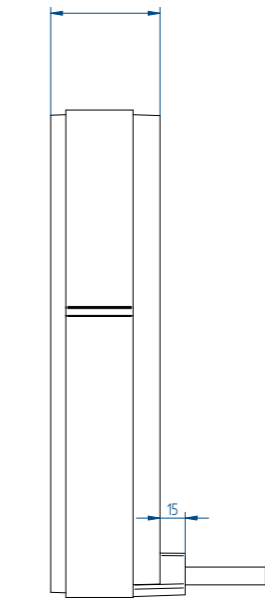

QTL-A 290-85

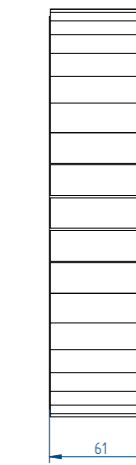
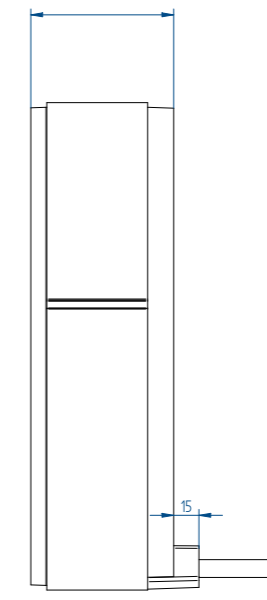

QTL-A 290-105

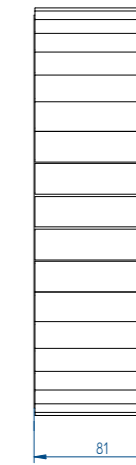
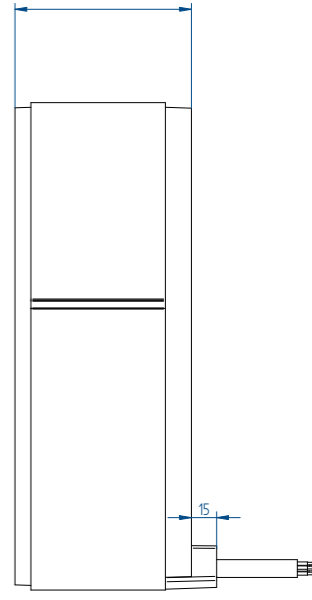

Mounting instructions and tolerances can be found in the torque installation manual. Manuals and 3D CAD files can be downloaded from our website.

\* All sizes are in mm



QTL 310 series,  
with a height of 85 mm

## Torque QTL 310 series with cooling ring

Parameter	Remarks	Symbol	Unit	QTL-A 310-65	QTL-A 310-85	QTL-A 310-105
<b>Performance</b>				N	N	N
Winding type	3-phase synchronous					
Motor type max. voltage ph-ph			$V_{ac,rms} (V_{dc})$		480 (680)	
Ultimate torque @ 20°C/s increase	magnet @ 25°C	$T_u$	Nm	389	583	778
Peak torque @ 6°C/s increase	magnet @ 25°C	$T_p$	Nm	316	474	632
Continuous torque	coil @ 100°C	$T_c$	Nm	151	241	331
Stall torque	coil @ 100°C	$T_s$	Nm	107	170	234
Maximum speed <sup>(1)</sup>	@ $T_c$ @ 680 V <sub>dc</sub>	$n_{max}$	rpm	298	182	124
Motor torque constant	up to $I_c$	$K_t$	Nm/A <sub>rms</sub>	19.7	29.5	39.3
Motor constant	coils @ 25°C	$K_m$	(Nm) <sup>2</sup> /W	27.0	45.5	64.7
<b>Electrical</b>						
Ultimate current	magnet @ 25°C	$I_u$	A <sub>rms</sub>	22.0	22.0	22.0
Peak current	magnet @ 25°C	$I_p$	A <sub>rms</sub>	16.9	16.9	16.9
Maximum continuous current <sup>(2)</sup>	coils @ 100°C	$I_c$	A <sub>rms</sub>	7.70	8.16	8.42
Stall current <sup>(2)</sup>	coils @ 100°C	$I_s$	A <sub>rms</sub>	5.44	5.77	5.96
Back EMF phase-phase <sub>peak</sub>		$K_e$	V/krpm	1681	2521	3362
Back EMF phase-phase <sub>RMS</sub>		$K_e$	V/krpm	1189	1783	2377
Coil resistance per phase	coils @ 25°C ex. cable	R	Ω	4.77	6.37	7.96
Coil induction per phase	$I < 0.6 I_p$	L	mH	23.9	34.7	45.5
Electrical time constant		$\tau_e$	ms	5.0	5.5	5.7
Poles		$N_{mgn}$	nr	38	38	38
<b>Thermal</b>						
Continuous power loss	coils @ 100°C	$P_c$	W	1102	1653	2204
Thermal resistance <sup>(3)</sup>	coils to mount. sfc.	$R_{th}$	°C/W	0.073	0.048	0.036
Thermal time constant	up to 63% max. coiltemp	$\tau_{th}$	s	49	44	41
Water cooling flow	for $\Delta T=3K$	$\Phi_w$	l/min	5.3	7.9	10.5
Water cooling pressure drop	order of magnitude	$\Delta P_w$	bar	1.0	1.4	2.0
Temperature cut-off / sensor				PTC 1kΩ (3x) / PT1000 (3x)		
<b>Mechanical</b>						
Stator OD		OD <sub>s</sub>	mm		310	
Rotor ID		ID <sub>R</sub>	mm		220	
Motor height		H <sub>motor</sub>	mm	65	85	105
Lamination stack height		H <sub>arm</sub>	mm	40	60	80
Rotor inertia		J <sub>R</sub>	kg·m <sup>2</sup>	0.031	0.046	0.061
Stator mass	excluding cables	M <sub>s</sub>	kg	7.4	10.1	12.9
Rotor mass		M <sub>R</sub>	kg	2.3	3.5	4.7
Total mass	excluding cables	M <sub>T</sub>	kg	9.7	13.6	17.6
Cable mass	all cables	m	g		500	
Cable type (power)	length 2 m	d	mm (AWG)		10.6 (13)	
Cable type (sensor)	length 2 m	d	mm (AWG)		6.4 (25)	

- Actual values depend on bus voltage. Please check the T/n diagram in our manual or online simulation tool.
- These values are only applicable when the mounting surface is at 20°C and the motor is driven at maximum continuous current. If these values differ in your application, please check our simulation tool or manual.
- R<sub>th</sub> based on given water flow and pressure.

All specifications ±10%

Stator

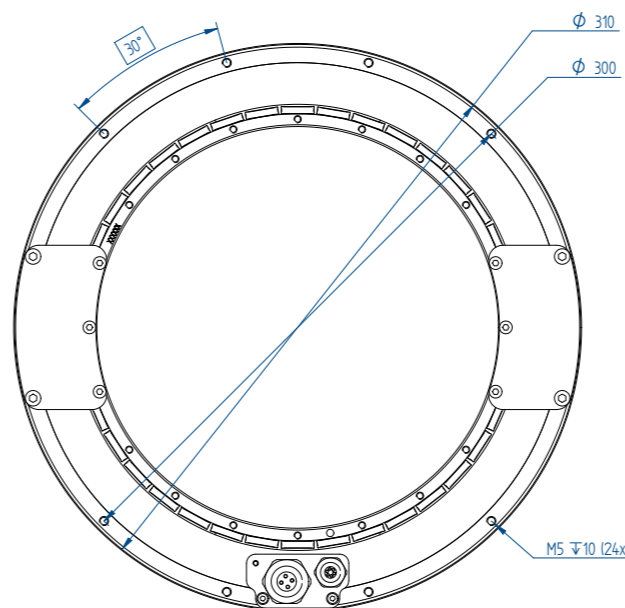

Rotor

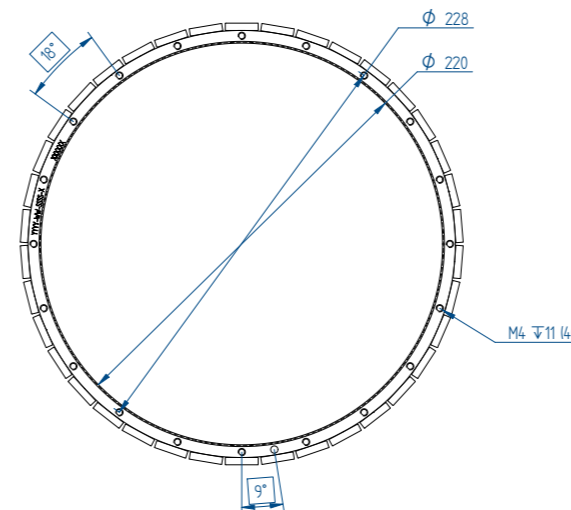

QTL-A 310-65

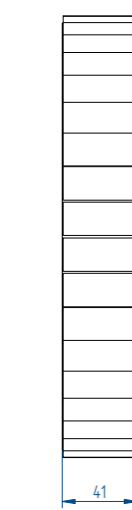
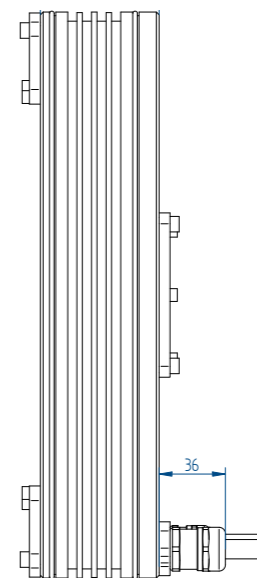

QTL-A 310-85

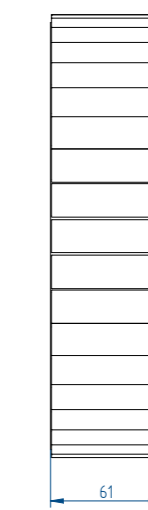
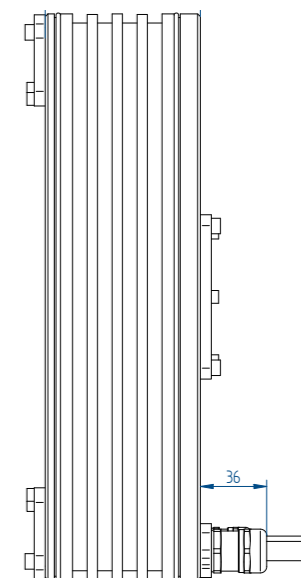

QTL-A 310-105

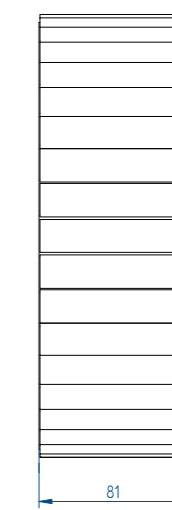
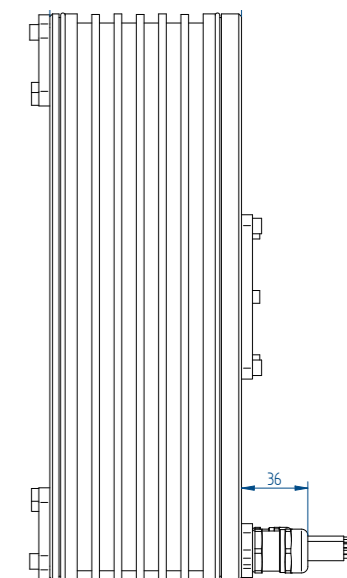

Mounting instructions and tolerances can be found in the torque installation manual. Manuals and 3D CAD files can be downloaded from our website.

\*All sizes are in mm



QTL 385 series,  
with a height of 85 mm

## Torque QTL 385 series with cooling ring

Parameter	Remarks	Symbol	Unit	QTL-A 385-85	QTL-A 385-105
<b>Performance</b>				I	I
Winding type					
Motortype max. voltage ph-ph	3-phase synchronous		$V_{ac\ rms} (V_{dc})$	480 (680)	
Ultimate torque @ 20°C/s increase	magnet @ 25°C	$T_u$	Nm	1026	1368
Peak torque @ 6°C/s increase	magnet @ 25°C	$T_p$	Nm	833	1111
Continuous torque	coil @ 100°C	$T_c$	Nm	407	560
Stall torque	coil @ 100°C	$T_s$	Nm	288	396
Maximum speed <sup>(1)</sup>	@ $T_c$ @ 680 Vdc	$n_{max}$	rpm	231	164
Motor torque constant	up to $I_c$	$K_t$	Nm/A <sub>rms</sub>	25.9	34.6
Motor constant	coils @ 25°C	$K_m$	(Nm) <sup>2</sup> /W	105.4	149.9
<b>Electrical</b>					
Ultimate current	magnet @ 25°C	$I_u$	A <sub>rms</sub>	44.0	44.0
Peak current	magnet @ 25°C	$I_p$	A <sub>rms</sub>	33.8	33.8
Maximum continuous current <sup>(2)</sup>	coils @ 100°C	$I_c$	A <sub>rms</sub>	15.7	16.2
Stall current <sup>(2)</sup>	coils @ 100°C	$I_s$	A <sub>rms</sub>	11.1	11.5
Back EMF phase-phase <sub>peak</sub>		$K_e$	V/krpm	2217	2956
Back EMF phase-phase <sub>RMS</sub>		$K_e$	V/krpm	1567	2090
Coil resistance per phase	coils @ 25°C ex. cable	R	Ω	2.13	2.66
Coil induction per phase	$l < 0.6 l_p$	L	mH	11.6	15.2
Electrical time constant		$\tau_e$	ms	5.4	5.7
Poles		$N_{mgn}$	nr	50	50
<b>Thermal</b>					
Continuous power loss	coils @ 100°C	$P_c$	W	2044	2724
Thermal resistance <sup>(3)</sup>	coils to mount. sfc.	$R_{th}$	°C/W	0.039	0.029
Thermal time constant		$\tau_{th}$	s	48	45
Water cooling flow	for $\Delta T=3K$	$\Phi_w$	l/min	9.8	13.0
Temperature cut-off / sensor				PTC 1kΩ (3x)/ PT1000 (3x)	
<b>Mechanical</b>					
Stator OD		$OD_s$	mm	385	
Rotor ID		$ID_R$	mm	280	
Motor height		$H_{motor}$	mm	85	105
Lamination stack height		$H_{arm}$	mm	60	80
Rotor inertia		$J_R$	kg*m <sup>2</sup>	0.146	0.195
Stator mass	excluding cables	$M_s$	kg	12.75	17
Rotor mass		$M_R$	kg	6.68	8.9
Total mass	excluding cables	$M_T$	kg	19.43	25.9
Cable mass	all cables	m	kg	0.5	
Cable type (power)	length 2 m	d	mm (AWG)	10.6 (13)	
Cable type (sensor)	length 2 m	d	mm (AWG)	8.9 (22)	

- Actual values depend on bus voltage. Please check the T/n diagram in our manual or online simulation tool.
- These values are only applicable when the mounting surface is at 20°C and the motor is driven at maximum continuous current. If these values differ in your application, please check our simulation tool or manual.
- $R_{th}$  based on given water flow and pressure.

All specifications ±10%

Stator

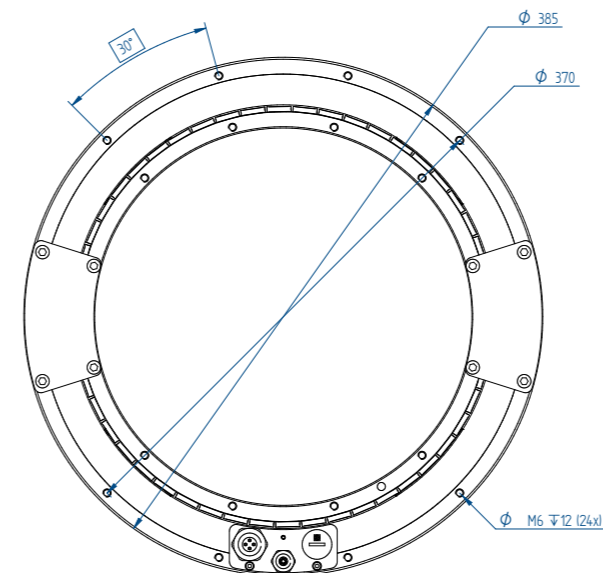

Rotor

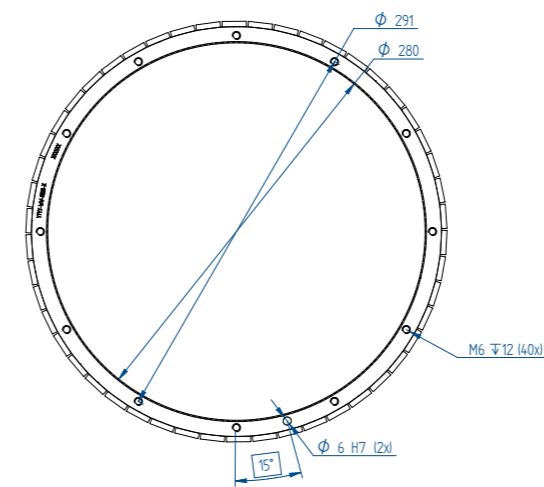

QTL-A 385-85

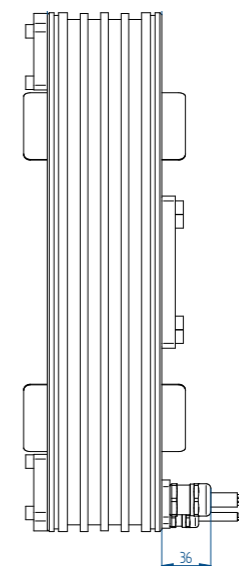

QTL-A 385-105

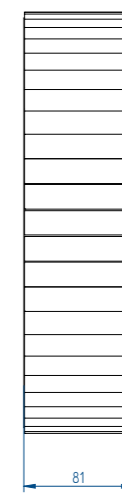
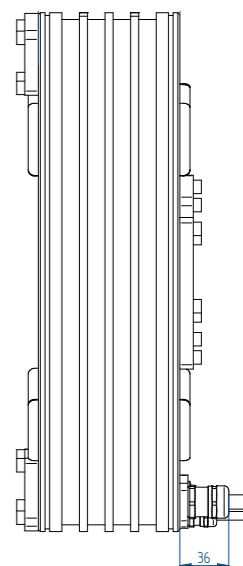

Mounting instructions and tolerances can be found in the torque installation manual. Manuals and 3D CAD files can be downloaded from our website.

\* All sizes are in mm





QTL 485 series,  
with a height of 105 mm

## Torque QTL 485 series with cooling ring

Parameter	Remarks	Symbol	Unit	QTL-A 485-85	QTL-A 485-105
<b>Performance</b>				I	I
Winding type					
Motor type max. voltage ph-ph	3-phase synchronous		$V_{ac,rms} (V_{dc})$	480 (680)	
Ultimate torque @ 20°C/s increase	magnet @ 25°C	$T_u$	Nm	1651	2202
Peak torque @ 6°C/s increase	magnet @ 25°C	$T_p$	Nm	1342	1789
Continuous torque	coil @ 100°C	$T_c$	Nm	659	907
Stall torque	coil @ 100°C	$T_s$	Nm	466	642
Maximum speed <sup>(1)</sup>	@ $T_c$ @ 680 Vdc	$n_{max}$	rpm	138	96
Motor torque constant	up to $I_c$	$K_t$	Nm/A <sub>rms</sub>	41.7	55.6
Motor constant	coils @ 25°C	$K_m$	(Nm) <sup>2</sup> /W	218.5	310.7
<b>Electrical</b>					
Ultimate current	magnet @ 25°C	$I_u$	A <sub>rms</sub>	44.0	44.0
Peak current	magnet @ 25°C	$I_p$	A <sub>rms</sub>	33.8	33.8
Maximum continuous current <sup>(2)</sup>	coils @ 100°C	$I_c$	A <sub>rms</sub>	15.8	16.3
Stall current <sup>(2)</sup>	coils @ 100°C	$I_s$	A <sub>rms</sub>	11.2	11.5
Back EMF phase-phase <sub>peak</sub>		$K_e$	V/krpm	3569	4758
Back EMF phase-phase <sub>RMS</sub>		$K_e$	V/krpm	2523	3364
Coil resistance per phase	coils @ 25°C ex. cable	R	Ω	2.66	3.32
Coil induction per phase	$I < 0.6 I_p$	L	mH	14.5	19.0
Electrical time constant		$\tau_e$	ms	5.4	5.7
Poles		$N_{mgn}$	nr	62	62
<b>Thermal</b>					
Continuous power loss	coils @ 100°C	$P_c$	W	2584	3444
Thermal resistance <sup>(3)</sup>	coils to mount. sfc.	$R_{th}$	°C/W	0.031	0.023
Thermal time constant		$\tau_{th}$	s	47	44
Water cooling flow	for $\Delta T=3K$	$\Phi_w$	l/min	12.4	16.5
Temperature cut-off / sensor				PTC 1kΩ (3x) / PT1000 (3x)	
<b>Mechanical</b>					
Stator OD		$OD_s$	mm	485	
Rotor ID		$ID_R$	mm	366	
Motor height		$H_{motor}$	mm	85	105
Lamination stack height		$H_{arm}$	mm	60	80
Rotor inertia		$J_R$	kg*m <sup>2</sup>	0.357	0.476
Stator mass	excluding cables	$M_s$	kg	18.75	25
Rotor mass		$M_R$	kg	9.68	12.9
Total mass	excluding cables	$M_T$	kg	28.43	37.9
Cable mass	all cables	m	kg	0.5	
Cable type (power)	length 2 m	d	mm (AWG)	10.6 (13)	
Cable type (sensor)	length 2 m	d	mm (AWG)	8.9 (22)	

- Actual values depend on bus voltage. Please check the T/n diagram in our manual or online simulation tool.
- These values are only applicable when the mounting surface is at 20°C and the motor is driven at maximum continuous current. If these values differ in your application, please check our simulation tool or manual.
- $R_{th}$  based on given water flow and pressure.

All specifications ±10%

Stator

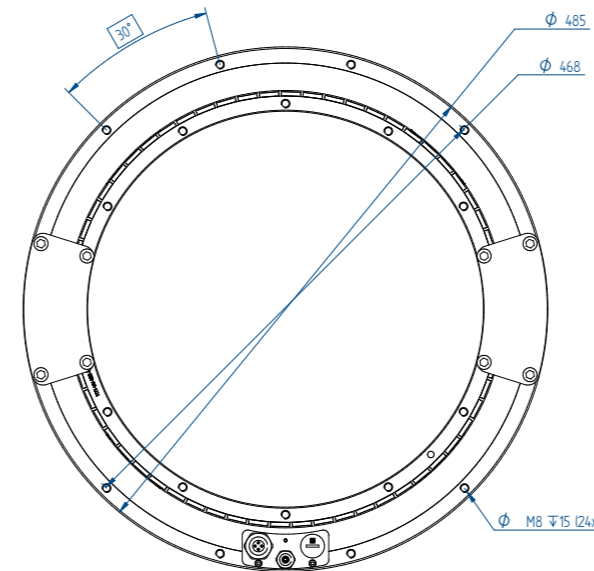

Rotor

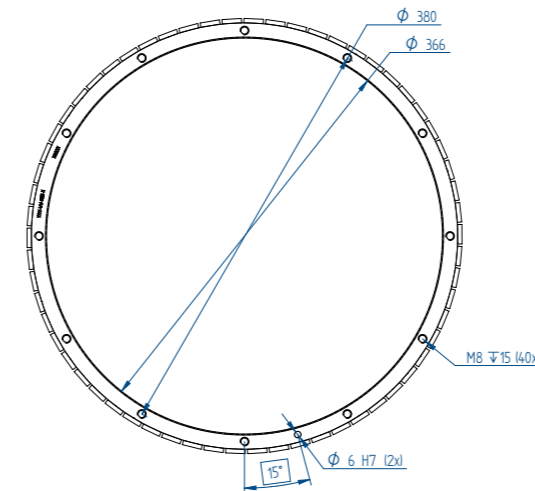

QTL-A-485-85

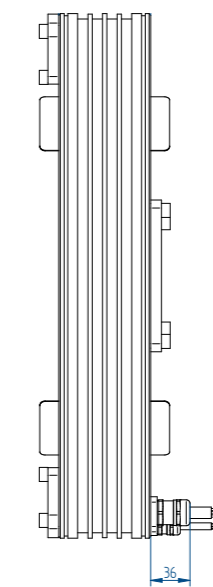

QTL-A 485-105

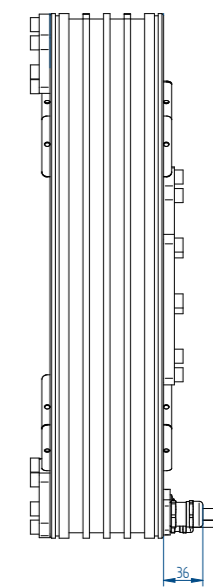

Mounting instructions and tolerances can be found in the torque installation manual. Manuals and 3D CAD files can be downloaded from our website.

\*All sizes are in mm

# Additions

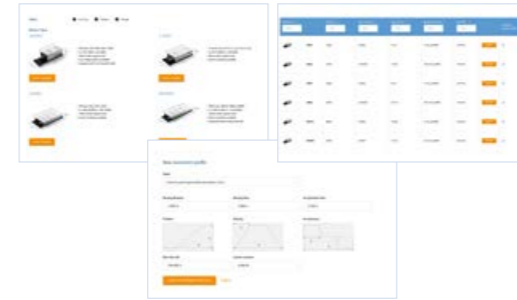

To use our motor simulation tool, download 3D & CAD files, installation manuals, product specifications and more, visit our website at: [www.tecnotion.com](http://www.tecnotion.com)

## Linear motors

### Iron core & ironless motor series

Tecnotion's linear motor series rely on 30 years of linear motor development experience. All motors excel in their force density ratings. They offer continuous force in a range of 10 Newton to 3000 Newton in a surprisingly small package.

Tecnotion can provide linear solutions for most applications which require a strong iron core linear motor or a highly dynamic ironless type linear motor.

## Vacuum series

### Outgassing down to 10<sup>-8</sup> mbar

Many years of experience is used in designing and building vacuum coils and magnets. Tecnotion can supply any vacuum linear motor that can match even the strictest vacuum requirements, for instance in the semiconductor industry.

Our vacuum rated ironless linear motors are specifically designed coil units and magnet yokes for use in high vacuum, down to 10<sup>-8</sup> mbar.

## Simulation tool

### Analyze your application

Save precious time by using our FREE online motor simulation tool. Our specialized software helps you find the best motor for the application and generate reports within seconds, without having to make time consuming calculations by hand.

The tool will provide you with diagrams for position, velocity, acceleration, jerk, torque, power, voltage, current, temperature and torque vs. velocity. Find the simulation tool at [www.tecnotion.com/simtool](http://www.tecnotion.com/simtool)

## Custom motors

### Motor solutions

Besides the standard catalogue items we offer custom linear motor solutions. Some examples: custom windings, cable confection and vacuum motors for transport and positioning in vacuum.

Besides this Tecnotion offers moving magnet motors and linear solutions, completely designed toward your needs. For more information please contact Tecnotion.

# Article numbers

Series	Article	Article code	Series	Article	Article code
QTR	TORQUE KIT QTR-A-65-17 N	10 8062	QTR	TORQUE KIT QTR-A-160-17-Z	10 9402
QTR	TORQUE KIT QTR-A-65-25 N	10 8393	QTR	TORQUE KIT QTR-A-160-25-N	4022 368 6161
QTR	TORQUE KIT QTR-A-65-34 Y	10 8394	QTR	TORQUE KIT QTR-A-160-25-Y	10 9397
QTR	TORQUE KIT QTR-A-65-60 Y	10 8395	QTR	TORQUE KIT QTR-A-160-25-Z	10 9403
QTR	TORQUE KIT QTR-A-78-17 N	10 8397	QTR	TORQUE KIT QTR-A-160-34-N	4022 368 6162
QTR	TORQUE KIT QTR-A-78-25 Y	10 8399	QTR	TORQUE KIT QTR-A-160-34-Z	10 8160
QTR	TORQUE KIT QTR-A-78-34 Y	10 8400	QTR	TORQUE KIT QTR-A-160-60-N	4022 368 6163
QTR	TORQUE KIT QTR-A-78-60 Y	10 8401	QTR	DIGITAL HALL MODULE QTR 65	10 8781
QTR	TORQUE KIT QTR-A-105-17-N	4022 368 6120	QTR	DIGITAL HALL MODULE QTR 78	10 8782
QTR	TORQUE KIT QTR-A-105-17-Y	10 8848	QTR	DIGITAL HALL MODULE QTR 105	10 8233
QTR	TORQUE KIT QTR-A-105-17-Z	10 8158	QTR	DIGITAL HALL MODULE QTR 133	10 8234
QTR	TORQUE KIT QTR-A-105-25-N	4022 368 6121	QTR	DIGITAL HALL MODULE QTR 160	10 8235
QTR	TORQUE KIT QTR-A-105-25-Y	10 9393	QTL	TORQUE KIT QTL-A-210-65-N	11 1171
QTR	TORQUE KIT QTR-A-105-25-Z	10 9398	QTL	TORQUE KIT QTL-A-210-85-N	11 1173
QTR	TORQUE KIT QTR-A-105-34-N	4022 368 6122	QTL	TORQUE KIT QTL-A-210-105-N	11 1175
QTR	TORQUE KIT QTR-A-105-34-Y	10 9394	QTL	TORQUE KIT QTL-A-230-65-N	11 1127
QTR	TORQUE KIT QTR-A-105-34-Z	10 9399	QTL	TORQUE KIT QTL-A-230-85-N	11 1145
QTR	TORQUE KIT QTR-A-105-60-N	4022 368 6123	QTL	TORQUE KIT QTL-A-230-105-N	11 1153
QTR	TORQUE KIT QTR-A-133-17-N	4022 368 6140	QTL	TORQUE KIT QTL-A-290-65-N	11 1177
QTR	TORQUE KIT QTR-A-133-17-Y	10 9395	QTL	TORQUE KIT QTL-A-290-85-N	11 1180
QTR	TORQUE KIT QTR-A-133-17-Z	10 9400	QTL	TORQUE KIT QTL-A-290-105-N	11 1182
QTR	TORQUE KIT QTR-A-133-25-N	4022 368 6141	QTL	TORQUE KIT QTL-A-310-65-N	11 1078
QTR	TORQUE KIT QTR-A-133-25-Y	109396	QTL	TORQUE KIT QTL-A-310-85-N	11 1061
QTR	TORQUE KIT QTR-A-133-25-Z	10 8159	QTL	TORQUE KIT QTL-A-310-105-N	11 1100
QTR	TORQUE KIT QTR-A-133-34-N	4022 368 6142	QTL	TORQUE KIT QTL-A-385-85-I	11 1733
QTR	TORQUE KIT QTR-A-133-34-Z	10 9401	QTL	TORQUE KIT QTL-A-385-105-I	11 1732
QTR	TORQUE KIT QTR-A-133-60-N	4022 368 6143	QTL	TORQUE KIT QTL-A-485-85-I	11 1712
QTR	TORQUE KIT QTR-A-160-17-N	4022 368 6160	QTL	TORQUE KIT QTL-A-485-105-I	11 1711
QTR	TORQUE KIT QTR-A-160-17-Y	4022 368 5589			

**Tecnotion Headquarters**

Twentepoort West 15  
7609 RD Almelo  
The Netherlands

Tel. +31 (0)546 536 300  
Fax +31 (0)546 536 380  
sales@tecnotion.com

**Tecnotion N-W Europe**

High Tech Systems Park  
Building N  
Haaksbergerstraat 67  
7554 PA Hengelo  
P.O. Box 23, 7600 AA Almelo  
The Netherlands  
Tel. +31 (0)546 536 300  
sales@tecnotion.com

**Tecnotion D-A-CH**

Elsenheimerstraße 59  
80687 Munich  
Germany

Tel. +49 89 381537-400  
Fax +49 89 381537-409  
info@tecnotion.de

**Tecnotion East Europe**

Ul. Ryzowa 49  
02-495 Warsaw  
Poland

Tel. +48 606 544 046  
info@tecnotion.pl

**Tecnotion Rep. of Korea**

Room #909,  
DongJin IT Tower,  
30, Sangwon 12-gil  
Seongdong-gu  
Seoul South Korea

Tel. +82 (0)10 4540 5599  
korea@tecnotion.com

**Tecnotion USA**

200 Broadhollow Rd -  
Suite 207  
Melville, NY, 11747  
United States

Tel. +01 (631) 983-2833  
salesusa@tecnotion.com

**Tecnotion China**

Building 15  
369 Lushan Road  
SND NEP, Suzhou  
China

Tel. +86-512-68760183  
sales@tecnotion.com.cn

